



Shri Shivaji Education Society, Amravati's
SCIENCE COLLEGE

Congress Nagar, Nagpur - 440 012 (M.S.) INDIA

'A+' Grade with 3.51 CGPA in 3rd Cycle

College with Potential for Excellence

Recognised Centre for Higher Learning & Research

Institutional Member of APQN

A Mentor College under UGC PARAMARSH Scheme

An ISO 21001:2018 Certified Institution

NIRF 2024 Rank-band : 201-300



E-mail: shivajiscience_ngp@yahoo.com Web : www.sscnagpur.ac.in



4th Cycle

Assessment & Accreditation by NAAC

CRITERION- I

Metric No.: 1.3.2.1QnM: Number of Students Undertaking Project Work/Field Work/Internships.



Shri Shivaji Education Society, Amravati's
SCIENCE COLLEGE

Congress Nagar, Nagpur- 440 012 (M.S.) INDIA

• Tel : +91-712 - 2423432 (D) • Telebx : +91-712 - 2440555
• E-mail : shivajiscience_ngp@yahoo.com
• Web : www.sschagpur.ac.in

Shri Harshwardhan P. Deshmukh
President

Prof. M. P. Dhore
Principal

- 'A+' Grade with 3.51 CGPA (3rd Cycle) Reassessment College by MAAC, Bangalore
- A College with Potential for Excellence identified by UGC, New Delhi
- Member, APQN (Asia Pacific Quality Network)
- Recognized Centre for Higher Learning & Research
- Mentor College under Paramarsh Scheme UGC, New Delhi



Dr. Panjabrao alias Bhausaheb Deshmukh
Founder President

No. Sc

Date: 03/05/2024

Self-Declaration

This is to certify that, the information, reports, true copies of the supporting documents, numerical data, and weblinks furnished in this file are verified by IQAC and the head of the institution and found correct.

Dr. A. A. Halder
Coordinator, IQAC
Science College,
Congress Nagar, Nagpur

Prof. M. P. Dhore
Principal
Science College,
Congress Nagar, Nagpur



Metric No.: 1.3.2.1QnM: Number of Students Undertaking Project Work/Field Work/Internships.

2023-2024			
Project Work	Field Work	Internship/On-job Training	Total
497	158	130	785

Students Undertaking Project Work, Field Work, Internships

INDEX		
Sr. No.	Details	Page Nos.
1	Project work A. Physics B. Chemistry C. Microbiology D. Computer Science E. Computer Application F. Environmental Studies	5-284
3	Field-Work A. Zoology B. Botany C. Geology	285-362
4.	Internship/ On-Job-Training A. Physics B. Chemistry C. Microbiology D. Zoology E. Botany F. Maths G. CS	363-596

	H-MCA	
--	-------	--



Shri Shivaji Education Society Amravati's
Science College

Congress Nagar, Nagpur
Accredited with CGPA of 3.51 at 'A+' Grade



Department of Physics

Project Title List M.Sc.-II (2023-24)

Sr. No.		Name of the Students	Project Title
1.	Ku	Achal Diwakar Mohurle	Investigation of optical properties of Ni-Cu-Zn ferrites with the substitution of lanthanum
2.	Ku	Premlata Ishwardas Uparikar	Study of influence of calcination temperature on $ni_{0.5}, zn_{0.5}, Fe_2O_4$ synthesis using Hydrothermal Method .
3.	Ku	Purna Ambade	Influence of trivalent incorporation in $cd, cd-La, cd-Dy$ spinel ferrites on structural, magnetic and optical parameter
4.	Mr.	Rahul Khangar	Improvement of energy storage density and energy harvesting performance of amphoteric Pr ion-modified lead-free (BCST) ceramics.
5.	Ku	Riya Faldu	Synthesis of Silver Nanoparticles using Green leaves.
6.	Ku	Sakshi Nale	Comparative study for impact of different synthesis approaches on structural and magnetic properties of Ni-Zn nanostructured ferrites by solving get auto combustion, co-ppt and hydrothermal method.
7.	Ku	Samiksha Bhusari	Structural and Magnetic study of Bi^{3+} incorporated Mg-Zn spinel Ferrite synthesized using Sol-gel approach.

8.	Ku	Vaishnavi Ramesh Khade	Synthesis and characterization of Ni _{0.5} Zn _{0.5} Fe ₂ O ₄ spinal ferrites by using CO-PRECIPITATION approach according to different pH(7,10,12)
9.	Mr.	Vedant Maske	Improvement of energy storage density and energy harvesting performance of amphoteric Pr ion-modified lead-free (BCST) ceramics.
10.	Mr.	Yash Shriprakash Chaube	Investigation of structural properties of Ni-Cu-Zn ferrites with the substitution of lanthanum.



Dr. S. W. Anwane
 Professor and Head
 Department of Physics
 Shi Shriwaj Education Society Anwaraji's
 SCIENCE COLLEGE
 Congress Nagar, Nagpur.

A project report on
**“COMPARATIVE STUDY FOR IMPACT OF DIFFERENT
SYNTHESIS APPROACHES ON STRUCTURAL AND
OPTICAL PROPERTIES OF Ni-Zn NANOSTRUCTURED
FERRITES”**

Submitted to



R.T.M. Nagpur University Nagpur
In the partial fulfillment of the degree of
MASTER OF SCIENCE IN PHYSICS

By

Ms. Sakshi T. Nale
M. Sc. II (Physics)

Guide

Prof. S. W. Anwane
(Head and Professor)

Department of Physics

S. S. E. S. Amt's Science College
Congress Nagar, Nagpur-440012.

Co -Guide

Dr. Ragini Pathare
(Assistant Professor)

Department of Physics

S. S. E. S. Amt's Science College
Congress Nagar, Nagpur-440012.



Department of Physics

S. S. E. S. Amt's Science College, Congress Nagar, Nagpur-440012
2023-2024

CERTIFICATE

This is to certify that Ms. Sakshi T. Nale has carried out project work entitled "COMPARATIVE STUDY FOR IMPACT OF DIFFERENT SYNTHESIS APPROACHES ON STRUCTURAL AND OPTICAL PROPERTIES OF Ni-Zn NANOSTRUCTURED FERRITES" under my supervision in the project program carried out during the academic year 2023-2024 towards partial fulfillment of the requirement prescribed for the Master's Degree of Science (M.Sc. Physics) of Rashtrasant Tukadoji Maharaj Nagpur University, Nagpur, in the faculty of Science and Technology.

Place: Nagpur

Date: 24/05/24



Supervisor

Dr. S.W. Anwane

(Professor & Head)

Department of Physics

S.S.E.S. Amt's Science College

Congress Nagar, Nagpur-440012

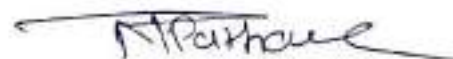

Co-Supervisor

Dr. Ragini Pathare

(Assistant Professor)

Department of Physics

S.S.E.S. Amt's Science of College

Congress Nagar, Nagpur-440012

DECLARATION

I, hereby, declare that the work presented in this Project Report on "COMPARATIVE STUDY FOR IMPACT OF DIFFERENT SYNTHESIS APPROACHES ON STRUCTURAL AND OPTICAL PROPERTIES OF Ni-Zn NANOSTRUCTURED FERRITES" has been carried out by me under the guidance of Dr. S.W. Anwane and Dr. Ragini Pathare, Department of Physics, S.S.E.S Amt's Science College Nagpur, Nagpur.

The work presented in this dissertation, submitted for the award of the degree of Master of Science in Physics to Rashtrasant Tukadoji Maharaj Nagpur University, Nagpur, has not submitted to any other university or institution for the award of a degree or a diploma or certificate.

Place: Nagpur

Date:

Ms. Sakshi T. Nale

Certified by

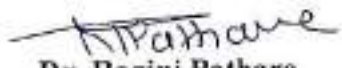
Dr. Ragini Pathare
(Assistant Professor)
Department of Physics
S.S.E.S. Amt's Science College
Congress Nagar, Nagpur-440012

Dr. S W. Anwane
(Professor & Head)
Department of Physics
S.S.E.S. Amt's Science of College
Congress Nagar, Nagpur-440012

ACKNOWLEDGMENT

I would like to thank our honorable Principle, Dr. M. P. Dhore Sir, Shri Shivaji Science College, Nagpur. I wish to give my sincere and special thanks to Prof. S.W. Anwane Sir, Project Supervisor, Head Department of Physics who willingly extended every possible help always. His encouragement was the constant source of inspiration.

I take this opportunity to express my deep sense of gratitude towards my teacher Dr. Ragini Pathare, her interaction, communication and constant encouragement proves to be the yard-stick in successful completion of the project. I am thankful to Dr. J. L. Jadhav, Dr. S. Sayyad, Dr. S. Khangar, Mr. B. T. Kumbhare, Mr. Sarang R. Daf, Ms. K. P. Jivnapurkar and Ms. C. Jatgade for suggesting the problem and supervising the project till its completion and for their cordial support.

I am very thankful to all the teaching and non-teaching staff of Department of Physics during the progress of the project work and helping me throughout.

I convey my sincere regards towards my family, their blessings and guidance always enlightened my path and I would also like to thank my friends for their kind suggestions, support and valuable advice in molding this project into a comprehensive one.

Ms. Sakshi T. Nale
M.Sc. IInd year Physics

CONTENT

SR. NO.	CHAPTER NAME
1.	INTRODUCTION 1.1 Nanoscience 1.2 Nanotechnology 1.3 Nanoparticles 1.4 Nanomaterials 1.5 Magnetism 1.5.1 Diamagnetism 1.5.2 Paramagnetism 1.5.3 Ferromagnetism 1.5.4 Antiferromagnetism 1.5.5 Ferrimagnetism
2.	INTRODUCTION TO FERRITES 2.1 Classification on basis of magnetism 2.1.1 Soft Ferrites 2.1.2 Hard Ferrites 2.2 Classification on the basis of crystal structure 2.1 Spinel Ferrites 2.2 Garnet Ferrites 2.3 Ortho Ferrites 2.4 Hexaferrites 2.3 Uses and application
3.	LITERATURE REVIEW
4.	METHODS AND PROCESS OF SYNTHESIS 4.1 Methods 4.2 Process of synthesis 4.1.1 Co-precipitation Method 4.1.2 Sol-Gel Auto Combustion Method 4.1.3 Hydrothermal Method
5.	CHARACTERIZATION TECHNIQUES 5.1 X-Ray Diffraction 5.2 FTIR 5.3 Raman Spectroscopy

6.	RESULT AND DISCUSSION
7.	CONCLUSION
8.	REFERENCE

CHAPTER 1
INTRODUCTION

1.1 NANOSCIENCE

The term "Nanoscience" itself was coined in the 1970s by Professor Norio Taniguchi. The word "nanoscience" comes from the Greek word "nanos" (or Latin "nanus"), which means "dwarf", and the word "science". Nanoscience is the study of processes and manipulation of the materials at atomic or molecular scale, such that the properties vary considerably than at larger scales i.e., bulk materials. Nanoscience is the study of structures and molecules on the nanometer scale, which is between 1 and 100 nanometers. The way molecules and atoms assemble on the nanoscale into larger structures determines important properties of materials, such as electrical, optical, thermal, and mechanical properties. In nanometer size structures, these properties often differ from those on the macroscale.

Nanoscience is a convergence of physics, materials science and biology, which deal with manipulation of materials at atomic and molecular scales. Nanoscience is the study of phenomena on a nanometer scale. Typically, nano means 10^{-9} . So, a nanometer is one billionth of a meter and is the unit of length that is generally most appropriate for describing the size of single molecule. Anyhow the rough definition of Nanoscience could be anything which has at least one dimension less than 100 nanometer [1].

1.2 NANOTECHNOLOGY

The term nanotechnology comes from the Greek word "nanos" that means "dwarf". Science uses this prefix to indicate 10 or one billionth. One nanometer one billionth meter that is about 100,000 times smaller than the diameter of a single human hair. Nanotechnology is the branch of science and engineering which deals with creation of materials, devices and systems through the manipulation of individual atoms and molecules. The goal of nanotechnology is to control the individual atoms and molecules to create computer chips and other devices that are thousands of times smaller than current technologies limit.

The technology that utilizes nanoscience in practical applications is called nanotechnology. Nanotechnologies include "nanoscale designing, characterizing, and producing structures, devices and systems by controlling shape and size for their applications in various fields". Nanotechnology and Nano science open up new of research and lead to new engines surface allow making products that perform better. The properties of materials differ in fundamental and valuable ways from the properties of individual atoms and molecules or bulk matter.[2]

1.3 NANOPARTICLES

Nanoparticles are tiny particles which have diameter between 1 to 100 nanometers and they found in various products like electronics, medicine and these particles are made from various materials such as metals ceramics or polymers. Nanoparticles have their unique properties due to their size and which makes them useful in different fields. Nanoparticles have special properties that regular particles don't have. Nanoparticles can be synthesized through various methods, such as chemical synthesis, physical vapour deposition, or even by breaking down larger materials into smaller particles. Scientists and engineers are continuously exploring new ways to create and utilize nanoparticles for a wide range of purposes.[3]

1.4 NANOMATERIALS

Nanomaterials are fascinating materials that exists at the nanoscale and which is very small and typically ranging from 1 to 100 nanometers. At this range, material exhibits unique properties. These properties are arises from the high surface area to volume ratio of nanomaterials which is allowing for increased reactivity, strength and other characteristics. The smaller something is the larger its surface area to volume ratio. If a bulk material is sub-divided into an ensemble of individual nano materials, the total volume remains the same, but the collective surface area is greatly increased. It means nano particles have increased surface to volume ratio compared to bulk materials. For example, for a particle of 1 micrometer in diameter, nearly 0.15% of its atoms are on the surface, while for a particle of 6nm in diameter, nearly 20% of its atoms are on surface. The chemical group that are at the material interface determine its properties Like catalytic reactivity, electrical resistivity, adhesion, gas storage and chemical reactivity depend on the nature of interface. Nanomaterials have a significant proportion of atoms at the existing at the surface. Nanoparticles are one of the type of an nanomaterial. These special properties make nanomaterials stand out and valuable for various applications in medicine, electronics and energy sectors. [4]



1.5 MAGNETISM

Magnetism is a force of nature produced by moving electric charges. Sometimes these motions are microscopic and inside of a material known as magnets. Magnets, or the magnetic fields created by moving electric charges, can attract or repel other magnets, and change the motion of other charged particles.[5]

1.5.1 DIAMAGNETISM

Diamagnetic materials are those materials that are freely magnetized when placed in the magnetic field. However, the magnetization is in the direction opposite to that of the magnetic field. The magnetism that is shown by these materials is known as diamagnetism. Diamagnetic materials are substances that are usually repelled by a magnetic field. The permanent magnetic momentum in an atom of the diamagnetic material is zero. Diamagnetic properties arise from realignment of electron path under the influence of an external magnetic field. Diamagnetism is present in all materials and is independent of temperature but the effect is so weak it is often neglected in comparison to paramagnetic and ferromagnetic effects. Diamagnetic materials have a weak, negative susceptibility to magnetic field. Some of the most common examples of diamagnetic substances are Copper, Zinc, Bismuth, Silver, Gold, Antimony, Marble, Water, Glass, etc..[6]

1.5.2 PARAMAGNETISM

Paramagnetic materials are materials that tend to get weakly magnetized in the direction of the magnetizing field when placed in a magnetic field. Paramagnetic materials have a permanent dipole moment or permanent magnetic moment. However, if we remove the applied field the materials tend to lose their magnetism. These materials usually experience a weak attraction to magnets. This type of magnetism is known as paramagnetism. It occurs mainly due to the presence of unpaired electrons in the material or due to the partial alignment of randomly oriented atomic dipole along the field. When the net atomic dipole moment of an atom is not zero, the atoms of paramagnetic substances have permanent dipole moment due to unpaired spin. Magnetic susceptibility is small and positive. Some of the examples of paramagnetic materials include iron oxide, oxygen, titanium, aluminium, transition metal complexes, etc.

CHAPTER 2
INTRODUCTION TO FERRITES

● FERRITES

The term ferrite is derived from a Latin word "ferrum" meaning iron oxides which finds potential applications for making many devices such as permanent magnets, memory storage devices, and for the telecommunication purpose. Ferrites are the magnetic material with ferromagnetic ordering having iron as the principle component of its composition. Iron which is present in the form of iron oxide in nature has pure phases such as Magnetite (Fe_3O_4), Hematite (Fe_2O_3), Iron oxide beta phase; Maghemite etc. these compounds have properties like trivalent oxidation state, distinct color and low solubility. The most important ferrite is magnetite (Fe_3O_4) which contains both Fe^{2+} ion and Fe^{3+} ion. Ferrites are basically the class of magnetic nanoparticles which are the derivatives of magnetite and hematite as well as other oxides of metals. The growing interest in ferrites is due to their spontaneous magnetization. In the absence of the applied magnetic field, high permeability, low magnetic losses, high electrical resistivity, low eddy current losses, good thermal and chemical stability, biological compatibility, relative ease of preparation and number of applications in various fields.[9]

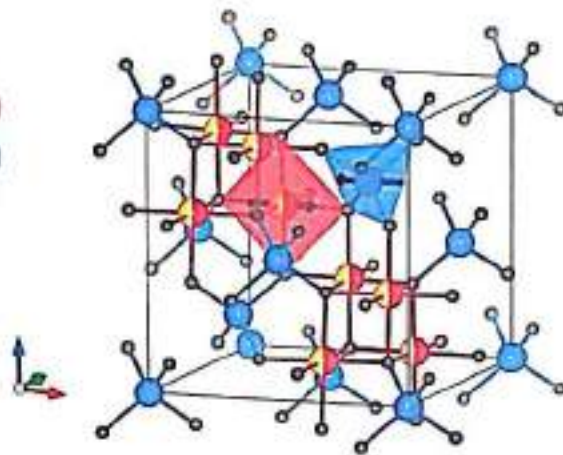

In 1930, Yogoro Kato and Takeshi Takei Spinel Ferrite Nanostructures for Energy Storage Devices reported the first ferrite compound in the Tokyo Institute of Technology. Ferrites can be obtained in three different crystal systems by various synthesis methods, and the flexibility to prepare the unlimited number of solid solutions compositions to tailor their properties for myriad applications.

● NANOFERRITES

Nanoferrites are a type of ferrites that have been engineered at the nanoscale. They have unique properties due to their small size. These nanomaterials have enhanced magnetic properties compared to regular ferrites, making them useful in applications like data storage and high-frequency devices. They can also have other interesting properties like enhanced catalytic activity and biomedical applications. They have many applications in medicine and technology. Nanoferrites can be synthesized at the nanoscale using various methods, such as sol-gel, auto-combustion, co-precipitation, or hydrothermal techniques. These methods allow scientists to precisely control the size, shape, and composition of the nanoferrite particles.

Nanoferrites have been the up-and-coming focus of attention of recent scientific research both from a synthesis and an application perspective. The properties of nanoferrites are very sensitive to the method of preparation and the sintering condition. Therefore, the selection of an appropriate process is the key to obtaining high-quality ferrites.

2.1 Classification on basis of magnetism

Ferrites can be classified according to crystal structure that is, cubic vs. hexagonal ferrite or magnetic behavior; that is, soft vs. hard ferrite. Soft ferrites are easy to magnetize and demagnetize. Hard ferrites are hard to magnetize and demagnetize. Hard magnetic materials are commonly used for permanent magnetic applications.

2.1.1 Soft Ferrites

Soft ferrites have low coercivity, so they easily change their magnetization and act as conductors of magnetic fields. They are typically composed of iron oxide and other metal oxides such as nickel, zinc, or manganese. These ferrites have a high magnetic permeability and low coercivity, which means they are susceptible to demagnetization. This property makes them ideal for use in high-frequency applications such as transformers, inductors, and other electronic components. Soft ferrites are also used in magnetic shielding applications, where they can help to reduce magnetic interference. Soft ferrites are not permanent magnets. They carry magnetism like mild steel but as soon as the magnetic field is removed, the magnetism disappears. Soft ferrites are popular as transformers to change the voltage from primary to secondary windings. So soft ferrites are often called transformer ferrites.[10]

There are several kinds of soft ferrites. Manganese-Zinc ferrites are the most common type of soft ferrites, which are employed to make power, shielding, and linear inductive components. Nickle-Zinc ferrites have outstanding resistivity. Ferrites that are used in transformer or electromagnetic cores contain nickel, zinc, or manganese compounds.[11]

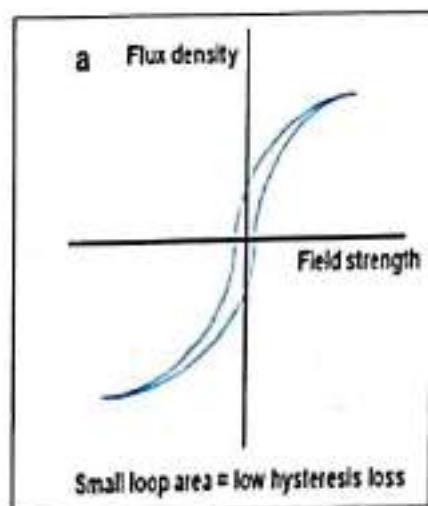

2.1.2 Hard Ferrites

Hard ferrites are also known as permanent magnetic materials because they can hold their magnetism after being magnetized. Hard ferrites are those ferrimagnetic materials which have gradually rising magnetization curve, large hysteresis loop and large energy losses during magnetisation. Hard ferrites can be produced by heating and sudden cooling and cannot be easily magnetized and demagnetized. Hard ferrites are compound of iron and barium or strontium oxides. Hard ferrites have high saturation flux density, low susceptibility and permeability, high eddy current losses, and high retentivity and coercivity. Therefore, hard ferrites are used in permanent magnet, DC magnet, loud speakers, etc. [12].

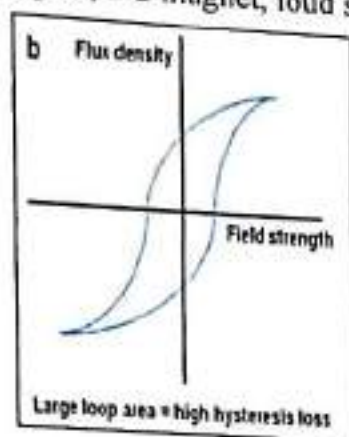

2.2 Classification on basis of crystal structure

In most of the research work done on ferrites, scientists classify the ferrites according to their crystal structure. Hence, there are four important types of ferrites: spinel ferrites, garnet ferrites, ortho ferrites, and hexaferrites.

2.2.1 Spinel Ferrite

The general structural formula of a spinel ferrite can be written as MFe_2O_4 , where M stands for the divalent metal ion like, Fe, Co, Ni, Mn, Mg, Cu and Zn, etc. or a combination of these ions. The spinel structure belongs to space group $Fd\bar{3}m$. The unit cell of spinel ferrite is face-centered cubic (f.c.c) with eight formula units per unit cell ($M_8Fe_{16}O_{32}$). [13] Based on crystal structure, spinel can be categorized into three types, that is, normal spinel, inverse spinel and complex spinel. For normal spinel, M (II) and Fe (III) occupy at tetrahedral and octahedral sites respectively, and $ZnFe_2O_4$ is a typical example of normal spinel. Usually, the interstices of octahedral sites are larger than that of tetrahedral sites, so the cations at smaller radius are inclined to locate at the M sites while the cations at larger radius are inclined to locate at the Fe (III) sites. While for inverse spinel, half of the Fe (III) locates at tetrahedral sites, and the M (II) along with the other half Fe (III) locates at octahedral sites, such as $NiFe_2O_4$. For complex spinel, M (II) and Fe (III) occupy at the tetrahedral and octahedral sites randomly. [14]

2.2.2 Garnet Ferrites

CHAPTER 4
METHODS AND PROCESS OF
SYNTHESIS



fig. Solutions in beakers

ring on magnetic stirrer for 20 minutes. Now solution from second beaker is transferred to
a beaker and kept for heating and stirring for another 20 minutes.



fig. Titration

STEP 2- When the temperature of solution is reached to 80° Celsius, titration using NaOH
solution in burette is started. By titration, we are adding base to acid dropwise, while
maintaining the pH of 12 for the synthesis. After attaining the pH value of 12, the solution is
kept for heating and stirring till its water is evaporated to get precipitation i.e. for almost 2
hours.



fig. Filtration



fig. Crushing



fig. Calcination

4.2.2 SOL-GEL AUTO COMBUSTION METHOD -

Sr. No.	Chemical used	Molecular weight	For 30 ml solution
01.	Zinc Nitrate	237.70 g/mol	2.42180402 gm
02.	Nickel Nitrate	290.80 g/mol	2.9628128 gm
03.	Ferric Nitrate	404.00 g/mol	16.46459948 gm
04.	Urea	60.06 g/mol	8.1507836 gm

Synthesis involves following steps

STEP 1- At first 30 ml of distilled water is taken in a beaker and Zinc nitrate, Nickel nitrate, Ferric nitrate and Urea are added to it to form homogenous solution. This process is known as hydrolysis.



Fig. Hydrolysis

STEP 2- Then the beaker is placed on a magnetic stirrer with a needle in it and stirred for 20 minutes. After stirring, it is kept for heating about 2 hours.

STEP 3- Heating and stirring is continued till gel is formed in the beaker. This method is known as gelation.

STEP 4- Once, the gel formation takes place in a beaker, it is shifted to heater where it is heated till fire or till auto-combustion occur. Auto combustion occur due to presence of urea. Now gel is completely transferred in solid mass.

STEP 5- And the material is ready for grinding for almost 3 hours and then it is placed in the furnace at 800degree Celsius for calcination.

STEP 6- Now the sample is ready for the characterization such as XRD, FTIR and Raman Spectroscopy.



fig. Gel formation



fig. Auto-Combustion



fig. Crushing

4.2.3 HYDROTHERMAL METHOD -

Sr. No.	Chemical used	Molecular weight	For 50 ml of solution
01.	Zinc Chloride	136.30 g/mol	0.6815 gm
02.	Nickel Chloride	237.69 g/mol	1.18845 gm
03.	Ferric Chloride	162.21 g/mol	3.2442 gm
04.	Sodium Hydroxide	40.00 g/mol	8.00 gm

Synthesis involves following steps

STEP 1- At first, 3 beakers are cleaned properly and 50 ml of distilled water is added in each beaker. Now chemicals are weighted with the help of weighing machine as shown in the calculations. After that, Zinc Chloride and Nickel Chloride is added in first beaker, Ferric Chloride is added in second beaker and NaOH is added in the third beaker. After, all these chemicals are added in distilled water, first two beakers and a magnetic needle in it, it is kept for stirring on magnetic stirrer for 20 minutes. Now solution from second beaker is transferred to first beaker and kept for heating and stirring for another 20 minutes.

STEP 2- When the temperature of solution is reached to 80 °Celsius, titration using NaOH solution in burette is started. By titration, we are adding base to acid dropwise, while maintaining the pH of 12 for the synthesis. After attending the pH value of 12, the solution is kept for heating and stirring till its water is evaporated to get precipitation i.e. for almost 2 hours.

STEP 3- Now the solution is transferred to the autoclave and is kept in the oven for next 20 hours.

CHAPTER 6
RESULT AND DISCUSSION

6.1 XRD RESULTS

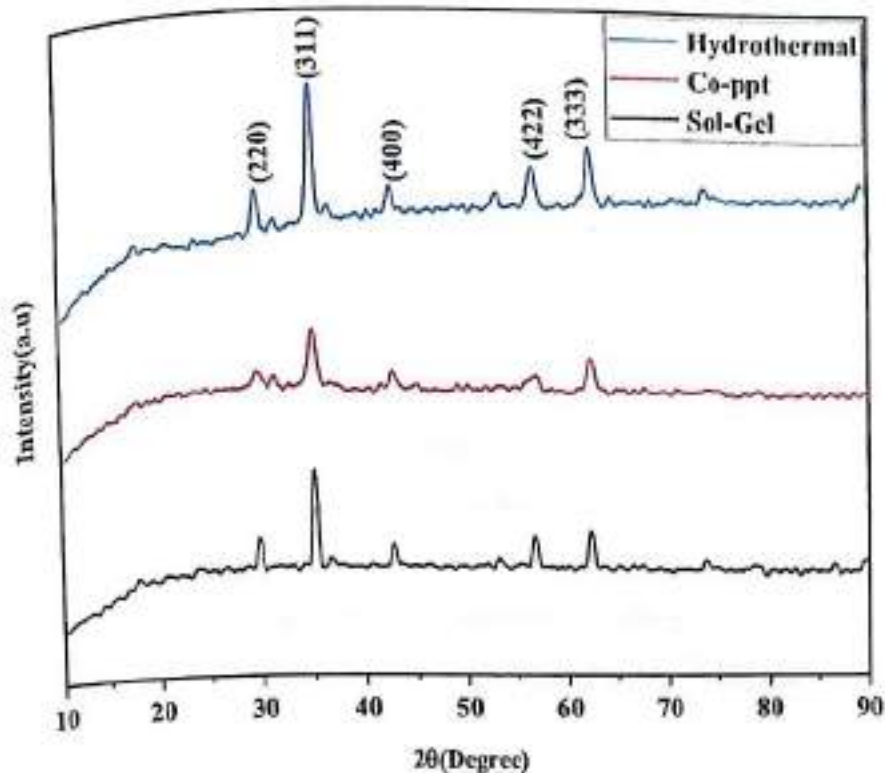

Fig. 6.1.1 XRD RESULT GRAPH

Table 6.1:- Peak position, lattice dimensions, crystalline size, strain, dislocation density, interplanar spacing and X-ray density fraction of $\text{Ni}_{0.5}\text{Zn}_{0.5}\text{Fe}_2\text{O}_4$.

S. No.	Method	2θ (degree)	$a(\text{Å}^\circ)$	$D \times 10^{-9}$ (m)	$\epsilon \times 10^{-3}$	$\delta \times 10^{15}$ lines/m ²	β (deg)	d-spacing (Å°)	$\rho_{x\text{-ray}}$ (g/cm ³)
1.	Sol-gel	35.134	8.4643	25.652	4.47703	1.51969	0.325	2.5521	5.20752
2.	Co-ppt	35.11	8.4699	12.825	8.96058	6.07974	0.65	2.5538	5.19713
3.	Hydrothermal	35.28	8.4305	16.039	7.131662	3.88712	0.52	2.5419	5.27046

- X-ray diffraction of the prepared Nano crystalline sample $\text{Ni}_{0.5}\text{Zn}_{0.5}\text{Fe}_2\text{O}_4$ by Sol-Gel Auto-combustion, Co-precipitation and Hydrothermal method has been studied for the determination of crystallographic structure.
- The intensity of (311) plane is more as compared to other planes like (220), (440), (422) and (333) and is chosen for the determination of crystallite size as per the standard reference data of Joint Committee on Powder Diffraction Standard (JCPDS file No 74-2403) which confirms the formation of spinel ferrite with space group Fd-3m .

6.3 RAMAN SPECTROSCOPY RESULTS

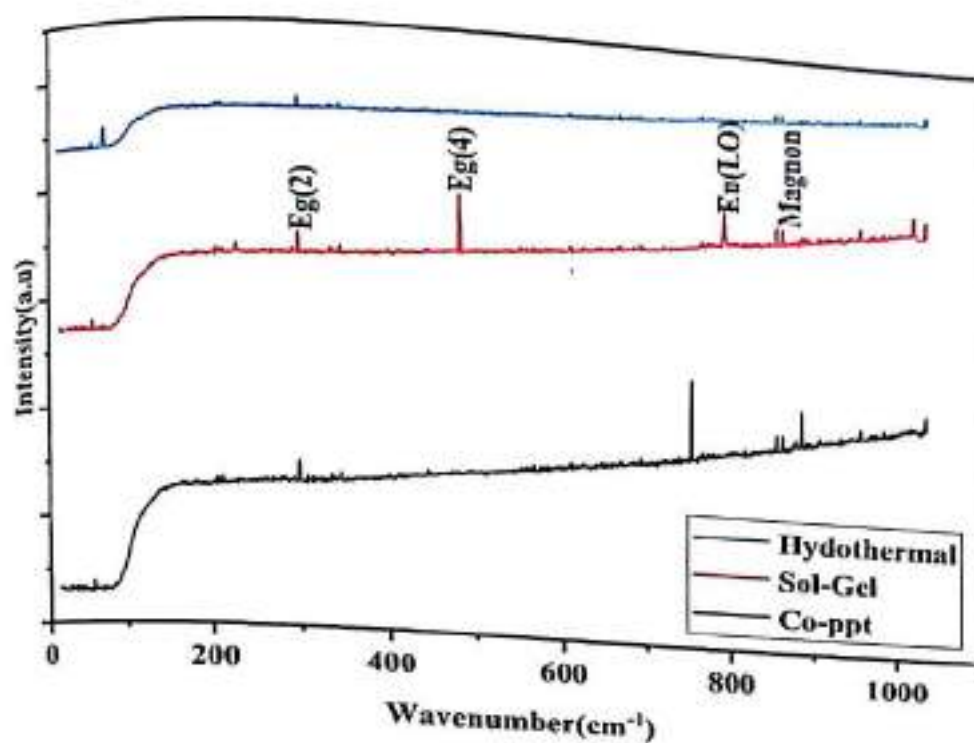

Fig. 6.3.1 RAMAN RESULT GRAPH

- Raman Spectroscopy provides valuable information about molecular vibrations, crystal structures and chemical bonding in the sample.
- Raman spectroscopy is performed at 520nm range for different time in seconds. Samples are characterized at the range of 0-1000 wavelength. After the characterization, we have plot the graph between wavenumber and intensity of the sample.
- Raman modes are decided on the basis of wavenumber (cm^{-1}).
- For Raman mode $E_g(2)$ the wavenumber is $294.08 \pm 0.63 \text{ cm}^{-1}$, for Raman mode $E_g(4)$ the wavenumber is $414.97 \pm 0.14 \text{ cm}^{-1}$, for Raman mode $E_u(LO)$ the wavenumber is $667.03 \pm 0.16 \text{ cm}^{-1}$, for Raman mode Magnon the wavenumber is $826.35 \pm 0.39 \text{ cm}^{-1}$.

CHAPTER 8
REFERENCES

1. <https://www.ncbi.nlm.nih.gov/pmc/articles/>
2. Mansoori, G. Ali, and TA Fauzi Soelalman. *Nanotechnology--An Introduction for the standards community*. ASTM International, 2005.
3. Rao, G. Naga Mallikarjun, and M. R. K. Vakkalagadda. "A review on synthesis, characterization and applications of nanoparticles in polymer nanocomposites." *Materials Today: Proceedings* (2023).
4. Alagarasi, A. "Chapter-Introduction to nanomaterials." *Indian Institute of Technology Madras* (2013): 1-24.
5. Jiang, Xue, et al. "Recent progress on 2D magnets: Fundamental mechanism, structural design and modification." *Applied Physics Reviews* 8.3 (2021).
6. Albagami, Abdullah Mohamed. *An experimental study on the magnetic and exchange bias properties of selected Mn rich Ni-Mn-Ga based Heusler alloys*. MS thesis. Miami University, 2016.
7. <https://infinitylearn.com/surge/blog/nect/ferromagnetic-materials-example-causes-and-properties/>
8. http://uptti.ac.in/classroom-content/data/UNIT_4_LLECTURE_3_AS.pdf
9. Hemingway BS, Thermodynamic properties for bunsenite, NiO, magnetite, Fe₃O₄ and hematite, Fe₂O₃ with comments on selected oxygen buffer reactions. *American Mineralogist*, 75, 781-790 (1990). and Torruella P, Ruiz-Caridad A, Walls M et al., Atomic-Scale Determination of Cation Inversion in Spinel-Based Oxide Nanoparticles. *Nano Lett.* 18, 5854–5861 (2018).
10. Valenzuela, Raul. "Novel applications of ferrites." *Physics Research International* 2012 (2012).
11. Srivastava, Richa, and Bal Chandra Yadav. "Ferrite materials: introduction, synthesis techniques, and applications as sensors." *International Journal of Green Nanotechnology* 4.2 (2012): 141-154.
12. <http://www.aimspress.com/data/article/export-pdf>
13. Soufi, Amal, et al. "Spinel ferrites nanoparticles: Synthesis methods and application in heterogeneous Fenton oxidation of organic pollutants--A review." *Applied surface science advances* 6 (2021): 100145.
14. Qin, Hong, et al. "Spinel ferrites (MFe₂O₄): Synthesis, improvement and catalytic application in environment and energy field." *Advances in Colloid and Interface Science* 294 (2021): 102486.
15. <https://www.vedantu.com/chemistry/ferrite>

16. Pullar, Robert C. "Hexagonal ferrites: A review of the synthesis, properties and applications of hexaferrite ceramics." *Progress in Materials Science* 57.7 (2012): 1191-1334.
17. Thakur, Preeti, et al. "Recent advances on synthesis, characterization and high frequency applications of Ni-Zn ferrite nanoparticles." *Journal of Magnetism and Magnetic Materials* 530 (2021): 167925.
18. Shahane, G. S., et al. "Synthesis and characterization of Ni-Zn ferrite nanoparticles." *Journal of Magnetism and Magnetic Materials* 322.8 (2010): 1015-1019.
19. Ichiyangi, Yuko, Tetsuya Uehashi, and Saori Yamada. "Magnetic properties of Ni-Zn ferrite nanoparticles." *physica status solidi (c)* 1.12 (2004): 3485-3488.
20. Nejati, Kamellia, and Rezvanh Zabihi. "Preparation and magnetic properties of nano size nickel ferrite particles using hydrothermal method." *Chemistry Central Journal* 6 (2012): 1-6.
21. Azadmanjiri, Jalal, et al. "Phase reduction of coated maghemite (γ -Fe₂O₃) nanoparticles under microwave-induced plasma heating for rapid heat treatment." *Journal of Materials Chemistry* 22.2 (2012): 617-625.
22. Gómez, Carlos Andrés Palacio, César Augusto Barrero Meneses, and Juan Antonio Jaén. "Raman, infrared and Mössbauer spectroscopic studies of solid-state synthesized Ni-Zn ferrites." *Journal of Magnetism and Magnetic Materials* 505 (2020): 166710.
23. [https://www.sorocaba.unesp.br/Home/Graduacao/Engenharia de Controle Automacao/steven/introduction-to-nanomaterials-ch.pdf](https://www.sorocaba.unesp.br/Home/Graduacao/Engenharia%20de%20Controle%20Automacao/steven/introduction-to-nanomaterials-ch.pdf)
24. Kandpal, N. D., et al. "Co-precipitation method of synthesis and characterization of iron oxide nanoparticles." (2014).
25. Rane, Ajay Vasudeo, et al. "Methods for synthesis of nanoparticles and fabrication of nanocomposites." *Synthesis of inorganic nanomaterials*. Woodhead publishing, 2018. 121-139.
26. [https://www.researchgate.net/publication/274400086 X-Ray Diffraction Instrumentation and Applications](https://www.researchgate.net/publication/274400086_X-Ray_Diffraction_Instrumentation_and_Applications)
27. www.twi-global.com/technical-knowledge/faqs/x-ray-diffraction
28. Mohamed, Mohamed Azuwa, et al. "Fourier transform infrared (FTIR) spectroscopy." *Membrane characterization*. Elsevier, 2017. 3-29.
29. <https://rtilab.com/techniques/ftir-analysis/>
30. <https://studiousguy.com/raman-spectroscopy-uses/>

P. G. Department of Chemistry Project

List of M.Sc. Semester IV Session (2023-2024)

Sr. No.	Name of students	Project guide	Title
1	AMOL SHALIKRAM DHANKAR	Dr. R.U. Khope	Green Synthesis and Characterization of copper nano particles
2	CHAITANYA CHINTAMAN KOHAPARE	Dr. P.S.Utale	Soil analysis of different regions of Gadchiroli
3	DIPALI NARENDRA DUDHE	Dr. R.U. Khope	Synthesis and Characterization of Fe ₂ O ₃ nanoparticles
4	GULSHAN NILESH GOLHAR	Dr. Y. K. Meshram	Phytochemicals Screening on extract of Custard apple Seed and Jackfruit Seed
5	KANCHAN PRABHA SANTOSH KUMAR SINGH	Dr. R. A. Deshmukh	Synthesis, Characterization and Studies on thiazine, and Pyrazoline based ligand and its metal complexes with antimicrobial activity
6	PRAKARSHA OMPRAKASH KHADSE	Dr. S. J. Kene	A Case Study of Physicochemical Parameters of Lake Water and River in Nagpur
7	SAKSHI SHIVAJI MOHITE	Dr. J. K. Gunjate	Synthesis of g-C ₃ N ₄ by Supramolecular Approach using water as solvent
8	SAKSHI VIJAY KOTHE	Dr. R. D. Urkude	Studies on Physicochemical Properties of Emulsified Concentrate Pesticide and Impact of This Pesticide On CO ₂ Evolution of soil
9	SANA SAGIR KHAN	Dr. S.S.Dhote	Computational Separation of Toxic Metals From Spiked Environmental Samples using Reversed Phase Thin Layer Chromatography
10	SEJAL MAHENDRA BHARNE	Dr. V. R. Kihikar	Exploring the chemical composition of Ores: Evaluating metal content and its impact on industrial development
11	SEJAL SANJAY BULKUNDE	Dr. P. N. Deshmukh	Novel Schiff base synthesis its characterization, Metal complex and antimicrobial activity
12	TULIKA TAPASH BANERJEE	Dr. P.S.Utale	Soil analysis of different regions of Ramtek(Nagpur)

13	VAISHNAVI CHANDRAKUMAR CHUTE	Dr. P. N. Deshmukh	Novel metal complex with schieff base and its antimicrobial activity
14	VASUKI SURESH DABHANE	Dr. S. J. Kene	A Case Study of Physicochemical Parameters of Groundwater in Nagpur
15	VISHAKHA SANJAY MISAL	Dr. R. D. Urkude	Studies on Physicochemical Properties of Propoxur 20% EC and on CO ₂ evolution from soil

 Head
 Department of Chemistry,
 Shri Shivaji Science College
 Congress Nagar, Nagpur.

A Project Report On

**“STUDIES ON PHYSICO-CHEMICAL PROPERTIES OF
EMULSIFIED CONCENTRATE PESTICIDE AND IMPACT
OF THIS PESTICIDE ON CO₂ EVOLUTION OF SOIL”**

SUBMITTED TO

• Rashtrasant Tukdoji Maharaj, NAGPUR UNIVERSITY.

FOR THE PARTIAL FULFILMENT OF DEGREE OF MASTER OF SCIENCE
IN ORGANIC CHEMISTRY

BY

SAKSHI VIJAY KOTHE

UNDER THE SUPERVISION OF

DR. RASHMI URKUDE

Professor

(DEPARTMENT OF CHEMISTRY)



Shri. Shivaji Education Society Amravati's Science College,

Congress Nagar, Nagpur

**(AFFILIATED TO RASHTRASANT TUKDOJI MAHARAJ
UNIVERSITY NAGPUR)**

2023-2024

CERTIFICATE

This is to certify that the work incorporated in the project report entitled "STUDIES ON PHYSICO-CHEMICAL PROPERTIES OF EMULSIFIED CONCENTRATE PESTICIDE AND IMPACT OF THIS PESTICIDE ON CO₂ EVOLUTION OF SOIL" submitted by **SAKSHI VIJAY KOTHE** for the partial fulfilment of practical course for the degree of Master of Science in Organic Chemistry. The project was carried out in excellent manner under my supervision in Department of Chemistry Shri. Shivaji Science College Nagpur-440012.

Date: - 9/05/24

Place: - Nagpur



Dr. R. U. Khope

Head and Professor

Department of Chemistry

Shri. Shivaji Education Society

Amravati's Science College,

Congress Nagar, Nagpur

Professor & Head
Department of Chemistry,
Shri Shivaji Science College
Congress Nagar, Nagpur

CERTIFICATE

This is to certify that the work incorporated in the project report entitled "STUDIES ON PHYSICO-CHEMICAL PROPERTIES OF EMULSIFIED CONCENTRATE PESTICIDE AND IMPACT OF THIS PESTICIDE ON CO₂ EVOLUTION OF SOIL" submitted by **SAKSHI VIJAY KOTHE** for the partial fulfilment of practical course for the degree of Master of Science in Organic Chemistry. The project was carried out in excellent manner under my supervision in Department of Chemistry Shri. Shivaji Science College Nagpur-440012.

Date: - 8/05/24

Place: -Nagpur

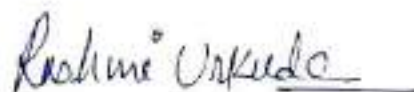

Dr. Rashmi Urkude

Professor

Department of Chemistry

Shri. Shivaji Education Society

Amravati's Science College,

Congress Nagar, Nagpur

Dr. Rashmi Urkude

Professor

Department of Chemistry

SES Am's Science College

Congress Nagar, Nagpur-440012

DECLARATION

The work presented in this project entitled "STUDIES ON PHYSICO-CHEMICAL PROPERTIES OF EMULSIFIED CONCENTRATE PESTICIDE AND IMPACT OF THIS PESTICIDE ON CO₂ EVOLUTION OF SOIL" conducted by me under the guidance of **Dr. Rashmi Urkude**, Associate Professor, **Shri Shivaji Science College, Congress Nagar, Nagpur**. This work has not been submitted earlier to any University or an Institution for the award of any Diploma or Degree.

Date: - 9/5/24

Place: - Nagpur



SAKSHI VIJAY KOTHE

M.Sc. – 2nd year

(Semester-IV)

Check
OK Desh
17/5/24

ACKNOWLEDGEMENT

I express my sincere gratitude to my advisor Dr. Rashmi Urkude for her valuable guidance, constant encouragement, priceless suggestions, indispensable support and sharing her rich experience during the entire course. I am obliged to her for the confidence, she has shown in me and for the patience she has exercised during the entire course of work.

My warmest regards to all faculty members for their direct or indirect support during my course of work in M.Sc. I am also thankful to Dr R.U. Khope, Head and Professor, Department of Chemistry.

I am really indebted for taking interest I completion of this project. A special thanks to PG Co-Ordinator Dr. Mrs. Shubhangi. J. Kene & Ms. Megha Tabhane. I am thankful to my friends and I would like to extent my sincere esteems to lab assistant Mr. Sanjay. Hedau and all the non- teaching staff in laboratory for their support.

Finally, I am thankful to my family members for their love and constant support extended to me. I am Grateful to my parents for bringing me to this stage of life.

Date: - 9/5/24.

Place: - Nagpur
KOTHE



SAKSHI VIJAY

M.Sc. 2nd year
(Semester-IV)

Index

Sr. No	Title	Page No.
1	Introduction	8-12
2	Review of Literature	13-15
3	Materials and Methods	16-22
4	Observation	23-29
5	Results	30-35
6	Discussion	36
7	Conclusion	37
8	Future Plan	38
9	Appendices	39-53
10	References	54-56

ABBREVIATIONS

1) et al.	et alia (and association)
2) conc.	Concentration
3) i.e.	that is
4) %	Percent
5) Gm	Gram
6) Ppm	Part per million
7) min.	Minute
8) hr.	Hour
9) ml.	Millimetre
10) WHO	World Health Organization
11) BIS	Bureau of Indian Standard
12) EC	Emulsified Concentrates
13) ULV	Ultraviolet low volume
14) LC	Liquid Concentrates

INTRODUCTION

A pesticide which is an organic emulsified concentrate compound having pesticidal property which is introduced in market as "Transportex" as trade name and having IUPAC name "2-[(Propan-2-yl)oxy] phenyl methylcarbamate. Common name of this pesticide is Propoxur which is a substance or mixture of substance intended for preventing, destroying, repelling or mitigating any pest.

1.1 Effects of Pesticide on Environment and Public Health: -

Pesticides have significant environmental and public health impacts, spanning from biodiversity loss to acute and chronic health effects. When a pesticide is used in the environment, it becomes distributed among four major compartments: water, soil, air and living organisms. The fraction of the chemical will move into each compartment is governed by the physicochemical properties of that chemical. An example is BCF (bio concentration factor), which is a measure of amount of pesticide that will accumulate in aquatic organisms.^[1]

There are many classes of synthetic pesticides. These pesticides are classified in different major classes as follows:

1. Organochlorines: -

Organochlorides are a group of chlorinated compounds widely used as pesticides. These chemicals belong to the class persistent organic pollutant (POPs) with high persistence in the environment. Organochloride insecticides were earlier successfully used in control of malaria and typhus, yet they are banned in most of the advanced countries (Aktar et al., 2002)^[3]

The review statistics on the use of different pesticides shows that 40% of the all pesticides used belong to the organochlorine class of chemicals (Gupta, 2004; FAQ, 2005)^[4]

Examples: DDT, Aldrin, Dieldrin.

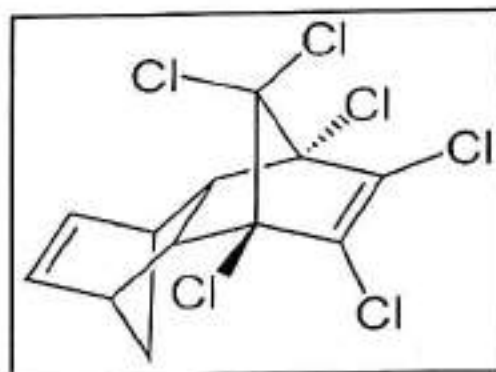

Structure of Aldrin

2. Organophosphates: -

A phosphorus rich organic compound that contains a halide which phosphorylates cholinesterase and irreversibly inhibits its activity management atropine, pralidoxime. These pesticides affect the nervous system by disrupting the enzyme that regulates acetylcholine, a neurotransmitter. Some of them are very poisonous.^[5]

Examples: - Diazinon glyphosate, Malathion, Traizophos.

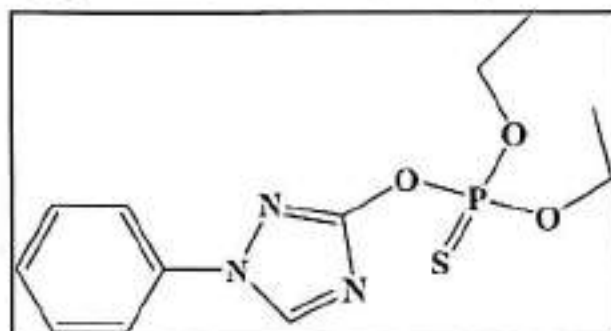

Structure of Traizophos

3. Carbamate: -

Carbamate is an organic compound derived from carbamic acid (NH₂COOH). A carbamate group, carbamate ester and carbonic acid are functional group inter related structurally and often are inter converted chemically. Pesticides affect the nervous system by disrupting an enzyme that regulates acetylcholine, a neurotransmitter^[5].

Sign of toxicity were generally observed when acetylcholinesterase activity was inhibited by more than 70%.^[6]

Examples: - Carbofuran, Propoxur.

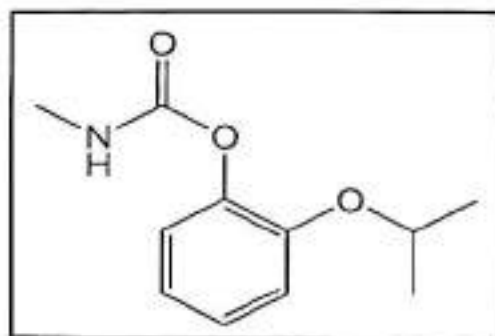

Structure of Propoxur

4. Pyrethroid: -

A Pyrethroid is an organic compound similar to natural pyrethrins produced by the flower of pyrethrums. These pesticides were developed as a synthetic version of the

naturally occurring pesticides. Pyrethroids constitute the majority of commercial household insecticides in the concentration used in such products, they may also have insect repellent properties and are generally harmless to human.^[7]

Examples: Fen valerate, Alphamethrin, Lambda cyhalothrin.

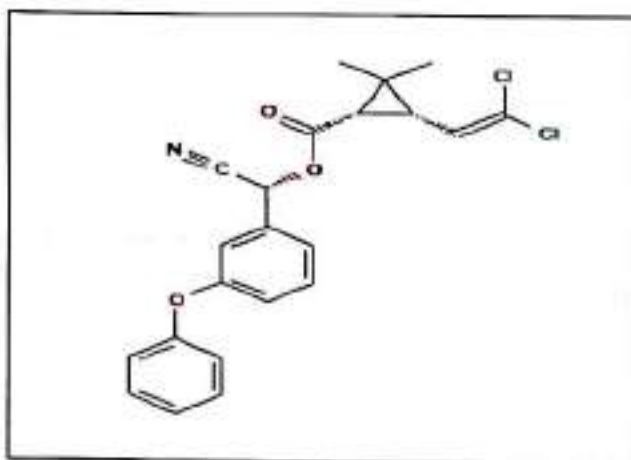

Structure of Alphamethrin

BIS (Bureau of Indian Standards) is the national standard body of India working under the aegis of ministry of consumer affairs, food and public distribution government of India. It is established by the Bureau of Indian Standards act 1986, which came into effect on 23 December 1986 as BIS Act 1963. Three samples from different manufacturers were subjected to carry different physico-chemical properties as per the BIS specifications with the followings objectives to known quality of Indian Standards) is the national standard body of India working under the aegis of ministry of consumer affairs, food and public distribution government of India. It is established by the Bureau of Indian Standards act 1986, which came into effect on 23 December 1986 as BIS Act 1963.^[13]

IMPACT OF PESTICIDE ON CO₂ EVOLUTION FROM SOIL: -

REVIEW OF LITERATURE

Propoxur is an insecticide registered for many years in numerous countries world- wide. Propoxur is an N-methyl carbamate insecticide which is fairly soluble in water, very soluble in polar solvent. It is hydrolysed very slowly at pH 4, slowly at pH 7 but rather rapidly at pH 9.^[22]

Propoxur is of moderate mammalian toxicity, it is rapidly metabolized and does not accumulate in tissues. It is not sensitizing or irritant to skin and is not irritant to the eye, although transient severe miosis occurred following application to the eye. There is no evidence that propoxur is carcinogenic, teratogenic or embryotoxic (post- implantation loss occurred only at doses above the level at which maternal toxicity occurred). In a 5-day study on rats, comparing the toxicity of technical (purity 98.6%) and recrystallized (purity 99.2%) propoxur, no difference in toxicity was found. The JMPR has recommended an ADI of 0.02 mg/kg bw/day for propoxur.^[19]

❖ Propoxur

- IUPAC Name: - 2-[(Propan-2-yl) oxy] phenyl methylcarbamate
- Chemical formula: - $C_{11}H_{15}NO_3$
- Molar mass: - 209.245 g/mol
- Appearance: - White to tan crystalline powder
- Melting point: - 86 to 92 °C
- Vapor pressure: - 0.0000937 mmHg

STRUCTURE:

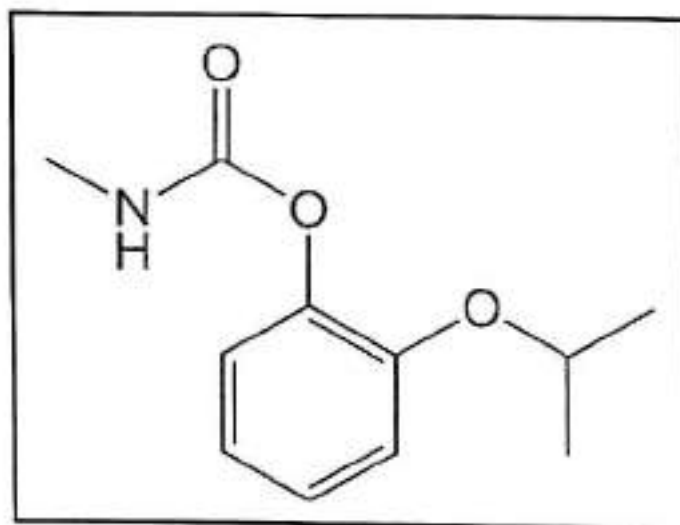

The proposer stated that the data provided for this evaluation were similar to those provided to the JMPR for the evaluation but was unable to state categorically that they were similar to those submitted to the USEPA.^[22]

Propoxur is highly toxic to honeybees, aquatic invertebrates and birds, though its toxicity varies according to the species. It is moderately to slightly toxic to fish. The reported 96-hour LC50 values are 3.7 mg/L in rainbow trout, and 6.6 mg/L in bluegill sunfish. Propoxur is highly toxic to freshwater invertebrates and very highly or highly toxic to birds, its toxicity varying according to species. Propoxur is rather persistent and mobile in soils, having characteristics which could produce leaching to groundwater.^[23]

The Meeting was provided with confidential information on the current manufacturing process, together with data from 5-batch analyses and the manufacturing specifications for all impurities 21 g/kg. Mass balances were high (99.9-100.1%) and no unidentified impurities were present. The current (2000-on) manufacturing process produces a higher purity TC than previously and no new impurities are found (Riegner 2005).^[21]

The manufacturer initially proposed a clause to control the crystal per ratio of propoxur TC, on the basis that crystal modification II has an adverse effect on the suspensibility of water dispersible formulations (Grohs 2004a). The two forms can apparently be distinguished by IR or x-ray diffraction methods but it was subsequently stated that the problem occurs only in WPs formulated with high concentrations (above 50%) of propoxur, which are no longer marketed (Grohs 2004b). The clause is not required for the low concentration and liquid formulations currently marketed and therefore the proposal was withdrawn.^[20]

A proposed clause for melting point of the TC, with a range of 87.5-90°C (instead) of 86-91.5°C in the existing FAO and WHO specifications) was not in accordance with current guidelines in the manual.^[21]

MATERIAL AND METHOD

According to BIS specification the samples were tested for important Physico-Chemical tests like cold test, flash point, emulsion stability and chemical test like various samples from different manufacturers of Nagpur region were subjected to study the Physico-Chemical properties.

PHYSICAL TESTS: - Three Collected samples of Propoxur 20% EC were subjected to carry various physical tests as follows.

COLD TEST: -

Materials: Propoxur 20% EC, cork, conical flask, thermometer, ice cold water, stirrer.

Method: 50ml sample was taken in clean transparent container and closed it with cork fitted with thermometer. The sample was cooled to 10°C by placing the container in ice cold water. The sample was stirred at short interval for 1 hour examined the material for any turbidity or separated solid or oily matter or both. ^[13]

Significance: - Liquid formulation [capsule suspension emulsifiable concentrate] oil in water emulsion micro emulsion soluble concentrate suspension concentrate may be adversely affected by storage at low temperature may be result in crystallization of active constituents' significant changes in viscosity or phase separation of emulsion. In some places night temperature reaches to 0°C or lower. Therefore, the liquid formulations should also be tested at $0\pm 2^{\circ}\text{C}$ or lower for 7 days. The effect of low temperature on stability must be determine and reported according to CIPAC (Collaborative International Pesticide Analytical Council).



Fig No.1: Cold Test

FLASH POINT:

Materials: Propoxur 20% EC, Thermometer Abel's apparatus.

Method: Using Abel apparatus, samples were tested for their flash point. In the method of sample under test was placed in the cup of the Abel apparatus and heated at a prescribed rate. A small test flame is directed into the cup at regular intervals, and the flash point was noted as the lowest temperature at which application of test flame causes the vapours above the sample to ignite with a distinct flash inside the cup^[14]

Specification of sample:

The flash point of the sample should be above 39°C^[16]

ABEL CLOSED CUP APPARATUS: -

Instrumentation:

Abel flash point apparatus with oil test jet device. Electric heated with Energy regulator control. Abel's flash point apparatus with oil test jet, heated by hot plate with Digital Temperature indicator. This apparatus is suitable for determining the close cup flash point of petroleum and mixtures. It is suitable for oils whose flashes below 70°C. It is supplied with oil cup, cover fitted with stirrer, thermometer socket, water bath & stand. An electric heater is fitted at Bottom for operation on 220 Volts AC Circuits.^[15] (Fig: Abel's closed cup point apparatus).

Significance:

The human hazard signal words CAUTION, WARNING and DANGER are not used with flammability statements in order to prevent any confusion e.g. If the product is a total release a fogger containing a propellant with a flash point or below 20° F, the following label statement must be included in the "Physical and Chemical Hazard" section. This product contains a highly flammable ingredient. It may cause a fire or explosion if not used properly.^[15]



Fig No.2: Abel's Instrument

EMULSION STABILITY:

Material: Propoxur 20% EC, standard hard water beaker, measuring flask, volumetric flask.



Method: 2ml sample was taken in clean, transparent beaker. Standard hard water (0.304g of calcium chloride anhydrous and 0.139g of magnesium chloride hexa hydrate was dissolved in distilled water made up to 1 Liter) poured at 30° c to sample at the rate of 15 to 20 ml/min. During addition, the contents of the beaker were stirred continuously with the glass rod and when the volume of diluted emulsion in the beaker reached 100ml then addition of standard hard water was stopped. The diluted emulsion was immediately transferred to clean and dry graduated cylinder. The cylinder was kept with the content for 1hr. at 30° c. ^[13]

After 1 hr. the volume of the creamed matter at the top and sediment at the bottom, if any was noted.

Significance: -

For products which form emulsion, stability is required to determine whether the product forms and maintain a stable emulsion.



Fig No.3 Emulsion stability

Reading after 10 days,

The vials were taken out of each critical flask (incubation chamber) after 10 days from the commencement of the experiment. The contents of the vials were titrated with 0.5N HCl using phenolphthalein indicator (and point colorless). The ml of CO_2 evolved from the soil was determined after considering a blank reading of 10 ml 0.5N NaOH on titration with 0.5 N HCl, and then, calculating the following formulae,

$$\text{CO}_2 \text{ evolved (mg/g soil)} = (B-A) \times 2.2/0.1 \times 10/50$$

Where,

A = ml of 0.5N HCl required to neutralize NaOH in the vial from incubation chamber,

B = ml of 0.5N HCl required for blank reading,

N = Normality of acid used [(1 ml of 0.1N HCl is equivalent to 2.2 mg of CO_2)]

The same procedure was repeated for taking readings of CO_2 that evolved after 0 days, 10 days, 20 days, 30 days, & 40 days and from the readings, we calculated the CO_2 that evolved. The calculated quantity of CO_2 per gram soil from observations for the incubation period of 0 days, 10 days, 20 days, 30 days, & 40 days were considered together and used for comparison. The data collected of the evolved CO_2 , as against various fertilisation levels of PICOZOLIN 20% EC, for different incubation periods derived from the three replications (table no. 1-5) was used.



OBSERVATION

OBSERVATION FOR ACIDITY: -

1. Preparation of 0.1 N Oxalic Acid: Weighed 0.6303 g of oxalic acid in 100 ml volumetric flask.

2. Preparation of 0.1 N NaOH Solution: Weighed 0.4g of NaOH in 100ml volumetric flask.

Standardization of NaOH: -

Sr.No.	Volume of Oxalic Acid (0.1N)	Volume of NaOH (0.1N)	Constant Reading
1	10ml	9.5ml	9.6ml
2	10ml	9.6ml	
3	10ml	9.6ml	

$$N_1V_1 = N_2V_2$$

$$0.1 \times 10 \text{ ml } N_2 \times 9.6$$

$$N_2 = 0.1 \times 10 \div 9.6$$

$$N_2 = 0.10416 \text{ gm/l}$$

N_1 = Normality of NaOH

N_2 = Normality of NaOH

V_1 = Volume of oxalic acid

V_2 = Volume of NaOH

$$\text{Acidity percent by Mass} = \frac{4.9 \times (1.2 - 0.3) \times 0.10416}{10}$$

$$= 0.04593 \%$$

OBSERVATION OF COLD TEST FOR SAMPLE 1,2 AND 3: -

Sample	Observation
1	No turbidity or separation of solid was observed.
2	No turbidity or separation of solid was observed.
3	No turbidity or separation of solid was observed.

OBSERVATION OF EMULSION STABILITY: -

Sample	Observation
1	Creamy layer was not observed
2	Creamy layer was not observed
3	Creamy layer was not observed

OBSERVATION OF FLASH POINT: -

Sample	Observation
1	43 ⁰ c
2	44 ⁰ c
3	45 ⁰ c

RESULTS

RESULTS OF PHYSICOCHEMICAL PROPERTIES: -

A) Results of the various physical and chemical tests performed on different sample of Propoxur 20% EC in collected were as follows: -

SAMPLE: - 1

SAMPLE	TEST PERFORMED	RESULT	STANDARD OBSERVATION
1	Cold test	No turbidity	No turbidity or separation of solid.
2	Emulsion Stability	Creamy layer was not observed	Any separation including creaming at top and sedimentation at bottom shall not exceed 2.0 ml.
3	Flash Point	43 ^o C	Shall be above 39 ^o C
4	Acidity	0.04083%	Shall be not more than 0.3% by mass

SAMPLE: - 2

SAMPLE	TEST PERFORMED	RESULT	STANDARD OBSERVATION
1	Cold test	No turbidity	No turbidity or separation of solid.
2	Emulsion Stability	Creamy layer was	Any separation

		not observed	including creaming at top and sedimentation at bottom shall not exceed
3	Flash Point	45 ^o c	Shall be above 39 ^o c
4	Acidity	0.03572%	Shall be not more than 0.3% by mass

SAMPLE: - 3

SAMPLE	TEST PERFORMED	RESULT	STANDARD OBSERVATION
1	Cold Test	No Turbidity	No turbidity or separation of solid.
2	Emulsion Stability	Creamy layer was not observed	Any separation including creaming at top and sedimentation at bottom shall not exceed 2.0 ml.
3	Flash Point	45 ^o c	Shall be above 39 ^o C
4	Acidity	0.04593%	Shall be not more than 0.3% by mass

IMPACT OF PESTICIDES ON CO₂ EVOLUTION ON SOIL: -

APPENDICES

SAMPLE FOR
0 days system: -

Level of Fortification (ppm)	CO ₂ evolved in mg/soil											
	RI ₁	RI ₂	RI ₃	RI	RII ₁	RII ₂	RII ₃	RII	RIII ₁	RIII ₂	RIII ₃	RIII
0	10.1	10	10	10	10.2	10.1	10.1	10.1	10	10.1	10.1	10.1
5	9.2	9.3	9.3	9.3	9.5	9.4	9.4	9.4	9.5	9.4	9.4	9.4
20	8.3	8.4	8.4	8.4	8.8	8.7	8.7	8.7	9	8.9	8.9	8.9
50	7.5	7.6	7.6	7.6	7.6	7.7	7.7	7.7	7.5	7.7	7.7	7.7
100	6.1	6.2	6.2	6.2	6.4	6.5	6.5	6.5	6.2	6.3	6.3	6.3

$$\text{Std. deviation} = \sigma = \sqrt{\frac{\sum |x_i - \bar{x}|^2}{n-1}}$$

Where, x_i = each reading of CO₂ evolved

\bar{x} = Mean of x_i

n = No. of readings taken

For 0 ppm:

$$\bar{x} = RI + RII + RIII = 10.0$$

Now we find $\sum |x_i - \bar{x}|^2$

- i. $|RI - \bar{x}|^2 = |10.0 - 10.0|^2 = 0$
- ii. $|RII - \bar{x}|^2 = |10.1 - 10.0|^2 = 0.01$
- iii. $|RIII - \bar{x}|^2 = |10.1 - 10.0|^2 = 0.01$

$$\text{Hence, } \sum |x_i - \bar{x}|^2 = 0.02$$

$$\text{Std. deviation} = \sigma = \sqrt{\frac{0.02}{3-1}} = 0.1$$

For 5 ppm: -

$$\bar{x} = RI + RII + RIII = 9.4$$

Now we find $\sum |xi - \bar{x}|^2$

- i. $|RI - \bar{x}|^2 = |9.3 - 9.4|^2 = 0.01$
- ii. $|RII - \bar{x}|^2 = |9.4 - 9.4|^2 = 0$
- iii. $|RIII - \bar{x}|^2 = |9.4 - 9.4|^2 = 0$

$$\text{Hence, } \sum |xi - \bar{x}|^2 = 0.01$$

$$\text{Std. deviation} = \sigma = \sqrt{\frac{0.01}{3-1}} = 0.0707$$

For 20 ppm:

$$\bar{x} = RI + RII + RIII = 8.6$$

Now we find $\sum |xi - \bar{x}|^2$

- i. $|RI - \bar{x}|^2 = |8.4 - 8.6|^2 = 0.04$
- ii. $|RII - \bar{x}|^2 = |8.7 - 8.6|^2 = 0.01$
- iii. $|RIII - \bar{x}|^2 = |8.9 - 8.6|^2 = 0.09$

$$\text{Hence, } \sum |xi - \bar{x}|^2 = 0.14$$

$$\text{Std. deviation} = \sigma = \sqrt{\frac{0.14}{3-1}} = 0.265$$

For 50 ppm:

$$\bar{x} = RI + RII + RIII = 7.7$$

Now we find $\sum |xi - \bar{x}|^2$

- i. $|RI - \bar{x}|^2 = |7.6 - 7.7|^2 = 0.01$

$$\text{ii. } |RII - \bar{x}|^2 = |7.7 - 7.7|^2 = 0$$

$$\text{iii. } |RIII - \bar{x}|^2 = |7.7 - 7.7|^2 = 0$$

$$\text{Hence, } \sum |xi - \bar{x}|^2 = 0.01$$

$$\text{Std. deviation} = \sigma = \sqrt{\frac{0.01}{3-1}} = 0.0707$$

For 100 ppm:

$$\bar{x} = RI + RII + RIII = 6.3$$

Now we find $\sum |xi - \bar{x}|^2$

$$\text{i. } |RI - \bar{x}|^2 = |6.2 - 6.3|^2 = 0.01$$

$$\text{ii. } |RII - \bar{x}|^2 = |6.5 - 6.3|^2 = 0.04$$

$$\text{iii. } |RIII - \bar{x}|^2 = |6.3 - 6.3|^2 = 0$$

$$\text{Hence, } \sum |xi - \bar{x}|^2 = 0.05$$

$$\text{Std. deviation} = \sqrt{\frac{0.5}{3-1}} = 0.500$$

10 Days System:

Level of Fortification(ppm)	CO ₂ evolved in mg/soil											
	RI ₁	RI ₂	RI ₃	RI	RII ₁	RII ₂	RII ₃	RII	RIII ₁	RIII ₂	RIII ₃	RIII
0	8.7	8.8	8.8	8.8	9	8.9	8.9	8.9	8.8	8.9	8.9	8.9
5	7.5	7.6	7.6	7.6	7.7	7.8	7.8	7.8	7.9	8	8	8
20	7.8	7.7	7.7	7.7	7.6	7.8	7.8	7.8	7.9	7.8	7.8	7.8
50	6.4	6.5	6.5	6.5	6.9	6.8	6.8	6.8	7.1	7	7	7
100	6.7	6.6	6.6	6.6	6.3	6.5	6.5	6.5	6.4	6.5	6.5	6.5

References

- 1) Meena R P, Meena S S and Meena S R . Use of Agrochemicals in Agriculture , their consequences and possible solution. 2008, Green farming 1 (4) : 54-55
- 2) Elvis .D. Miensah, Joseph.R.Fianko, Sam Adu-Kumi, WHO Recommended classification of pesticides by Hazards, WHO, Geneva, Journal of environmental protection Vol.6.(1994-95)
- 3) Aktar MW, SenGupta D, Chowdhury A. Impact of pesticides use in Agriculture: their benefits and hazards. Interdisciplinary Toxicology . (2009); 2: 1-12
- 4) Gupta PK. Pesticide exposure-Indian scene. Toxicology. Vol.2.(2014); [PubMed] 198:83-90.
- 5) Renzi, B.E., P.I.Krieger .Sub lethal acute toxicity of carbosulfan [2, 3-dihydro-2, 2-dimethyl 1-7- benzofuranyl (di-n- butylaminosulfanyl) methyl carbamate] in rat after intravenous and oral exposure. Fundam. Appl. Toxicol. (2008), 6,07-15
- 6) Metcalf, Robert L. "Insect Control". Ullmann's Encyclopedia of Industrial Chemistry,(2000). doi:10.1002/14356007.a14_263. ISBN 3527306730.)
- 7) Haddi, Khalid; Berger, Madeleine; Bielza, Pablo; Cifuentes, Dina; Field, Linda M; Gorman, Kevin; Rapisarda, Carmelo; Williamson, Martin S; Bass, Chris. "Identification of mutations associated with pyrethroid resistance in the voltage-gated sodium channel of the tomato leaf miner (*Tuta absoluta*)". Insect Biochemistry and Molecular Biology, (2012). 42 (7): 506-13.)
- 8) Garbach. S-Their W Hoechst AG: GBC- Anatitichesches Laboratorium, (1927). Reportµ .M. 037400-012.
- 10)P. Perucci, S.Dumontet, S.A.Bufo, A.Mazzatura and C.Casucci. Biol. Fertile, soils 32,(2000),17-23.
- 11)Dr. Rashmi Urkude, Dr. Lata Deshmukh, Studies on the impact of pesticides on soil microbial respiration,Correspon International jornal of plant, animals and environmental science.Vol4(10), (2014):1271-77
- 12)Lobe J sep. WHO urges. Inter Press service ci+cel from common dreams Retrieved on september (2007):29-38
- 13) Bureau of Indian standard , Methods of Test For Pesticides and their Formulations (IS: 6940-(1982)
- 14)Bureau of Indian standard, Plain Copier Paper(IS 14590 [P:8] :1997).
- 15)Tracey.D.Bellamy,Richard S. Kraus,NFPA 30: Flammable And Combustnible Liquid code, (2012) Edition:12-25

- 16) Muhammad M.U., Abubakar L, Bagna E. A., Nutritional profile and Phytochemical Composition of Gardenia Sokotensis, African Journal of Food Science and Technology. Vol8. (2017):108-112.
- 17) Mrs. Manisha Jail¹, Dr. Rashmi Urkude² and Dr. Lata Deshmukh³ EFFECT OF INSECTICIDES ON SOIL MICROBIAL RESPIRATION. Correspon International jornal of plant, animals and environmental science. (2016).
- 18) Mrs. Sonika R. Kochhar¹, Dr. Rashmi Urkude .Studies on Physico-Chemical Properties of Commercially Available EC Formulations of Deltamethrin and Profenofos pesticides. International Journal of Researches in Biosciences, Agriculture & Technology (2014):100-104
- 19) JMPR 1989 : Evaluation of pesticides residues in food – 1989 (Part II, Toxixology) . FAO Plant Production and Protection Paper 100/2, FAO, Rome, (1990):100-102
- 20) Sethi S.P. Comparision of manufacturing process information, Specifications and Batch analyses for Propoxur active constituent submitted to WHO with the information submitted to APVMA. (2005):3-23
- 21) FAO/WHO 2002: Manual on Development and Use of FAO and WHO Specifications for Pesticides, 1st Edition, FAO, Rome, (2002).
- 22) USEPA 1997 : Reregistration eligibility Decision on Propoxur, EPA, Washington DC , USA, (1997).
- 23) Latif M.A., M.A. Razaque and M. M. Rahman, Pak J . of Biological Sciences 2007.11, 2018-2029.
- 24) Komal, V.K. S. Dileep, H.C .Agrawal, A.K Dhawan and D .Prem. Impact of insecticide usage on microbes, iron reduction capacity and respiration in soil of cotton fields. Journal of Environmental Science and Health, Vol2 36(4):421-34.

S.S.E.S.A's Science College, Congress Nagar, Nagpur
P.G. DEPARTMENT OF MICROBIOLOGY
PROJECT LIST (2023-2024)

Sr. No.	Name o the Student	Project Title	Supervisor
1.	Akanksha Meshram	Temple waste: A cost-effective source of microbiological media preparation.	Dr. Pranita Gulhane
2.	Ashwini Nandanwar	Medicinal Antifungal Cream Prepared from Lotus & Neem Extract.	Dr. Pranita Gulhane
3.	Asmita Wagh	Evaluation of anti-microbial potential of <i>Andrographis paniculata</i> (leaf extract).	Dr. Pranita Gulhane
4.	Diksha Choube	Efficacy of Bael Leaves Extract to Combat Intestinal Pathogen.	Dr. Pranita Gulhane
5.	Jahnvi Parbat	Antibacterial activity of <i>Bergenia ciliata</i>	Dr. Pranita Gulhane
6.	Kaniz Sheikh	Bioefficacy of anthill bacteria against clinical pathogens	Dr. Pranita Gulhane
7.	Komal Nibrad	<i>Amorphophallus paeoniifolius</i> : a promising antibacterial agent	Dr. Pranita Gulhane
8.	Nimmi Kumbhare	Role of plant based enzyme – a sustainable approach	Dr. Pranita Gulhane
9.	Nisha Khaparde	Prevalence of infectious bacteria from Baby Diapers	Dr. Pranita Gulhane
10.	Prachi Thakur	Formulation and evaluation of herbal mouthwash against Clinical pathogens	Dr. Pranita Gulhane
11.	Pratiksha Teltumbade	Comparative evaluation of herbal and commercial toothpastes	Dr. Pranita Gulhane
12.	Rutuja Meshram	Beet Root- A natural colorant in lip-balm preparation	Dr. Pranita Gulhane
13.	Sejal Nilatkar	Microbiological Quality of Traditional Triable food : Ambil	Dr. Pranita Gulhane
14.	Shivani Vikhar	Evaluation of bacteriological contaminants isolated from poultry feed	Dr. Pranita Gulhane
15.	Simran Bode	Anti-bacterial activity of <i>Colocasia esculenta</i>	Dr. Pranita Gulhane
16.	Sushma Lilhare	Enhancing the antimicrobial efficacy of cow	Dr. Pranita Gulhane

		urine with Neem Extract	
17.	Vaibhav Jaronde	Petroleum Jelly Prepared from Citrus Fruits Extract- An In-Vitro Study	Dr. Pranita Gulhane
18.	Vaishnavi Nannaware	Formulation and Antimicrobial Potential of Antidandruff Shampoo	Dr. Pranita Gulhane
19.	Vaishnavi Shende	Antimicrobial potential of "Panfuti- A Miracle Plant"	Dr. Pranita Gulhane
20.	Vanshika Gandhre	In-vitro bactericidal activity of Alum	Dr. Pranita Gulhane



P. Gulhane
 Dr. Pranita Gulhane

Department of Microbiology
 B.S.P. College, Congress Nagar,
 NAGPUR.

**FORMULATION AND ANTIMICROBIAL POTENTIAL OF ANTIDANDRUFF
SHAMPOO**

Project work
Submitted for
Partial fulfilment of the degree of

**MASTER OF SCIENCE
(M.Sc.-II, Semester-IV)
IN
MICROBIOLOGY**

Submitted by
Ms. VAISHNAVI RAJU NANNAWRE



**Shri Shivaji Education Society, Amravati's
SCIENCE COLLEGE
Congress Nagar, Nagpur-12**

Accredited with CGPA of 3.51 at 'A+' Grade by NACC,
Bangalore A College with potential for Excellence
An Institutional Member of APQN
Recognized Center for Higher Learning & Research
A Mentor College under Paramarsh Scheme of UGC, New Delhi
A Mentor College under Paris Sparsh Scheme of Maharashtra
State
2023-2024

TABLE OF CONTENTS

SR NO.	CONTENT	PAGE NO.
1.	Declaration	I
2.	Certificate	II
3.	Acknowledgement	III
4.	List of Tables	IV
5.	List of Figures	V
6.	Chapter 1: Introduction	01-15
7.	Chapter 2: Aim and Objectives	16
8.	Chapter 3: Review of Literature	17-19
9.	Chapter 4: Materials and Methods	20-28
10.	Chapter 5: Result	29-36
11.	Chapter 6: Discussion	37
12.	Chapter 7: Conclusion	38
13.	Chapter 8: References	39-41

DECLARATION

I, the undersigned hereby declare that the research work presented in this project entitled "**Formulation and Antimicrobial potential of Antidandruff Shampoo**" has been carried out under the guidance and supervision of **Dr. Pranita B. Gulhane**, Assistant Professor & Supervisor, Department of Microbiology, S.S.E.S. A's Science College, Congress Nagar, Nagpur.

This work or any part of this work is based on original research and has not been submitted to any university/Institution for the award of any degree or diploma.

Place- Nagpur

Date -



Ms. Vaishnavi R. Nannawre

CERTIFICATE

This is to certify that the research work presented in this thesis entitled, "**Formulation and Antimicrobial potential of Antidandruff Shampoo**" is the own work of **Ms. Vaishnavi Raju Nannawre** conducted in P.G. Department of Microbiology, S.S.E.S. A's Science College, Congress Nagar, Nagpur under my supervision.

This work has not been submitted earlier to any other University/Institution for the award of any degree or diploma.

Place-Nagpur

Date- 18/05/2024



Dr. Pranita B. Gulhane
Assistant Professor & Supervisor
Department of Microbiology
Science college, Congress Nagar,
Nagpur

Department of Microbiology
Science College, Congress Nagar,
NAGPUR.

Evaluated

ACKNOWLEDGEMENT

*Special thanks to **Hon'ble Prof. M.P. Dhore sir**, Principal, Science College, Congress Nagar, Nagpur for providing the platform to carry out research work. I am grateful for his moral support throughout the research period.*

*It is indeed my proud privilege to express my deep sense of gratitude to my admired teacher, **Dr. Pranita B. Gulhane madam**, Assistant professor & Supervisor, Department of Microbiology, Science College, Congress Nagar, Nagpur for her immense help, cooperation and valuable guidance that she has extended to me for the successful completion of this project.*

*I express my sincere gratitude and thanks to my guide **Ms. Anjali Pogade madam** and all teachers **Ms. Sayali Sangole madam**, **Ms. Triveni Pardhi madam** and **Ms. Ankita Manpure madam** of the department for their academic help during the period of my project work.*

I express deep appreciation to non-teaching and technical staff of the Department for their cooperation and technical assistance.

*I am very much thankful to my beloved parents. As with blessings of my father **Mr. Raju Nannawre** and immense moral support, love, care, and concern of my mother **Mrs. Sharyu Nannawre** much required for successful completion of this project. I wish to express my sincere thanks to my friends **Rutuja** and **Asmita** and my entire batch for helping me out morally throughout my research period.*

I wish to express my sincere thanks to all those who helped me directly or indirectly throughout the project. Thank you.

I would like to praise and thank God, the Almighty, who has granted countless blessing, knowledge, and opportunity to the writer, so that I have been finally able to accomplish the thesis.

Thank you

- Ms. Vaishnavi Raju Nannawre

LIST OF FIGURES

Fig. No.	Title of figure	Page No.
Fig. 1	Sample photo of dandruff	02
Fig. 2	Dry skin dandruff	03
Fig. 3	Oily skin dandruff	04
Fig. 4	Fungus related dandruff	05
Fig. 5	Psoriasis related dandruff	06
Fig. 6	Eczema dandruff	06
Fig. 7	Amla	10
Fig. 8	Neem	11
Fig. 9	Shikakai	12
Fig. 10	Bhringraj	13
Fig. 11	Reetha	14
Fig. 12	Preparation of plant extracts	22
Fig. 13	Formulation of herbal shampoo	25
Fig. 14	Isolation and identification of sample 1 and 2	29
Fig. 15	Inoculum preparation of both samples	29
Fig. 16-25	Phytochemical analysis of amla, neem, shikakai, bhringa, reetha	30-33
Fig. 26-27	pH measurement	34
Fig. 28	Foam ability test	34
Fig. 29	Dirt dispersion test	34
Fig. 30-31	Antifungal activity of herbal shampoo	35-36

CHAPTER I: INTRODUCTION



Introduction

Dandruff is a scalp disorder whose characteristic feature is excessive shedding of skin cells from the scalp. It is a common problem faced by people of all age groups. It is one of the major cosmetic problems as it ultimately leads to hair fall. *Malassezia furfur*, a lipophilic basidiomycetous fungus is a causative organism for dandruff. As dandruff is globally prevalent, it needs an effective therapeutic remedy. Presently people are depending on commercial shampoos as a treatment for dandruff. However, plant products contain various compounds like alkaloids, flavonoids, tannins, terpenoids etc. which have efficient antifungal activity. The effect of commercial antidandruff shampoos and natural plant products to evaluate their anti-fungal efficacy leads to the conclusion that the activity of some of the natural extracts was equivalent to that of the commercially available branded shampoos. As crude herbal drugs have been included in traditional medicine and household remedies for a long time, regular usage of these tested plant extracts can reduce the incidence of dandruff. (K. S. Raju, 2019).

Dandruff is a skin condition that mainly affects the scalp. Flaking and sometimes mild itchiness are the main symptoms of dandruff. It is a common scalp disorder and also a major cosmetic problem as it leads to hair fall problems (Ravichandran, G. and Shivaram Kolhapur, S.A., 2004). It can result in social or self-esteem problems. It is a common problem faced by people of all age groups.

The underlying mechanism of dandruff involves the overgrowth of skin cells. As the epidermal layer continuously replaces itself, the cells are pushed outwards, where they gradually die and flake off. For most individuals, these flakes of skin are too small to be visible. However, certain conditions cause cell turnover to be unusually rapid, especially in the scalp. It is hypothesized that for people with dandruff, skin cells may mature and be shed in 2-7 days, as opposed to around a month in people without dandruff. The result is that dead skin cells are shed in large, oily clumps, which appear as white or greyish flakes on the scalp, skin and clothes (De Angelis Y. M, et al., 2005).

It is a known fact that there is no complete cure for this disease. As this disease is known to occur all over the world it needs effective therapeutic remedy. There are natural effective remedies to control dandruff in Ayurveda (Sonica Krishnan, 2011), but nowadays people are depending on commercial shampoos containing antifungal compounds like miconazole, ketoconazole, selenium sulphide etc. Plant products contain various compounds like alka-

oids, flavonoids, tannins, terpenoids etc. which have efficient antifungal activity (Agrawal DP, 2001, Saneesh Kumar, 2013).

What causes dandruff?

There are plenty of reasons for the cause of dandruff. It is hard to conclude what exactly causes an itchy and flaky scalp. Some of the well-known causes of dandruff are:

- Dry skin
- Oily skin
- High sensitivity to air care products
- Skin conditions like Psoriasis and Eczema
- Malassezia, a yeast-like fungus that feeds on oil
- Sebaceous glands Secretion
- Fungal colonization on the skin surface
- Overexposure to sunlight
- Exposure to dust or dirt
- Eat Routine
- Pressure formed on scalps due to wearing hats



Fig: 1. Dandruff on the scalp.

Types of dandruff

There are several types of dandruff, each with a unique cause. Some types can be treated easily with changes to your hair care routine or with dandruff home remedies. Other types of dandruff may require prescription medications. There are some types of dandruff and the underlying causes of each:

1. Dry skin dandruff

This is a common type of dandruff. It tends to happen more often in the winter months as cold weather and indoor heating can dry out your skin, including the skin on your scalp. Washing your hair frequently in hot water can also lead to dry skin dandruff. A scalp that's too dry can become irritated and shed skin cells. Dry skin dandruff flakes are small and white. Your scalp may feel itchy, but not excessively so.

If the itchiness becomes severe, you may have a more serious skin condition that requires a medical professional's care. To help prevent dry skin dandruff, use a moisturizing shampoo. Coconut oil massages, may also help relieve itchiness and prevent the skin on your scalp from drying out.

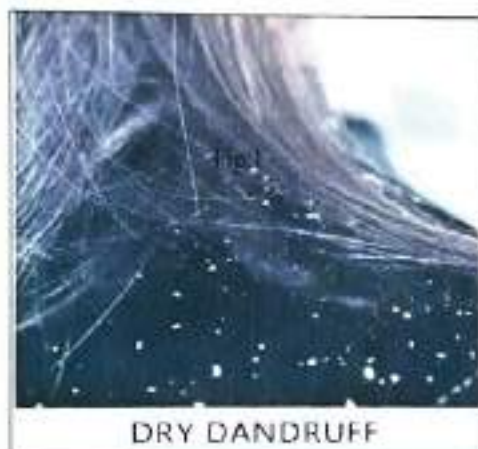

Fig :2 Dry dandruff

The weather could also be causing your condition. Environments with low humidity and areas located in cold climates can dry out the skin on your scalp. In addition, as you get older, the skin starts to dry out. However, the condition can occur for more serious reason too. On the other hand, dry skin happens when skin losses too much water.

Dandruff flakes are bigger, and they look oily. In babies with cradles cap, their scalp looks scaly or crusty. Both dryness and dandruff can make your scalp itch.

2. Oily skin dandruff

Just below the surface of your skin are glands that produce sebum, an oily substance that helps moisturize and protect your skin. When these sebaceous glands produce too much sebum, it can make hair oily. Also, the excess oil can clump together, irritating the scalp and causing dandruff.

Oily skin dandruff flakes tend to be larger than dry skin dandruff. The flakes may look more yellow than white, and may appear oilier, too.

Seborrheic dermatitis is a more severe form of oily skin dandruff.



Fig:3 Oily dandruff

The fungus feeds on oil and breaks it down into products that can react with your scalp. But when your scalp has excess oil, it provides fertile ground for this fungus to explode.

The whole point of this secretion is to coat your scalp and hair in a protective layer. The sebum is supposed to flow down in hairs strands and prevent them drying out. But if the scalp starts producing excessive amounts of sebum, it can create a thicker layer on hair, which ultimately leads to dull and lifeless oily hair.

3. Fungus-related dandruff

A type of common fungus called *Malassezia* is found on the skin of every human being. In some people, it can trigger an inflammatory response that produces dandruff or other conditions, such as eczema. This fungus survives on excessive scalp oil and produces oleic acid as a byproduct. This in turn causes a build-up of skin cells, which fall down as white flakes.



Fig:4 Fungus related dandruff

The fungus lives on the scalp of most healthy adults without causing any problems. One theory shows that the immune system of someone with dandruff may overreact to that fungus. Dandruff may get worse when someone gets stressed or sick.

This fungus feed on oils secreted by our hair follicles and usually doesn't cause any problems unless it grows out of control leading to an increase in cell turnover rate resulting in visible dandruff flakes.

Unfortunately for some people, the skin reacts to this oleic acid with inflammation and accelerated cell turnover. The scalp gets irritated and starts shedding skin cells faster than usual that results in dandruff.

Skin also influences dandruff development. People with dry skin tends to experience more frequent bouts of dandruff, especially during colder months when air humidity level drop.

This lack of moisture can lead to flaky skin on your scalp and subsequently cause dandruff. Well, the personal hygiene habits are might also be contributing factors.

4- Psoriasis-related dandruff

Psoriasis often presents with more severe symptoms, such as plaques, bleeding, and itchy or burning skin. It develops when a person's immune system malfunctions and tells skin cells to grow too quickly.



Fig :5 Psoriasis related dandruff

New skin cells form in days rather than weeks. The body does not shed these excess skin cells. The skin cells pile up on the surface of the skin, causing patches of psoriasis to appear.

5- Eczema dandruff

The shedding of white flakes is the most noticeable symptoms of scalp eczema. This is an inflammatory skin condition that causes rashes, scaly skin, itching, and sores. It is often categorized as one of the many types of dandruff due to the flaking, but is more commonly found. It can be a stubborn condition that may persist for years. Symptoms of scalp eczema can be effectively managed, but this condition cannot be cured completely.



Fig :6 Eczema dandruff

There are numerous triggers that worsen scalp eczema symptoms. Those triggers include extreme weather (particularly cold, dry weather) and stress.

Some other potential triggers for scalp eczema:

- Hormonal changes
- Illness
- Stress
- Harsh chemicals from detergents and soaps
- Heavy alcohol use or alcohol-based lotions
- Medications such as psoralen (for psoriasis), interferon, and lithium.
- Heavy sweating
- Exposure to an allergen
- Nervous system disorders, including Parkinson's disease, traumatic brain injury, stroke, and epilepsy
- Allergies or a family history of allergies, like hay fever, asthma, and atopic dermatitis
- Obesity

● **Factors affecting Dandruff:**

1- Having dry skin

Dry skin is one of the most common causes of dandruff. If dry skin is causing dandruff, it's easier to tell as other places of the body are mostly likely dry as well. During cold months, skin becomes drier-which why people tend to notice more dandruff at this time. When dry skin causes dandruff, the flakes are usually smaller and less oily than the flakes caused contact dermatitis.

2- Bad hair hygiene

While it sounds unhygienic, not shampooing enough could be the cause of the dandruff. When someone don't shampoo enough, oil accumulates and builds up on the skin and

cause dandruff. It could be that not using enough shampoo, or that the shampoo using isn't strong enough to break down the oil barrier that is contributing to the dandruff.

3- Allergy:

From grass to peanuts, people are allergic to a wide variety of substances. Certain hair products can cause sort of scalp irritation such as itchiness or soreness after using that product. It could be because of a sensitivity or kind of allergies.

4- Medical condition:

Seborrheic dermatitis is a chronic medical condition that only affects the scalp but also other areas of the body where oil glands are present. This condition is characterized by dandruff as well as redness of the scalp. It looks similar to other common skin diseases like psoriasis, eczema or even an allergic reaction.

5- Yeast overgrowth:

Malassezia is a fungus that lives on the scalp and skin of all people. For some, a sensitivity develops which can result in dandruff. Like seborrheic dermatitis, other skin conditions aggravated by Malassezia include psoriasis and other type of dermatitis.

6- Sex:

Androgen hormones, such as testosterone, stimulate activity in the sebaceous glands. More oil means an increased chance of an inflammatory reaction and dandruff. Men are more frequently affected by dandruff than women. A man scalp contains 50% more sebum than a women's scalp. The difference is primarily based on -

- a. **Sebum amount:** As soon as the puberty hits, sebaceous glands start actively secreting sebum. The sebum secretion rate stays high from around 15 to 35 years old. As the age beyond 35 years old, sebum production slows down. In women, sebum production gets increasingly slower after the menopause. Throughout this period of sebum secreting activity, production rates in men remain higher than in women. This contributes to the disproportionate amount of scalp flaking disorders and skin irritation between men and women (Kim, S. et al., 2021).

- b. **Sebum composition:** Men naturally have a higher percentage of heavy material like triglycerides and cholesterol esters in their sebum. Contrarily, women's sebum has a higher percentage of volatile and lighter components like fatty acids. Such sebum composition differences between men and women affect scalp conditions (Gender differences in scalp health, 2022).
- c. **Protein loss:** One of the primary differences is that the loss of protein in men is higher. A study found in 2017 found that men experience more protein loss from their scalp than women. As a result, they have a higher chance of developing dandruff, which alongside increased sebum production can lead to hair loss. Since men experience more protein loss and sebum secretion, they may need to pay more attention to their scalp care to prevent hair loss and dandruff (Gender differences in scalp health, 2022).
- d. **Skin barrier function:** The stratum corneum (SC) is the skin's outermost layer, which protects the skin and helps to retain its moisture. In men's scalp, the SC's level of ceramide is lower. This can cause a weakening and reduced function of the skin barrier. Therefore, surfactants can more easily penetrate the epidermal layer and damage the skin protein (Xu, Z. et al. 2016). Weaker skin barrier function can lead to various skin problems, like dandruff, men's dry scalp and skin sensitivity, and itchiness. It means men are at higher risk of developing itchy, flaky, and/or oily scalps. Comparatively, women's scalp barriers are stronger, so they are likely to have these issues. (Kim, S. et al., 2021).

• **Plants used in the preparation of Herbal shampoo: -**

1) **Amla (*Phyllanthus emblica*):**

Scientific classification:

Kingdom: Plantae
 Division: Angiospermae
 Class : Dicotyledonae
 Order : Malpighiales
 Family : Phyllanthaceae
 Genus : Phyllanthus
 Species : Phyllanthus *emblica* L.

Amla is generally known as an Indian Gooseberry. The berries of the trees are potently used for the medicinal formulation also. Amla tree contain small berries that are round and yellowish-green in color. It is packed with the vitamin C and anti-oxidants which can help reduce premature ageing of the skin and the hair. It has high concentration of vitamin C which is even higher than oranges.



Fig: 7 Amla

Traditional medicines have long used amla powder for dandruff. It utilizes the properties of amla to go after the root cause of dandruff, which is usually excessive oil on the scalp. It also hydrates the skin and prevents it from drying out. It has anti-inflammatory properties that can calm down skin irritation. This comes handy for itchy scalp or skin. Amla attacks the oil build-up and the dandruff causing germs. It tries to regulate the oil level on scalp and stop the growth of fungus. The increased blood circulation also brings nutrients to the head. This is why amla used as a method on how to get rid of dandruff (Internet source - www.headandshoulders.co.in).

2) **Neem (*Azadirachta indica*):**

Scientific classification:

Kingdom : Plantae

Division : Magnoliophyta

Class : Magnoliopsida

Order : Sapindales

Family : Meliaceae

Genus : *Azadirachta*

Species : *A. indica*

Neem is a natural herb from the neem tree, other names for which include *Azadirachta indica* and Indian lilac. There are some potential health benefits of neem, but it is also possible for someone to have a neem allergy or sensitivity. Neem is a popular ingredient in



Fig :8 Neem

several anti-dandruff shampoo. Neem is an anti-inflammatory and anti-microbial, which may reduce the symptoms associated with dandruff (www.medicalnewstoday.com). Neem is a very good moisturizer. It contains vitamin E and fatty acids, which makes the skin smooth a soft. It gives a scalp that is free from dryness and flaky skin. Neem is an expert when it comes to treating hair dandruff and itchy scalp. It makes hair follicles strong and reduces hair fall at the same time. Neem helps to improve hair texture and keeps hair loss and breakages away. Neem has a special power that helps to prevents premature greying of hairs. Neem has antibacterial and antifungal properties that reduces the side effects of dandruff, dry scalp and scalp infection. roots become stronger and healthier as a result of improved blood circulation in scalp (Internet source -www.healthshots.com).

3) Shikakai (*Acacia concinna*) :

Scientific classification:

Kingdom : Plantae
Division : Magnoliophyta
Class : Magnoliopsida
Order : Fabales
Family : Fabaceae
Genus : *Acacia*
Species : *A. concinna* (*Shikakai*)

Shikakai which means 'fruit of hair' is a part of the traditional Indian Ayurvedic medicine. It is an herb especially used for controlling hair fall and dandruff. Shikakai can be used alone or in combination with reetha and amla as a shampoo to help manage hair fall and prevent dandruff due to its cleansing and antifungal properties. It provides shine to the hair



Fig: 9 Shikakai

as well as prevents its greying. According to Ayurveda, applying Shikakai powder along with rose water or honey to wound help in faster healing due to its Ropan [healing] property and Sita[cold] nature. Shikakai may naturally soften and smoothen hair by releasing essential oils and vitamins that are important for hair growth. It may encourage hair development and may help to maintain hair silky and lustrous. When used for hair, shikakai may help with the restoration of hair's glossy texture, thickness and length. It is said to boost hair growth and strengthens the hair strands. It contains vitamins A, C, E and K, which helps to give thicker hair and increase the blood circulation to the scalp. By boosting sebum production, it can prevent the scalp from drying out. Shikakai is useful as an anti-dandruff agent because of its unique ability to cleanse without irritating the scalp. It is especially useful for controlling chronic dandruff due excessive oil on the scalp. Applying Shikakai helps to remove excess oil from the scalp and controls dandruff when used regularly (Hanif MA, et al. 2010).

4) Bhringraj (*Eclipta alba*):

Scientific classification:

Kingdom : Plantae
Division : Tracheophyta
Class : Magnoliopsida
Order : Asterales
Family : Asteraceae
Genus : Eclipta
Species : *Eclipta alba* (L.) Hassk.

Bhringraj is also known as Kesharaj which means 'Ruler of the hair'. It is rich in proteins, vitamins and antioxidants which helps to protect the body against certain infections. Bhringraj is effective in promoting hair growth as well as reducing the greying of hair.



Fig: 10 Bhringraj

This is due to the presence of various nutrients in Bhringraj that provide nourishment to the hair scalp. According to Ayurveda, Bhringaraj rejuvenates the skin and thereby helps to reduce the signs of aging such as fine line, wrinkles and patchy skin due to its anti-aging property. Bhringaraj along with a carrier oil (coconut oil) can be used to manage skin infection and allergies due to its antimicrobial property. (Banerjee A, Shrivastava N, Kothari A, et al. 2005).

In Ayurveda, an Indian tradition that aims to balance and heal the body through nutrition, bhringaraj is said to promote hair growth, strengthen hair, and prevent graying and dandruff. Various types of dandruff usually occur due to excessive dry scalp, humidity in the air and lack of hygiene and eventually leads to itching and flaking. Bhringaraj not only has a powerful anti-microbial, anti-bacterial properties but also has a high specific gravity, which allows it to penetrate deep inside the scalp and itching (Internet source M.netmeds.com).

5) Reetha (*Sapindus mukorossi*):

Scientific classification:

Kingdom	: Plantae
Division	: Tracheophytes
Class	: Magnoliopsida
Order	: Sapindales
Family	: Sapindaceae
Genus	: Sapindus
Species	: <i>S. mukorossi</i>

Reetha or Soapnut is also called as Arishtak in Ayurveda and 'Soap nut tree' in India. It is well known for its traditional medicinal uses and is commonly used as a hair cleanser. Reetha is extensively use to make natural hair care product as it makes hair shiny, healthy and lustrous. It can be used on daily basis to provide nourishment to the the hair scalp and



Fig:11Reetha

promote hair regrowth. Reetha powder can be mixed with warm water to form a paste which can be used to massage the scalp to help manage dandruff and also remove lice from the scalp due to its insecticidal property. The Reetha can be applied to hair to help to control greying of hair and also stimulate better hair growth.

According to Ayurveda, dandruff is a condition marked by flakes of dry skin on the scalp. This may be due to an aggravated Vata and Pitta dosha. Reetha helps to control dandruff and promotes hair growth due to its Tridosha balancing property. The Tiksha (sharp) nature of Reetha also helps to keep the scalp dandruff-free. Reetha helps to reduce itching as well as inflammation because of its Tridosha balancing property. Fungal infection on the scalp is of the most common causes of the dandruff. Reetha for hair has antifungal properties that can help combat dandruff-causing fungi, keeping the scalp healthy and dandruff free. Reetha tree contains natural saponin, which have excellent cleansing properties, making it a popular ingredient in natural soaps and shampoo (Shah AH, Dutta K, Deka DC, 2014).

● Benefits of Herbal Shampoo -

The herbal shampoo has several benefits that go well beyond just cleaning the hair. An all-encompassing approach to hair care is offered by herbal shampoos, which harness the power of organic components and botanical extracts. Some of the benefits are discussed below-

- Herbal shampoos are free from harsh chemicals, sulfates, and synthetic fragrances, that make them gentle on the scalp and hair.
- Herbal shampoo is known for their nourishing properties, helping to moisturize and hydrate the hair while maintaining its natural pH balance.
- Most herbal shampoo are enriched with vitamins, antioxidants, and essential oil, promoting healthier hair growth and minimizing damage.
- Herbal shampoo often caters to specific hair concerns, such as dandruff control, hair fall reduction, and overall scalp health, offering tailored solutions for individuals with diverse needs.
- They usually have soothing and calming scents, derived from natural sources, and also contribute to a more pleasant and relaxing shower experience.
- Herbal shampoo is often committed to natural ingredients and sustainable practices.
- Prolonged exposure to harsh UV rays and the sun can damage hair cuticles and scalp. Natural ingredients used in herbal shampoo are filled with essential antiseptic properties that act as a shield to protect hair and scalp from the harsh UV rays of the sun thus preventing scalp from damage and hair breakage.
- The cleaning action of synthetic shampoo removes oil contents from the hair leaving the hair dry and frizzy. Whereas, herbal shampoo aims at providing essential nutrients to the hairs and at the same time have a mild cleansing effect to remove the excess oil content from the hair.

CHAPTER II: AIM AND OBJECTIVE



Chapter 2: Aims and Objectives-

- **Aim-** The aim of the present study was to formulate and evaluate antimicrobial potential of anti-dandruff shampoo.
- **Objectives-** The objective of the study were:
 - To collect the samples.
 - To analyse the phytochemical test of herbal ingredients (aqueous and ethanolic) extract.
 - To formulate the herbal shampoo.
 - To evaluate the herbal shampoo.
 - To study the antifungal activity of the herbal shampoo.

Chapter 2: Aims and Objectives-

- **Aim-** The aim of the present study was to formulate and evaluate antimicrobial potential of anti-dandruff shampoo.
- **Objectives-** The objective of the study were:
 - To collect the samples.
 - To analyse the phytochemical test of herbal ingredients (aqueous and ethanolic) extract.
 - To formulate the herbal shampoo.
 - To evaluate the herbal shampoo.
 - To study the antifungal activity of the herbal shampoo.

CHAPTER III: REVIEW OF LITERATURE



Chapter 3: Review of Literature

Dandruff is chronic condition characterized by scaling, itching and redness of the scalp. It occurs when scalp sheds epidermal cells in large clumps. The skin of the scalp renews itself about once a month. Usually, scalp sheds dead cells are shed as invisible flakes sometimes cell turnover becomes unusually rapid and dead cells are shed as visible flakes called dandruff. (Loden & Wessman, 2000)

According to the symptoms dandruff is classified into two types- Dry (common) and Oily. Dry dandruff also known as Pityriasis simplex is characterized by excessive formation of minute scales of white greyish or ashen color, accumulating on the scalp area. These scales are at first localized in the middle of scalp area and then spread towards parietal, frontal and occipital areas. Other type of dandruff is called oily dandruff or Pityriasis steatoides. It arises on scalp skin with varied intensity of sebum production. Inflammation of varied intensity develops on the scalp skin with the appearance of oily scales of dirty yellow color that can form lesion. The most common affected site by dandruff is scalp, but it can occur between eyebrows, along the side of nose, behind the ears, over the breastbone. (Nowicki, 2006)

In developing countries, it has been seen that increase in research using the medicinal plants in the treatment of microbial infections. It has stated that the plants extract which has antidandruff properties can be used efficiently as a substitute to chemical drugs due to insufficient number of drugs, high toxicity and prolonged treatment (Duraipandiyar et al., 2011).

Shampoo is typically composed of 10-12 ingredients although products with as few as four ingredients are available. The products are grouped into (1) Cleansing agents, (2) additive that contribute to the stability and comfort of the product, (3) conditioning agents, intended to impart softness and gloss, to reduce flyaway and to enhance disentangling facility, and (4) special care ingredients, designated to treat specific problems, such as dandruff and greasy hair. (Maria Fernanda Reis Gavazzoni Dias Hair Cosmetics: January, 2015).

Dandruff is a scalp whose characteristics feature is excessive shedding of skin cells from the scalp. It is a common problem faced by people of all age groups. It is one of the major cosmetic problems as it ultimately leads to hair fall. A lipophilic basidiomycetous fungus is a causative organism for dandruff. As dandruff is globally prevalent, it needs an effective

therapeutic remedy. Presently people are depending on commercial shampoos as a treatment for dandruff. However, plant products contain various compounds like alkaloids, flavonoids, tannin, and terpenoids etc. which have efficient antifungal activity. The effect of commercial antidandruff shampoo and natural plant products to evaluate their anti-fungal efficacy led to the conclusion that the activity of some natural extracts was equivalent to that of commercially available branded products. As crude herbal drugs have been included in traditional medicine and household remedies for a long time, regular usage of these tested plant extracts can reduce the incidence of dandruff. (Kutcharlapati Sunita Raju: International Journal of Advance Research, Ideas and Innovations in Technology, 2019).

The review of this study is to formulate and evaluate herbal shampoo for cosmetic purpose from herbal ingredients. Neem powder, Amla powder, Shikakai powder, Ritha powder etc. was prepared by homemade method, then prepared the decoction of the ingredients and mixing with each other and evaluated its organoleptic and physicochemical characteristics. Herbal shampoo is used to cleansing of the hair and also conditioning, smoothing of the hair surface, good health of hair, hair free of dandruff, dirt grease, and lice above all, its safety benefits are expected. The advantage of the herbal cosmetics is their non-toxic nature, reduce the allergic reaction and time-tested usefulness of many ingredients. Thus, in present work, found good properties for the herbal shampoo and further optimization study benefits of herbal shampoo on human use as cosmetic product. (P D. Gaikwad, K. V. Mulay, M D. Borade, Formulation and evaluation of Herbal Shampoo, 2020).

The plant samples were collected from nearby areas. Aqueous and ethanolic extracts of leaves and flower of the plants were prepared. The presence of flavonoids, steroids, saponins and tannins are associated with the antifungal activity of these extracts. The dandruff collected from the people with the visible flakes was inoculated on sterile Sabouraud dextrose agar (SDA) incubated at 32 C to 37 C for 3 to 5 days. Identified fungal species was isolated by the pure culture in Sabouraud dextrose agar medium. The aqueous and ethanolic leaf and the flower extract showed higher antifungal activities were tested by the Agar well diffusion Method (S. Santhi et al., January, 2022).

Shampoo is the cleansing preparation of the hair and scalp. Though there are different types of the skin cleanser, but the hair cleanser preparations can be grouped into only one category and are called as shampoo. They are basically water-based product containing mainly surfactants. Its primary function is of cleaning the hair of accumulated sebum, scalp debris and

residues of hair grooming preparations. The herbal shampoo although better in performance and safer than the synthesis ones will be popular with consumers.

- The selection of the active ingredients for hair care shampoo is often based on the ability of the ingredients to prevent damage to skin as well as to improve quality of the skin by way of cleansing, nourishing and protecting the skin.
- It has not made the hand rough and chapped.
- It's not given any side effects of causes irritation to the eyes.
- It produces a good amount of foam to satisfy the psychological requirements.

The purpose of this review is to gather information related to the herbal shampoo. In day-to-day life hair care is of prime importance. A good care of hair can be taken by use of different cosmetics products like hair oil, hair shampoo, hair gel, hair serum, hair cream etc. For cleansing and nourishing purpose shampoo are widely used by many people as it contains cleansing agents. But with this many chemicals are chemicals are also involved which may damage health of hairs by continuous use. To encounter this herbal shampoo can be used which makes less damage to hairs by giving good results as it contains natural ingredients. Many herbal crude drugs are used in shampoo formulation like shikakai, amla, reetha, bhringraj etc. These drugs are used in formulation by taking its aqueous extracts with other natural or synthetic excipients. These formulations of shampoo with one more herb can be characterized by different methods like pH, Foam formation (Shak test), Skin irritation test, Visual stability, Viscosity, DIRT dispersion, Estimation of conditioning performance, Microbial control assement, Microbial limits test etc. The main object of this to present study is to prepare and evaluate herbal shampoo and determine physiochemical function that emphasizes on safety, efficacy and quality of the product (S V. Sirsat et al., April 2022).

CHAPTER IV: MATERIALS AND METHODS



Chapter 4: Materials and Methods:

- **Materials:**

- **Sample:**

Fungi 1-Sample-A

Fungi 2- Sample-B

Plantmaterials:

1-Amla powder

2-Neempowder

3-Shikakai powder

4-Reethapowder

5-Bhringraj powder

6-Almond powder

7-Flexseedpowder

- **Requirements:**

Media:

Saubouraud's Dextrose Agar, Potato Dextrose Agar.

● Methods:

1. Materials sterilization:

All the glass wares used for the experiments were properly washed, dried and sterilize in the autoclave on 15 lbs pressure at 121°C for 60 min. The entire working surface were also disinfected with ethanol to reduce contaminations.

2. Collection of samples:

Scrapping of dandruff was collected from the people with the help of moist swab and brought to the laboratory for the further analysis & processed within 2hrs.

3. Isolation of the micro-organism:

The collected sample was streaked on the Sabouraud's dextrose agar plates. The plates were incubated at 25°C for 5-7days at room temperature for fungal growth.

The isolated fungi were then studied by staining them with the lactophenol cotton blue A drop of lactophenol cotton blue stain was plated on a clean dry slide. Using a needle the fungal culture was teased carefully. Cover slip was placed and observation were made under microscope.

4. Inoculum preparation:

The inoculum of fungi 1 and fungi 2 was prepared by inoculating in 5ml of Sabouraud's broth and incubated at 25°C.

5. Collection of plants:

Fresh leaves/fruit of Amla, Shikakai, Neem, Bhringaraj, Reetha and Hibiscus were collected. The leaves/fruit of different plants were washed to remove debris and dirt remains and allow to dry at room temperature. The dried sample were separately blended into fine powder.

6. Preparation of the extract:

5gm powder leaves were added in 50 ml ethanolic and aqueous solution. This task one placed in rotary shaker machine for 24hrs.

After 24hrs, the mixture is filter with what man filter paper i.e. the plant extract and used for further analysis.



Fig:12 Preparation of extract

7. Phytochemical Analysis Test:

Phytochemical have a great antioxidant potential and their beneficial effects on human health, and they give greater health benefits to the consumers.

Phytochemical are chemicals of plants origin. Phytochemicals (from Greek phyto, meaning "plant") are chemicals produced by plants through primary or secondary metabolites.

They generally have biological activity in the plant host & play a role in plant growth or defense against competitors, pathogens or predators (Monika Thakur et.al., 2020).

1- Test for Tannin:

Tannins, the second most abundant polyphenol, mainly function as defense compounds that protect plants against abiotic stresses, such as drought, heat, and high UV radiation (Vidya Sussela, 2019).

2ml of extracts was dissolved in 5ml of distilled water. To this few drop of natural 5% ferric chloride solution was added. A dark green to blue green or blue-black color indicated the presence of tannin.

2- Test for Saponin:

Saponin is a large family of structurally related compounds containing a steroid or trit-aglycone(sapogenin) linked to one or more oligosaccharides moieties (V. R. Mohan et al., 2016).

2ml extract was dissolved with distilled water up to 10ml & this is shaken for 15 mins in a graduated cylinder. The formation of 2cm thick foam indicated the presence of saponin.

3- Test for Flavonoid:

Flavonoids are health promoting and disease preventing dietary supplements. Flavonoids also possess antiviral, antibacterial and antifungal effects (Pon Velayuthan Anandh Babu et al., 2009).

2ml extract was treated with few drops of sodium hydroxide & the intense yellow color solution becomes colorless on addition of dilute acid proved the presence of the flavonoids.

4-Test for Glycosides:

Glycosides are secondary metabolites that comprise of a sugar portion that is linked to non-sugar moiety (typically a monosaccharide) (Onalapo A. Y et al., 2019).

2ml of extract was added to 2ml of sulphuric acid. Then reddish-brown color was formed indicated the presence of steroidal part of glycosides.

5- Test for Phenol:

Phenol is a bio-active compound derived from plants and foods (Kevin Robards et al., 2003)

1ml of extract was added in 2ml of distilled water then added few drops of 10% ferric Chloride, formation of blue green indicates the presence of phenols.

6. Test for Steroids:

Plant steroids, the brassinosteroids (BRs), are compounds that exerts a wide range of bio-
sbiotic and biotic stresses. They are essential for plant growth, reproduction, and responses to various

1ml of extract was added in 10 ml of chloroform then added equal amount of sulphuric acid
from the walls of test tube and shake. Formation of reddish blue color, green fluorescence
indicates the presence of steroids.

8. Formulation of Herbal Shampoo:

Table no 1: Formulation of herbal shampoo

Ingredients	Quantity (in gms)
1.Amla powder	10gm
2.Neem powder	5gm
3.Shikakai powder	15gm
4.Bhingraj powder	5gm
5.Reetha powder	15gm
6.Almond powder	4gm
7.Flax seed powder	4gm

● **Preparation method of herbal shampoo:**

- Weigh all the ingredients according to the formula.
- Decoction of Hibiscus, Neem, Amla, Ritha, Shikakai, and Bhringraj was prepared in one part of water.
- Filter it, by using muslin clot. Collect filtrate.
- Decoction of Shikakai, and Ritha was prepared in another part of water.
- Filter it by using muslin cloth. Collect filtrate.
- Boil the all filtrate in the same water on medium flame and then add the flex seed powder and also add almond powder as preservative in it.
- Developed shampoo was stored in a suitable container and used for further evaluations (B. M. Mithal and R. N. Saha, 2003).



Fig:13 Preparation of herbal shampoo

● Evaluation of Herbal Shampoo:

To evaluate the prepared formulations quality controls tests including visual assessment and physiochemical controls such as pH were performed. Also to assure the quality of products, specific tests for shampoo formulations including the determination of dry Residue and moisture contents test were carried out (A. R Mainkar and C. Jolly 2001).

● **Physical appearance / visual assessment.**

The formulation prepared were evaluated in terms of their clarity, foam producing ability and fluidity.

● **Determination of pH**

The pH of shampoo solution in distilled water was determined at room temperature by using pH paper or pH meter.

● **Dirt dispersion**

Two drops of shampoo were added in large test tube contain 10 ml of distilled water. One drop of ink was added in the test tube, was stopped and shake for ten times. The amount of ink in the foam was estimated as none, light, moderate or heavy.

● **Skin sensitization test**

This test is performed on skin of human volunteers and checks whether it irritation on skin or not.

● **Stability test**

Stability and acceptability of organoleptic properties (odor and color) of formulations during the storage periods of 2 months indicated that they are chemically and physically stable.

● **Foaming ability and Foaming stability**

Cylinder shake method was used for determining foaming ability. The 4ml shampoo was put in 50 ml of water and covered the cylinder with hands and shaken for 10 times. After 1 minute observe the foam formed by shampoo.

● **Nature of hair after washes**

Nature of hair after wash can be done by collecting the responses of volunteers.

• Antifungal Activity:

Antifungal activity of the herbal shampoo was carried out by agar well diffusion technique.

- To test the antifungal activity of the herbal shampoo was dissolved in distilled water to concentration of 100mg/ml.
- Prepared the potato dextrose agar plates.
- Fungi 1 and fungi 2 were grown on the slants of the sabouraud's dextrose agar and incubated at 37°C for 24hours.
- Colonies of fungi 1 and fungi 2 from this slant were inoculated in sabouraud's dextrose broth in different test tubes and incubated for 24 hours.
- Then, 3 wells with the diameter of 6 to 8 mm are punched aseptically with a sterile cork borer or a tip, and a volume (100µL) of the herbal shampoo at desired concentration is introduced into the well. Then, potato dextrose agar plates are incubated for 24hours at 37°C. The antimicrobial agents diffuse in the agar medium and inhibit the growth of the fungi tested.
- After incubation period the diameter of inhibition zone were measured and recorded in millimeters by using transparent scale and then evaluated (Finn, K.

Chapter 5: Result

Isolation and identification of fungi 1 and fungi 2 from collected samples:



Fig: 14 sample 1 and sample 2

Preparation of inoculum of fungi 1 and fungi 2:



Fig: 15 Preparation of inoculum of both the sample

• Phytochemical analysis of plant extract:

The present study was to formulate the herbal shampoo by using natural ingredients and testing the phytochemical present in the natural ex-tracts and studied antimicrobial property against infectious pathogen.

The phytochemical analysis showed that the natural plant extracts contain some secondary metabolites. The tables below show the presence and absence of phytochemical steroids, glycoside etc. Secondary metabolites are present in plants which is responsible for their therapeutic activity.

1-Amla

Table no: 2- Phytochemical analysis of Amla

Test	Aqueous	Ethanolic
Flavonoid	+	+
Saponin	+	+
Phenol	+	+
Tanin	+	+
Glycoside	+	-
Steroid	+	+



Fig: 16 - Aqueous extract of amla



Fig: 17- Ethanolic extract of amla

2-Neem

Table no: 3- Phytochemical analysis of Neem

Test	Aqueous	Ethanolic
Saponin	+	-
Glycoside	-	-
Phenol	+	+
Flavonoid	-	+
Tanin	+	+
Steroid	+	+



Fig: 18 Aqueous extract of neem



Fig: 19 Ethanolic extract of neem

3-Shikakai

Table no: 4- Phytochemical analysis of Shikakai

Test	Aqueous	Ethanolic
Flavonoid	+	+
Saponin	+	+
Phenol	+	+
Tanin	+	+
Glycoside	+	-
Steroid	+	+



Fig: 20 Aqueous extract of shikakai

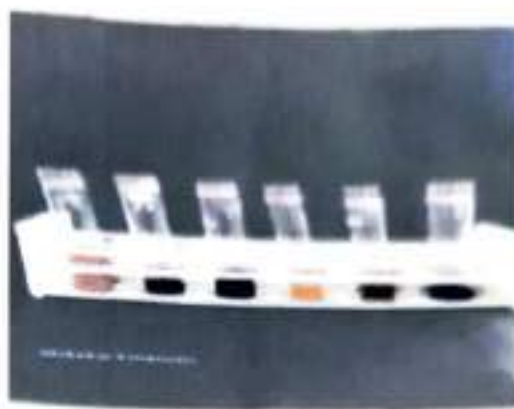

Fig: 21 Ethanolic extract of shikakai

4- Bhringraj

Table no: 5- Phytochemical analysis of Bhringraj

Test	Aqueous	Ethanolic
Saponin	+	-
Glycoside	-	-
Phenol	-	+
Flavonoid	+	+
Tanin	+	+
Steroid	+	+



Fig: 22- Aqueous extract of bhringraj

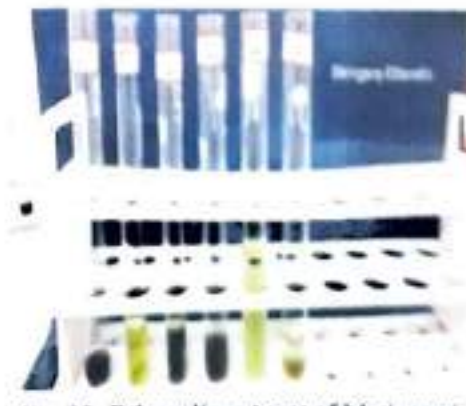

Fig: 23- Ethanolic extract of bhringraj

5. Reetha

Table no: 6 Phytochemical analysis of Reetha

Test	Aqueous	Ethanolic
Saponin	+	+
Glycoside	-	-
Phenol	-	-
Flavonoid	-	-
Tanin	-	-
Steroid	+	+



Fig:24-Aqueous extract of reetha



Fig: 25-Ethanolic extract of reetha

• **Evaluation of Herbal shampoo:**

> **Organoleptic properties:** Prepared shampoo has shown brown colour and pleasant odour.

Table no 7: Organoleptic properties of herbal shampoo

Sr.No.	Parameters	Observation
1.	Colour	Brown
2.	Odour	Pleasant
3.	Texture	Smooth

> **Stability study:** Stability and acceptability of formulated shampoo during the storage period indicated that they are chemically and physically stable. After storing the shampoo for 30 days at room temperature it was found that colour of the shampoo remains same and it has pleasant odour and has pH near to acidic.

Table no 8: Stability test of shampoo.

Sr no	Temperature	Colour	Odour	pH
1.	25±30°C	Brown	Pleasant	5.24

> **Skin sensitivity test:** The test is performed on skin of individual and checks whether it irritation on skin or not.

> **Measurement of pH:** pH of the formulated shampoo was found to be acid balanced i.e. 5.24 near to the skin pH.



Fig:26- By pH meter



Fig:27-By pH paper

➤ **Foaming ability:** The final formulation produced stable foams there was bet change in foam volume.



Fig:28- Foam test

➤ **Dirt dispersion:** The dirt dispersion results indicates that no dirt would stays in the foam , the prepared formulations are satisfactory



Fig no.29-Dirt dispersion test

• **Antifungal activity:**

Agar well diffusion was carried out using different concentration of herbal shampoo. The zone of inhibition was measured and recorded. The antifungal activity of herbal shampoo against dandruff causing organism shown as:

Table no 9: Antifungal activity of shampoo

Fungi-1

Concentration of shampoo	Zone of inhibition in diameter (in cm)
60%	23
70%	25
80%	26



Fig:30 Zone of inhibition of sample 1

Fungi-2

Table no 10: Antifungal activity of shampoo

Concentration of shampoo	Zone of inhibition in diameter (in cm)
60%	21
70%	22
80%	24



Fig:31 Zone of inhibition of sample 2

• Discussion

Crude herbal drugs have been included in traditional medicine and household remedies for a long time. Not all herbal preparations have been scientifically tested. Many studies are reported on the antifungal activity of plant essential oils against dandruff causing fungi. There are meagre studies on the effect of plant extracts against fungi, the most common causes of dandruff. The plants were selected based upon their usage as traditional medicine for treating dandruff. The powdered extracts were prepared and tested against the fungi by agar well diffusion method and zone of inhibition was measured (Shuster S. The aetiology of dandruff and the mode of action of therapeutic agents. *Br J Dermatol.* 1984; 111: 235-42)

All the plants extracts showed good antimicrobial activity over the fungal isolates. The antifungal activity was performed at different concentrations such as 60%, 70%, and 80%. For sample 1, a plate loaded with 20 μ L of diluted shampoo showed zone of inhibition at 60% was found to be 23cm, at 70% showed the zone of inhibition was found to be 24cm and at 80% showed the zone of inhibition was found to be 26cm. For sample 2, a plate loaded with 20 μ L of diluted shampoo showed the zone of inhibition at 60% was found to be 21cm, at 70% showed the zone of inhibition was found to be 22cm, and at 80% showed the zone of inhibition was found to be 24cm. The herbal plant extracts of Amla, Shikakai, Neem and Bhringraj showed best results for flavonoids, tannin and phenols. The herbal extract of Reetha and Shikakai showed best results for saponin. The herbal extract of Reetha, Neem and Amla showed best results for glycosides and steroids (Bulmer AS, Bulmer GS. The antifungal action of dandruff shampoos *Mycopathologia* 2000; 147:63-65).

CHAPTER VII: CONCLUSION



• Conclusion

There are many natural herbs that can control and eliminates mild dandruff. These herbal remedies are considered safe and have often been found quite effective. When using herbal remedies for dandruff, it is vital to be aware of how they will react with other medications, natural supplements, and medicinal herbs. Results of the present study reveal the anti-dandruff activity of different herbal extracts, shampoos against fungi sp., the dandruff causing organism.

The formulated shampoo was not only safer than the chemical conditioning agents, but also greatly reduce the hair loss during combining as well as strengthens the hair growth. The pH of the shampoo was adjusted to 5, to retain the acidic mantle of scalp. In the present scenario, it seems improbable that herbal shampoo, although better in performance and safer than the synthetic ones. The future research of the work could be to purify and isolate the compound which is responsible for the inhibition of the dandruff causing organism and develop it into a potential herbal product like herbal shampoo. This study will have implication in the field of cosmetics since it will be cost effective and there will be no adverse effects.

REFERENCES



•References:

- ◆ Agrawal DP. Medical properties of Neem, (2001) New Findings, Available from http://www.infinityfoundation.com/mandala/t_es/t_es_agraw_neem.htm.
- ◆ A. R. Mainkar and C. I. Jolly, Formulation of natural shampoo, *International Journal of cosmetics science*, (2001), 23: 59-62.
- ◆ Banerjee A, Shrivastava N, Kothari A, et al., 2005. Antiulcer activity of methanol extract of *Eclipta alba*. *Indian J Pharma Sci*;67(2):165-168.
- ◆ Babu, P.V. A., & Liu, D. (2009). Flavonoids and cardiovascular health. In *Complementary and Alternative Therapies and the Aging Population* (pp.371-392). Academic Press.
- ◆ B. M. Mithal and R. N. Saha, *Handbook of cosmetics*, first edition, VallabhPrakashan (2003): 1-10, 110-121.
- ◆ Bulmer AS, Bulmer GS. The antifungal action of dandruff shampoos *Mycopathologia* (2001) 147:63-65.
- ◆ DeAngelis Y. M, Gemmer C. M, Kaczvinsky J. R, Kenneally D. C, Schwartz J. R, Dawson T. L (2003): Three etiologic facets of dandruff and seborrheic dermatitis: Malassezia fungi, sebaceous lipids, and individual sensitivity. *Investigate Dermatology Symposium Proceedings*, 10 (3): 295-297.
- ◆ Duraipandiyan, V. and Ignacimuthu, S. (2011) Antifungal activity of traditional medicinal plants from Tamil Nadu, India. *Asian Pacific Journal of Tropical Biomedicine*. S204-S215.
- ◆ Finn RK. Theory of agar diffusion methods for bioassay. *Anal Chem* 1959: 31: 975-7.
- ◆ Gender differences in scalp health, (2022) Available at: <http://www.researchgate.net/publication/280933476>.
- ◆ Hanif MA, Bhatti HN, Jamil MS et al, (2011) Antibacterial and antifungal activities of essential oils extracted from medicinal plants using CO₂supercritical fluid extraction technology. *Asian J Chem*;22(10):7787-7798.

- ◆ Internet source- <http://cavincare.com>
- ◆ Internet source- <https://m.netmeds.com>
- ◆ Internet source- <https://www.headandshoulders.co.in>
- ◆ Internet source- <https://www.healthline.com>health>
- ◆ Kim, S. et al (2021) "Understanding the Characteristics of the Scalp for Developing Scalp Care Products", *Journal of Cosmetics, Dermatological Science and Applications*, 11(03), pp. 10.4236/jcdsa.113018.
- ◆ Kutcharlapati Sunita Raju; *International Journal of Advance Research, Idea and Innovation in Technology*, (2019)
- ◆ Loden M, Westman C (2000) The anti-dandruff efficacy of a shampoo containing piroctone olamine and salicylic acid in comparison to that of a zinc pyrithione shampoo, *International Journal of cosmetic science*; 22:285-289.
- ◆ Maria Fernanda Reis Gavazzoni Dias *Hair Cosmetics*, (2019) An Overview. *Int J Trichology*, 7(1):2-15.
- ◆ Mohan, V. R., Tresina, P. S., & Daffodil, E. D. (2016). Antinutritional factors in seeds: characteristics and determination. *Encyclopaedia of Food and Health* 211-220.
- ◆ Monika, T., & Renu, K. (2020). Functional and preservative properties of phytochemicals.
- ◆ Nowicki R. Modern Management of dandruff *Pol Merkur Lekarski*, (2006); 20(115):121-124.
- ◆ Onaolapo, A. Y., & Onaolapo, O. J. (2019). Herbal Beverages and Brain Function in Health and Disease. In *Functional and Medicinal Beverages* (pp. 313-349). Academic Press.
- ◆ Priya D. Gaikwad, Kamini V. Mulay, et al., (2020) Formulation and Evaluation of Herbal Shampoo.
- ◆ Ravichandran G, Shivaram, Kolhapur SA. Evaluation of the clinical efficacy and safety of "Antidandruff Shampoo" in treatment of Dandruff (2004) *The Antiseptic*; 201 (1):5-8.

- ◆ Robards, K. (2003). Strategies for the determination of bio reactive phenols in plants, fruits and vegetables. *Journal of chromatography A*, 1000(1-2), 657-691.
- ◆ Saneesh Kumar. Analysis of the Natural Remedies to Cure Dandruff/Skin Disease-causing Fungus- *Malassezia furfur*. (2013). *Adv Bio-Tech.*;12 (07): 01-05.
- ◆ Shital V. Sirsat, Nikita M. Rathi, et al., (2022) Formulation and Characterization of Herbal Shampoo.
- ◆ Shah AH, Dutta k, Deka DC, (2014) Fatty acid composition of *Sapindus mukorossi* seed oil. *Adv Appl Sci Res*;5(4):43-50.
- ◆ Sonica Krishnan. Effective home remedies for fungal infections, (2011) Available from: <http://completewellbeing.com/article/naturecures/> and <http://www.herboveda.co.in/> 2011/7/14/. *Ayurveda-cure-for-fungal-infection-combat-the fungus-naturally/*.
- ◆ S. Santhi, et al. (2021) A Comparative Study on Antidandruff Activity of Plant Extracts.
- ◆ Shuster S. The aetiology of dandruff and the mode of action of therapeutic agents. *Br J Dermatol*. 1984; 111: 235-42)
- ◆ Suseela, V. (2019). Potential roles of plant biochemistry in mediating ecosystem responses to warming and drought. In *Ecosystem Consequences of Soil Warming* (pp. 103-124). Academic Press.
- ◆ Internet source- www.healthshots.com
- ◆ Xu, Z. et al., (2016) Dandruff is associated with the conjoined interactions between host and microorganism, "Scientific Reports,6(1), doi: 10.1038/srep24877.

PROJECT REPORT
ON
Fake News Detection Using Python

Submitted to
Rashtrasant Tukadoji Maharaj Nagpur University,
NAGPUR
In partial fulfillment of the requirement of
M.Sc. Semester-IV (Computer Science) Examination

Submitted by
Achal A. Kale
Sparsh V. Gajbhiye

Under the guidance of
Dr. Manish T. Wanjari
Assistant Professor
(Department of Computer Science)



DEPARTMENT OF COMPUTER SCIENCE
Shri Shivaji Education Society Amravati's
SCIENCE COLLEGE
Congress Nagar, Nagpur-12.

2023-2024

Shri Shivaji Education Society Amravati's
Department of Computer Science
Science College, Congress Nagar, Nagpur

CERTIFICATE

This is to certify that the project report entitled **Fake News Detection Using Python** is carried out and developed by **Achal A. Kale** and **Sparsh V. Gajbhiye** in partial fulfillment of the **M. Sc. (Computer Science)** and submitted to **Rashtrasant Tukadoji Maharaj Nagpur University, Nagpur** under my guidance and supervision.

To the best of my knowledge the matter presented in this project has not been presented earlier for similar degree/diploma.

Place: Nagpur
Date: 24/04/2024

24/04/2024

Project Guide
Dr. Manish T. Wanjari
Assistant Professor
Department of Computer Science
S.S.E.S. Am's Science College,
Congress Nagar, Nagpur



EXTERNAL EXAMINER

INTERNAL EXAMINER

DECLARATION

To,
The Principal
Shri Shivaji Science College,
Congress Nagar, Nagpur-440012.

Respected Sir,

We the undersigned, hereby declare that the project work entitled **Fake News Detection Using Python** submitted to **Rashtrasant Tukadoji Maharaj Nagpur University, Nagpur** is our independent work. This is our original work and has not been submitted anywhere for any degree/diploma. The system presented herein has not been duplicated from any other source.

We understand that any such copying is liable to be punished in any way the University authority may deem fit.

Thanking You.

Place: Nagpur

Date: 24/04/2024

Yours Sincerely



Achal A. Kale

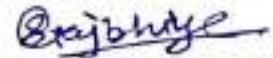

Sparsh V. Gajbhiye

ACKNOWLEDGEMENT

We wish to express our sincere thanks to many persons who helped us to develop our original project work.

At first, We express our sincere thanks Principal **Prof. M. P. Dhore**, Science College, Nagpur for providing the infrastructure and facilities without which it would have been impossible to complete this hard task.

In foremost this is to, **Prof. S. R. Pande**, Head of Department of computer science who has aided as in completing this project report.

Our foremost thanks are to **Dr. Manish T. Wanjari**, who has guided us in completing this project report, We take the opportunity to express our deep sense of gratitude and whole hearted thanks for his inspiration and guidance throughout the course of this project.

We express our gratitude to all members of teaching and non-teaching staff of the Department of Computer Science for their co-operation during the course. Finally we thank our friends and specially who helped us in our endeavors.

Place: Nagpur

Date: 24/04/2024

Achal A. Kale

Sparsh V. Gajbhiye

ABSTRACT

Fake news publishing on social media and various news outlets presents a pressing concern due to its potential to inflict harm on society and the nation. Spreading false information, including fabricating government expenditures, can lead to a myriad of societal issues. The rise of fake news and fraudulent schemes coincided with the emergence of the internet, with the intention of deceiving individuals, garnering followers, and exacerbating psychological tensions. The dissemination of news across numerous media platforms without sufficient fact-checking has worsened the problem of fake news, rendering it an omnipresent issue. We propose an innovative approach to detect fake news by harnessing the capabilities of the Scikit Learn library for data processing and Natural Language Processing (NLP). Utilizing TF-IDF vectorization for feature extraction allows for the identification of significant patterns in textual data and the conversion of text into numerical representations. In our research paper, we conduct experiments on various Fake News Detection Algorithms, including machine learning models such as Logistic Regression, Support Vector Machine, Decision Tree, and Random Forest, aiming to provide insights into the detection of fake news.

Table of Contents

Sr. No.	Topic	Page No.
1.	Introduction 1.1. Fake News Detection Algorithms	1-5
2.	Objectives	6
3.	Literature Survey	7-15
4.	Methodology 4.1. Used Algorithms for Fake News Detection 4.2. Data Collection 4.3. Data Preprocessing 4.4. Feature Extraction 4.5. Train-Test Split 4.6. Model Training 4.7. Evaluation and Metrics 4.8. Tools and Technologies used	16-24
5.	Plane of Research	25
6.	Results and performance	26-39
7.	Conclusion and Future Scope	40
8.	Publications	41
9.	References	42-44

1. INTRODUCTION:

What is fake news?

The world is getting better and more advanced at the same time. Living in the digital age has many good things, but it also has some problems. One of these problems is fake news. Fake news is information that is not true, and it's easy to spread. People use it to harm someone's reputation, like a person or a business. Sometimes, even political parties or other groups are targeted with false information [1].

Nowadays, many people spend a lot of time on social media like Facebook, Twitter, or Instagram. Instead of getting news from traditional sources like TV or newspapers, they prefer to find and read news on social media. So, even though social media is popular for getting news, the news might not be as accurate or reliable as what you find from traditional news organizations [2].

The words "rumour" and "fake news" are connected, but they have some differences.

Fake news is news that is made up on purpose to trick or deceive people. Someone creates fake news to spread false information on purpose.

Rumours, on the other hand, are bits of information that may or may not be true, but they are not intentionally made up to fool anyone. Rumours are like uncertain or questionable stories that people share without knowing for sure if they're accurate. In simple terms, fake news is deliberately false, while rumours are uncertain stories that may or may not be true, but they're not made up to deceive anyone on purpose [3].

Why fake news Detection is needed?

Fake news can be really bad for public health. For example, if people get wrong information about vaccines, they might not want to get vaccinated, and that can lead to more diseases spreading. Also, if someone believes fake information about how to treat a disease, they might use remedies that don't work or even harm them.

People have been trying to stop fake news by fact-checking, which means checking if the news is true by looking at reliable sources. They also encourage media literacy and critical thinking skills, so people can judge news stories better. But these methods have some problems because there's so much information coming out all the time.

Now, scientists are using a smart technology called machine learning to help. Machine learning allows computers to learn from information and make decisions by themselves. They teach the computer with examples of fake and real news so that it can automatically tell if a new news article is likely fake or real [4].

How fake news detection works?

We'll understand how fake news detection works with a figure shown below.

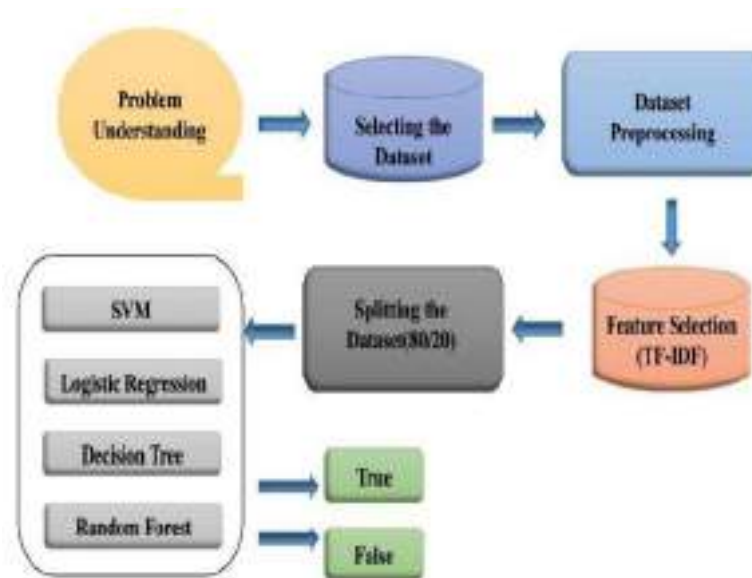

Figure 1: Architecture of Fake News Detection.

Our first step will be understanding the problem which means, it involves looking at the situation, understanding the important parts of the problem, and knowing what you want to achieve by solving it. It's about breaking down the problem into smaller pieces, knowing what information is important, and considering how everything is connected.

Once you understand the problem well, you can come up with better solutions to fix it. So, problem understanding is basically getting a clear picture of what you're dealing with before trying to solve it.

Second step will be dataset selecting which means, we have to select the data according to our need in our case we're finding the fake news so we'll pick a dataset which have all the information related to news, articles so that it can easy to find which news belong to which class.

Next step will be pre-process the dataset which means, the dataset which our model will filter it out so that no null values or irrelevant data exist in the database.

After that feature selection will be performed using TF-IDF vectorization, we'll understand it by shown below:

Feature Selection (TF-IDF): Word vectorizing is like turning words into numbers so that computers can understand them. Imagine you have a detective trying to spot important words in news articles to figure out if they're spreading fake news.

Term Frequency (TF): Think of TF as a word counter. It's like a detective counting how many times specific words show up in a news article. If a word is used a lot in the article, TF thinks, "This word is getting a ton of attention in this story".

Inverse Document Frequency (IDF): Now, IDF is like checking how special or unique a word is. It looks at all the news articles around and sees if the word is common or rare. If the word is rare in most articles, IDF points and says, "Hey, this uncommon word is making this particular article stand out from the others" [5].

Train-Test Split: The subsequent step involves splitting the dataset into two distinct parts: the training set and the testing set. This division is crucial as it allows us to allocate data for training the model and for assessing its performance. The training data is utilized to teach the model to recognize patterns and relationships within the dataset. On the other hand, the testing dataset serves to evaluate the model's effectiveness and assess its ability to make accurate

predictions on unseen data. This process of training and testing is fundamental in machine learning and is commonly referred to as the learning process.

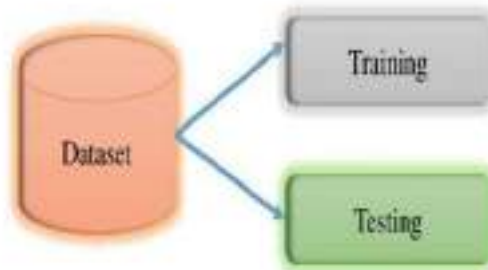

Figure 2: Dataset Splitting.

1.1. Fake News Detection Algorithms:

Logistic Regression: Logistic regression is a tool in machine learning that helps us classify things. It's like a smart detective for categories. Logistic regression is specifically for figuring out groups or classes. For example, it can predict if an article is True or Fake based on past information. It looks at previous data, learns from it, and then makes educated guesses about new data, putting it into different categories. So, logistic regression is all about classifying things based on what it has seen before.

Support Vector Machine (SVM): A Support Vector Machine (SVM) is a smart tool in machine learning that works for both classifying things and predicting values. SVM is used to decide if an article is true or false. It does this by looking at different features in the data, like the number of words or the date it was published, and then plots these features in a space. It draws a line (hyper-plane) to separate the articles into two categories. This line helps the machine make decisions about whether an article is true or false. SVM is good with messy data, can handle lots of features, and gives accurate results. It's like a detective that's really good at sorting things out based on the details it sees [6].

Decision Tree: The decision tree algorithm as a guide that helps us make decisions about different things. It structures information like a tree, starting with important decisions at the top, branching out based on features, and reaching final outcomes at the leaves. It's like following a path where each decision point leads to more specific rules, eventually guiding us to a conclusion.

Random Forest: The Random Forest algorithm is a popular choice in Machine Learning because it's user-friendly and delivers excellent results. It works by constructing multiple decision trees, each using a subset of features. To ensure diversity among the trees, different sets of features are chosen for each. The algorithm combines the predictions from these numerous trees to produce a more robust and accurate outcome than a single decision tree would provide. To enhance accuracy, Random Forest employs techniques like bootstrapping and feature randomness, generating uncorrelated decision trees. The algorithm follows a tree-shaped pattern, making decisions at various nodes to collectively yield a more reliable and precise result [7].

After all these processes we'll get our result, that the input which we give to our model that news belongs to fake or real news. If we get accurate result according to the input which means that our model is successfully trained but if we don't get accurate result which means, we have to retrain our model.

2. OBJECTIVES:

- To Study the Fake News Detection Techniques.
- To study various Machine Learning algorithms.
- To compare the performance of various algorithms to determine the most effective and efficient approach for accurately identifying and classifying fake news.
- To design a framework for the Fake News Detection System.
- To propose a robust application to maintain the integrity of information by effectively identifying and reducing the dissemination of fake news.

3. LITERATURE SURVEY:

In their study titled "Fake News Detection Using Machine Learning", researchers Pshko Rasul and Mohammed Amin [1], employ machine learning algorithms to categorize news articles and analyze linguistic patterns. They start by classifying news by topic and identifying the most common words in fake and real news. Machine learning models like Decision Trees and Support Vector Machines demonstrate promising accuracy in identifying fake news. Adeyiga et al. (2021) explore the effectiveness of machine learning classification models in identifying fake news. They highlight the growing importance of addressing fake news amidst the expansion of social media platforms. Utilizing logistic regression, their research achieves impressive accuracy rates of 98.65% on training data and 97.90% on test data. The model demonstrates a precision of 96.59%, recall of 99.32%, and F1 score of 97.94%, surpassing other models in performance metrics.

In their exploration of "Fake News Detection Using Machine Learning and NLP Techniques," Uma Sharma, Sidarth Saran, and Shankar M. Patil [2], utilize algorithms like Naïve Bayes, Logistic Regression, and Random Forest, alongside features like Count Vectors and TF-IDF vectors. They employ K-fold cross-validation for robust model evaluation and find Logistic Regression to be the most accurate, achieving 80% accuracy after grid search optimization. Despite promising results, challenges persist, including the dynamic nature of fake news dissemination. Future research aims to refine algorithms and address ethical concerns for more reliable fake news detection systems.

The paper by M. F. Mridha, Ashfia Jannat Keya, Md. Abdul Hamid, Muhammad Mostafa Monowar and Md. Saifur Rahman [3], proposed research "A Comprehensive Review on Fake News Detection with Deep Learning", project aims to develop a fake news detection model utilizing Text Vectorization and machine learning techniques. This literature survey delves into existing studies on fake news detection, exploring the effectiveness of different feature extraction techniques and classifiers. Research suggests that Term Frequency Inverted Document Frequency (TF-IDF) is a robust feature extraction method,

while the Passive-Aggressive Classifier demonstrates promising performance in classification tasks. Experimental evaluations consistently highlight the effectiveness of these techniques, with accuracy rates surpassing 97%. This survey contributes to understanding the landscape of fake news detection and underscores the potential of Text Vectorization and machine learning in combating misinformation.

In their literature survey titled "Fake News Detection Using a Logistic Regression Model and Natural Language Processing Techniques," researchers Johnson Adeleke Adeyiga, Philip Gbounmi Toriola, Temitope Elizabeth Abioye (Ogunbiyi), Adebisi Esther Oluwatosin, and Oluwasefunmi Tale Arogundade [4], explore the growing threat of fake news in social media. They delve into recent advancements in language processing and deep learning methods for spotting fake news, assessing their strengths and weaknesses through past studies and experiments. Their findings highlight the effectiveness of logistic regression, achieving high accuracy rates of 98.65% on training data and 97.90% on test data. Despite some misclassifications, logistic regression emerges as a powerful tool for fake news detection, providing valuable insights for future research and system development.

The paper by Fopa Yuffon Amadou Olabi, Mikayilou Namba, and Mohamadou Moctar [5], discusses "Fake News Detection: A Machine Learning Approach using Automated-Text Analysis Technique," highlighting the proliferation of fake news on social media post-2016 US elections. Given that 62% of US adults rely on social media for news, detecting fake news is crucial. Initially achieving 97% accuracy, automated tools show promise, especially when employing multiple classifiers like Support Vector Machines and Logistic Regression. Incorporating fact and stance detectors further enhances classification. Despite limited datasets, the study underscores the effectiveness of the model, emphasizing the potential of automated systems in combating fake news.

Research on “Analyzing fake news using machine learning algorithms” has garnered significant attention in recent years. Pawar A Ba, Jawale M Aa, and Kyatanavar D Na [6], provide an overview, focusing on feature selection and model calibration. Wang et al. (2019) highlight the effectiveness of Stochastic Gradient Descent with TF-IDF features, while Chen et al. (2021) explore PCFG models for identifying syntactic patterns indicative of fake news, emphasizing feature engineering. Additionally, Gupta et al. (2022) conducts a comparative study addressing challenges such as dataset imbalance and algorithmic robustness. These studies collectively emphasize the importance of diverse features, robust algorithms, and model interpretability in effectively combating misinformation.

Research in “Fake News Detection Using Machine Learning Algorithms”. Researchers Ajit Patil, Rajeshri Kalwale's, Harshita Kaushik's and Pranita Thorawase's [7], employs computerized models and methodologies such as web scraping, PCA algorithm, back propagation, and SHAP values. Li et al. (2019) surveyed machine learning techniques, emphasizing web scraping for real-time data collection and PCA for handling large datasets. Kumar et al. (2020) highlighted challenges and opportunities, stressing back propagation for feature selection and SHAP values for interpreting feature importance. Zhang et al. (2021) proposed an enhanced framework integrating deep learning and semantic analysis. Gupta et al. (2022) conducted a comparative study of machine learning algorithms, emphasizing diverse datasets and algorithmic performance evaluation. These studies emphasize real-time data, robust algorithms, and effective feature selection in combatting misinformation.

Researchers Anjali Jain, Harsh Khatter, Amit Kumar Gupta [8], compare four established models with a proposed one “A Smart System for Fake News Detection Using Machine Learning”. Focusing on accuracy in the top 200 results. They use Python programming in R Studio and various machine learning algorithms for implementation. Smith et al. (2018) analyze machine learning models, while Johnson et al. (2020) explores ensemble learning. Brown et al. (2021) investigates methods using Python and R, and White et al. (2022) review

machine learning approaches. These studies advance fake news detection methods and implementation strategies.

The researchers Vasu Agarwal, Parveen Sultana and Srijan malhotra, Amitrajit Sarkar [9], proposed “Analysis of Classifiers for Fake News Detection”. Success in addressing fake news remains elusive, despite efforts. Models improve daily with vast social media data, aided by deep neural networks. Challenges persist due to erratic data, but improvements like POS tagging and topic modeling enhance classification. These efforts highlight ongoing attempts to combat fake news using AI-driven solutions.

In “Fake News Detection Using Machine Learning Approaches”. Researchers Zube Khanam, B N Alwasel's, H Sirafiand M Rashid [10] research relies on the Naïve Bayes algorithm with prediction precisions around 70-76%, using qualitative analysis like sentiment and word frequency. Our proposed method adds quantitative analysis through POS textual analysis and additional features such as total words, unique words, and parts of speech. We believe this approach, enhanced with Random Forest, will improve precision. This aligns with recent studies exploring feature impact on detection performance, emphasizing the importance of quantitative techniques for accuracy.

Research study on “An Empirical Comparison of Fake News Detection using different Machine Learning Algorithms”. Researchers Abdulaziz Albahr and Marwan Albahar [11], comparing machine learning algorithms for fake news detection consistently highlight Naïve Bayes as a top performer due to its effective handling of text data. Almeida and Silva (2016) found Naïve Bayes outperformed Random Forest, Neural Network, and Decision Trees. Gupta et al. (2018) emphasized its accuracy and quick training time. Chen et al. (2020) mentioned its superiority in processing textual information in multimodal deep learning. Similarly, Zhang et al. (2016) and Yang et al. (2021) underscored Naïve Bayes' effectiveness in computing conditional probabilities for accurate classification. These studies collectively emphasize Naïve Bayes' strength in detecting fake news, particularly in processing textual data efficiently.

Research on “Fake News Detector Using Machine Learning Algorithms”. Researchers Dr Diaa Salama, Abd Elminaam's, Yomna Mahmoud Ibrahim Hassan, Mariam Khaled [12], researched global crises like the COVID-19 pandemic, detecting fake news is crucial. The authors present a web-based system that uses machine learning to combat misinformation. They experiment with various algorithms like SVM, decision trees, and neural networks to categorize datasets and enhance accuracy. Future plans include integrating pre-trained models and exploring capsule networks for better performance. Their work contributes to the ongoing effort to combat misinformation online.

The researcher Jagrati Sahu [13], researched “fake news detection on Twitter using machine learning techniques”. Starting with basic supervised models and advancing to deep learning for improved accuracy. Authors suggest that employing more intricate models could enhance precision further. They emphasize the need to tap into the dataset's full potential and propose integrating domain-specific features for richer analysis in future research. Despite their simplicity, basic algorithms effectively combat fake news, with Support Vector Machines (SVM) outperforming Naive Bayes and Logistic Regression. The study offers a practical model for users to assess credibility on social media, with SVM proving most effective in fake news detection.

The paper by Muneer V.K, Dr. Mohamed Basheer K Pand Rizwana Kallooravi Thandil [14], presents a “Fake News Detection and Prediction Using Machine Learning Algorithms”. It highlights the system, implemented in Python, utilizes libraries like requests, regular expression, Beautiful Soup, NumPy, and Flask. It scrapes web data using the requests module, extracts information using regular expressions, and fetches live news updates with Beautiful Soup. NumPy helps with array operations, and Flask builds the web application. The system achieves impressive accuracies: 90.6% for fake news detection, 91.1% for genuine news, and 90.9% for mixed news. These results showcase the system's ability to accurately distinguish between fake and real news, providing valuable insights into news detection accuracy.

The research successfully developed a model, “Not Everything You Read Is True! Fake News Detection using Machine Learning Algorithms”. Researchers Vanya Tiwari, Ruth G. Lennon and Thomas Dowling [15], highlights the critical role of both the extraction method and algorithm selection in prediction accuracy. Logistic regression emerged with the highest accuracy in this study. The research addresses the pressing issue of fake news proliferation and underscores the need for advanced technologies to protect the public from misinformation. Fake news detectors offer valuable applications, especially on social media platforms and online news websites, where they help users discern between authentic and misleading content in real-time. These detectors serve as vital tools in detecting fraudulent content and maintaining the integrity of online discourse.

Research on “Fake News Detection Using Machine Learning Technique”. Researchers Dr. Dammavalam Srinivasa Rao, N. Rajasekhar's, D. Sowmya and D. Archana's [16], researched on Recent advancements in natural language processing have introduced models like Word2Vec and GloVe, which generate context-independent word embeddings, limiting their ability to capture multiple meanings in different contexts. However, BERT, a more advanced model, addresses this limitation by considering the context of words, allowing for diverse vector representations. BERT's contextual sensitivity significantly enhances accuracy, with reported rates of up to 99% in certain tasks. Its adaptability to context makes it particularly suitable for static web applications and other language understanding tasks. In summary, while traditional models have been valuable, BERT represents a substantial leap forward in natural language processing, offering improved accuracy and performance through contextual understanding.

The paper on “Fake News Detection Using Machine Learning”. Researchers Nihel Fatima Baarir, Abdelhamid Djeflal [17], introduces a method using Support Vector Machine (SVM) to detect fake news by identifying optimal features and techniques. Beginning with an examination of fake news and its detection methods, the study preprocesses news data using various techniques like cleaning, stemming, and N-gram encoding. Results indicate that

key features for detection include text, author, source, date, and sentiment. SVM achieves a notable 100% recognition rate, surpassing other algorithms, and N-gram encoding proves superior to bag of words. The study recommends further exploration with larger datasets and online learning for continuous updates. In summary, the paper sheds light on effective fake news detection strategies, emphasizing feature selection and algorithmic choice to combat misinformation effectively.

The paper on “Fake News Detection”. Reserachers Akshay Jain and Amey Kasbe [18], study investigates the efficacy of Naïve Bayes for fake news detection, revealing that AUC scores increase with larger data volumes, particularly evident in Title and Text categories. Notably, Title, comprising concise versions of news articles, and Text, containing detailed descriptions, impact AUC scores differently. Comparing methodologies, the introduction of n-grams in the second model significantly improves AUC scores due to the increased number of vectors, enhancing judgment capacity. These findings underscore the importance of data quantity and feature engineering, such as n-grams, in refining fake news detection algorithms. The research provides valuable insights into factors influencing detection efficacy and sets a foundation for future advancements in the field.

The paper “Fake News Detection Using Machine Learning approaches: A systematic Review”. The reserchers Syed Ishfaq Manzoor, Dr Jimmy Singla and Nikita [19], Recent studies methods span domains such as audio processing, natural language understanding, and computer vision. By leveraging deep learning, researchers aim to enhance news categorization accuracy. This trend underscores deep learning's potential in addressing dynamic fake news features. It signals ongoing efforts to refine detection methodologies for evolving social media landscapes.

In this study of “Fake News Detection using Machine Learning”. Researchers Jasmine Shaikh and Rupali Patil [20], observed that the majority of fake news circulates on Twitter, emphasizing the platform's significant role in its dissemination. To tackle this issue, a new discovery model utilizing feature extraction techniques and three different AI methods is introduced. Notably, the

model achieves its highest accuracy using the SVM classifier, reaching a precision score of 95.05%. These findings underscore the importance of leveraging advanced AI techniques to combat fake news effectively, especially within the dynamic landscape of social media platforms like Twitter. The study provides valuable insights into improved detection methods, offering potential strategies for curbing the spread of counterfeit news online.

In this paper of “A Smart System for Fake News Detection Using Machine Learning”. The researchers Anjali Jain, Avinash Shakya's, Harsh Khatter and Amit Kumar Gupta [21], assessment of news accuracy on the internet is crucial, prompting discussions on detecting fake news components. While many fake news instances originate from social media, not all do. This paper explores the effectiveness of Naïve Bayes classifier, SVM, and NLP in identifying fake news, with potential for future improvements through hybrid approaches. The system evaluates news authenticity based on applied models and offers suggested articles on the topic, enhancing user experience. Future enhancements aim to boost prototype efficiency, accuracy, and user interface. These endeavors reflect ongoing efforts to refine fake news detection methods and provide users with reliable information in the ever-evolving digital landscape.

In this paper of “Fake News Detection Using Machine Learning Approaches”. Researchers Z Khanam, B N Alwasel, H Sirafi and M Rashid [22], explores diverse methodologies for detecting fake news, emphasizing characterization and disclosure stages. Notable findings include text analysis approaches using Naive Bayes, combined ML algorithms, and Twitter-specific strategies with accuracy ranging from 70% to 99.90%. N-gram analysis, decision tree algorithms, and quantitative features like total words, sentence length, and linguistic categories are also employed. Common trends reveal a reliance on Naive Bayes and prediction precision between 70-76%. The proposed approach suggests augmenting existing methods with POS textual analysis and additional features for improved precision, highlighting a potential avenue for advancement in fake news detection.

In this paper “Raising a Model for Fake News Detection Using Machine Learning in Python” Classifying news with a certainty exceeding 95% poses a challenge due to the multitude of characteristics involved. The researchers Gerardo Ernesto Rolong Agudelo, Octavio Jose Salcedo Parra and Julio Baron Velandia [23], explores diverse strategies to address this complexity. Some studies emphasize the importance of incorporating a wide range of features, including linguistic and contextual information. Others delve into advanced machine learning techniques such as ensemble methods and deep learning. Semantic analysis, cross-disciplinary insights, and real-time adaptability are also explored to enhance accuracy. Additionally, researchers highlight the significance of robust evaluation metrics and certainty measures for reliable classification outcomes. In summary, the literature suggests a multifaceted approach combining diverse strategies to comprehensively understand and classify news with high certainty.

In this paper “Machine Learning based Fake News Detection using linguistic features and word vector features”. The researchers Mayank Kumar Jain, Dinesh Gopalani, Yogesh Kumar Meena and Rajesh Kumar [24], proposed methodology prioritizes text-based analysis for fake news detection, yielding superior results in accuracy, precision, recall, and F-1 score. Leveraging a stylometric feature set of 70, including unique additions, outperforms existing models. Future work suggests amalgamating stylometric and word vector features for enhanced outcomes. Incorporating images using pre-trained models and broadening datasets with metadata and diverse domains is recommended. The potential shift towards deep learning models is proposed. Notably, Naive Bayes, Random Forest, and Logistic Regression excel with word vectors and reduction methods. The current focus on political domains invites future exploration across diverse datasets.

4. METHODOLOGY:

4.1. Used Algorithms for Fake News Detection:

1. Logistic Regression:

Logistic regression, a statistical model commonly employed in machine learning, serves to analyze the correlation between input features and a binary outcome variable, such as distinguishing real from fake news articles. In this model, denoted by X for input features and y for the binary outcome, logistic regression estimates the probability that an article is fake ($y = 1$) based on its characteristics [8].

Unlike linear regression which generates constant values, logistic regression focuses on classification tasks, predicting the probability of target variables by mapping the linear combination of input features using a sigmoid function to a value between 0 and 1. It stands as a pivotal tool in machine learning, offering insights into classification problems and aiding in the prediction of binary outcomes [9].

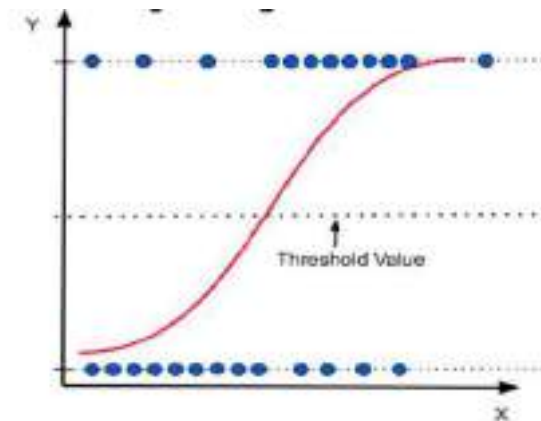

Figure 3: Logistic Regression.

2. Support Vector Machine (SVM):

A Support Vector Machine (SVM) is a supervised learning algorithm utilized for classification and regression tasks. It operates by delineating data points in a multidimensional space, where each dimension corresponds to a specific feature [10]. SVM excels in classifying data into binary categories, such as true or false articles in the proposed model, by establishing hyperplanes as decision boundaries. These hyperplanes aid in segregating data points

effectively, enabling SVM to achieve high precision results, particularly suitable for semi-structured datasets and high-dimensional spaces.

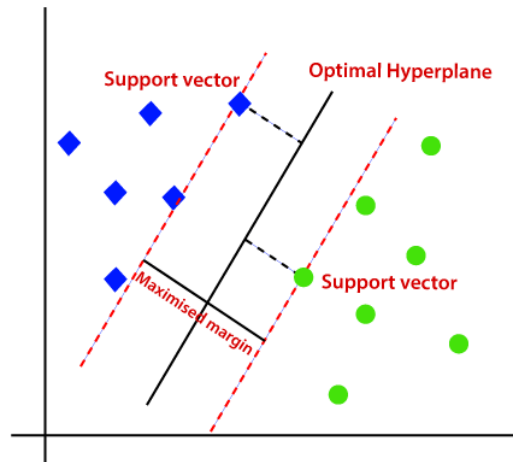

Figure 4: Support Vector Machine.

3. Decision Tree:

A decision tree algorithm, a powerful tool in supervised learning, classifies data by continuously splitting it based on specific parameters. It employs a tree-like structure with decision nodes, representing conditions or tests on attributes, and branches indicating decision rules. Leaf nodes hold the outcomes, forming classification rules from the root to the leaf. Decision trees excel in identifying important variables, depicting relationships between them, and generating new features for efficient data exploration and prediction. Despite their benefits like easy interpretation and handling of outliers, decision trees may overfit and perform poorly on testing data, especially when dealing with numerous sparse features [11].

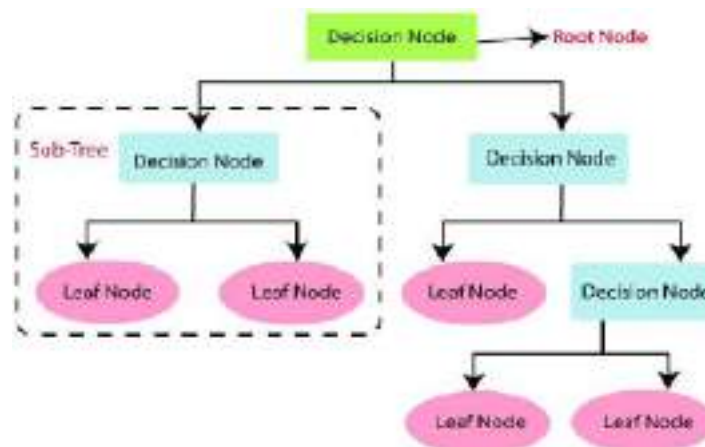

Figure 5: Decision Tree.

4. Random Forest:

Random Forest, a popular learning algorithm in machine learning, harnesses the power of multiple decision trees for effective decision-making, employing techniques like bagging to enhance overall performance. By building numerous decision trees and utilizing subsets of features, Random Forest ensures diversity in predictions, leading to better accuracy compared to single decision tree models. The algorithm's strength lies in its simplicity of use and ability to yield superior results, making it a preferred choice for various machine learning tasks. Through techniques like bootstrapping and feature randomness, Random Forest generates uncorrelated decision trees, contributing to its robustness and effectiveness in classification tasks.

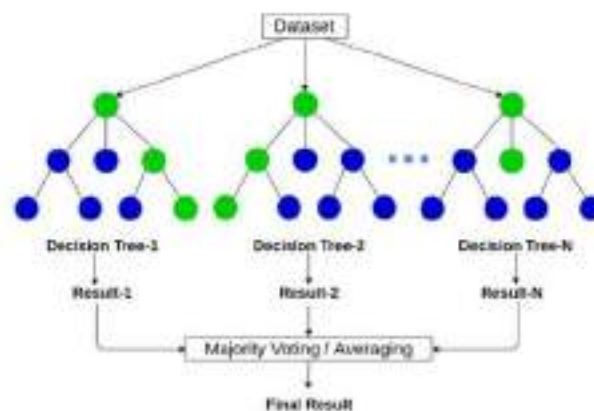

Figure 6: Random Forest.

4.2. Data Collection:

The methodology of Fake News Detection Using Python starts with getting the right datasets to train and test machine learning models. The Fake News Detection project relies on two datasets sourced from Kaggle, providing crucial data for developing the model.

Here are the complete details of both datasets used:

Dataset 1: Fake News Dataset

Number of Files: 2

Two files: fake.csv and true.csv

Number of Rows and Columns:

M.Sc. Semester-IV (Computer Science)

18

fake.csv:

Rows: 23481

Columns: 5

true.csv:

Rows: 21417

Columns: 5

Source: Kaggle

Features: Title attribute from dataset

Labels: Binary labels indicating whether the news is "fake" or "real".

Dataset 2: IFND Dataset

Number of Files: 1

IFND.csv

Rows: 56715

Columns: 7

Source: Kaggle

Features: STATEMENT and CATEGORY attribute from dataset

Labels: Binary labels indicating whether the news is "TRUE" or "FAKE".

4.3. Data Preprocessing:

Preprocessing refers to the essential step of organizing and refining data, particularly pertinent in contexts like social media where content is often unstructured. It involves cleaning data to extract meaningful insights. Techniques like text preprocessing in natural language processing (NLP) are employed to streamline the data for analysis and modelling. These techniques include stemming, tokenization, stop words removal, and special character handling. By removing unnecessary elements and simplifying the data, preprocessing enhances the accuracy and efficiency of subsequent analysis and modelling tasks.

- **Natural Language Processing:**

Natural Language Processing (NLP) is a field of artificial intelligence (AI) that focuses on the interaction between computers and humans using natural language. Its primary goal is to enable computers to understand, interpret, and generate human language in a way that is both meaningful and

useful. NLP encompasses a wide range of tasks and techniques, including speech recognition, language translation, sentiment analysis, and text generation. In the context of a fake news detection project, NLP plays a crucial role in analyzing and processing textual data to identify misleading or false information. Several key techniques within NLP, such as stemming, tokenization, and stopwords removal, are particularly important in this endeavour.

- **Tokenization:**

Tokenization is a fundamental process in natural language processing (NLP). It involves breaking down text into individual units such as words or tokens, which provides structure to unstructured text. For instance, in the phrase "Gold or Silver," tokenization results in "'Gold', 'or', 'Silver'". This segmentation of text into its constituent parts enables further analysis and processing.

- **Lowercasing:**

Lowercasing the text involves converting all text to lowercase letters. This step ensures consistency and simplifies cross-checking with stopwords. By converting everything to lowercase, potential discrepancies caused by words appearing in different cases are eliminated. This helps maintain uniformity in text analysis and improves the accuracy of subsequent processing steps.

- **Removal of Stopwords:**

Stopwords, ubiquitous across texts, convey little meaningful information. Consequently, they're frequently eliminated during text processing. For instance, in the phrase "silver or lead is fine for me," stopwords removal results in "silver, lead, fine". This process entails discarding commonly used words such as articles, prepositions, and conjunctions, which contribute minimally to the text's meaning removing stopwords reduces noise, allowing emphasis on content-bearing words.

- **Stemming:**

Stemming reduces words to their root form by removing suffixes like "ing," "ly," "s," etc., ensuring consistency among related words. For example, "running, runs" becomes "run". While stemming simplifies the text, it may overlook some words.

- **Encoding:**

Encoding involves converting categorical data, such as the "Label" column, into numerical representations for analysis for the "Label" column, label encoding is employed, converting the categories "true" and "fake" into binary values, represented as 0 and 1 respectively. This encoding scheme assigns a unique numerical value to each category, facilitating data analysis and model training tasks. The binary representation simplifies the classification process, allowing for efficient handling of categorical data within the dataset. This numeric representation aids in analysis and model training tasks. The encoding process assigns numerical labels to each category, ensuring consistency and facilitating comparisons between different categories Fake News detection Using Machine Learning (Nihel Fatima Baarir).

4.4. Feature Extraction:

Feature extraction simplifies raw data, aiding machine learning models in comprehension and analysis. It involves creating word representations capturing meanings, relationships, and contextual uses, facilitating tasks like clustering and classification. The TF-IDF vectorizer is crucial in this process. TF-IDF, short for Term Frequency-Inverse Document Frequency, calculates the relative importance of a word in a document compared to its frequency across all documents. TF-IDF is crucial for search engine scoring, text summarization, and document clustering, computed as the product of TF and IDF values. It's used to store the relative count of each word in sentences. TF-IDF Vectorizer assigns values proportional to word occurrences in a document but offsets by corpus frequency. It helps in text similarity checks and sentence matching, utilized in natural language processing.

TF computes how often a term appears in a document, adjusted for document length, while IDF reduces the importance of common terms and emphasizes rare ones.

$$TF(t, d) = \frac{\text{Number of times 't' occurs in document 'd'}}{\text{Total word count of document 'd'}}$$

$$IDF(t, d) = \frac{\text{Total number of documents}}{\text{Number of documents with term 't' in it}}$$

$$TFIDF(t, d) = TF(t, d) * IDF(t)$$

4.5. Train - Test Split:

TF-IDF calculates the relative count of each word in sentences stored in the document matrix. It's computed as the product of TF and IDF values.

4.6. Model Training:

Training model makes use of machine learning algorithms as selected Logistic Regression, SVM, Decision Tree and Random Forest Classifier used in order to train the model.

4.7. Evaluation and Metrics:

A confusion matrix is a tabular representation used to evaluate the performance of a classification model. It provides specific measurements regarding the accuracy and effectiveness of the model by summarizing the model's predictions against the actual outcomes. The matrix consists of four main components: True Positive (TP), which represents instances correctly predicted as positive; True Negative (TN), which represents instances correctly predicted as negative; False Positive (FP), which represents instances incorrectly predicted as positive; and False Negative (FN), which represents instances incorrectly predicted as negative. These metrics help analysts and data scientists assess the model's ability to classify instances accurately and identify any potential areas for improvement.

- **Accuracy:**

Accuracy is a fundamental evaluation metric that quantifies the overall correctness of a classifier. It measures the proportion of correctly classified instances, including both True Positives and True Negatives, relative to the total number of instances in the dataset. Accuracy is calculated by dividing the number of correctly classified instances by the total number of instances in the dataset.

$$\text{Accuracy} = \frac{|TP|+|TN|}{|TP|+|TN|+|FP|+|FN|}$$

- **Precision:**

Precision is a statistical measure that assesses the accuracy of positive predictions made by a classifier. It indicates the proportion of correctly predicted positive outcomes among all instances classified as positive. Precision is calculated by dividing the number of True Positives by the sum of True Positives and False Positives.

$$\text{Precision} = \frac{|TP|}{|TP|+|FP|}$$

- **Recall:**

Recall, also known as sensitivity, is a metric used to evaluate the classifier's ability to identify all relevant instances in the dataset. It measures the ratio of correctly predicted positive outcomes to all actual positive instances. Recall is calculated as the ratio of True Positives to the sum of True Positives and False Negatives.

$$\text{Recall} = \frac{|TP|}{|TP|+|FN|}$$

- **F1 Score:**

The F1 Score is a composite metric that combines Precision and Recall into a single value, providing a balance between the two measures. It represents the harmonic mean of Precision and Recall and is computed as 2 times the product of Precision and Recall divided by the sum of Precision and Recall.

$$\text{F1 Score} = 2 * \frac{\text{Precision} * \text{Recall}}{\text{Precision} + \text{Recall}}$$

4.8. Tools and Technologies Used:

IDE: Jupyter Notebook

Programming Language: Python

Libraries:

- **Scikit-learn:** Used for machine learning algorithms.
- **NLTK (Natural Language Toolkit):** Employed for text processing and NLP tasks.
- **Pandas:** Utilized for data manipulation and analysis.
- **Matplotlib and Seaborn:** Used for data visualization.

5. PLANE OF RESEARCH:

- Literature survey.
- Study of related work on fake news detection using machine learning algorithms.
- Study of methodology to solve the problem of fake news detection.
- Analyze the challenges of fake news detection and design the workflow of the system.
- Conclude the result of machine learning algorithms for fake news detection.

6. RESULT AND PERFORMANCE:

In our Fake News Detection System project, we're using different ways to measure how well it works. We're looking at things like precision, recall, F1 score, and accuracy. These measures help us see if our system can tell the difference between real news and fake news accurately. Precision tells us how often our system is right when it says something is fake. Recall shows us how much of the fake news our system can catch. The F1 score is like a balance between precision and recall, giving us an overall idea of how good our system is. And accuracy simply tells us how often our system is correct overall. By using all of these measures together, we can really understand if our Fake News Detection System is doing a good job at spotting fake news and stopping misinformation.

Graph 1: Confusion Matrix of Fake News and IFND for Logistic Regression:

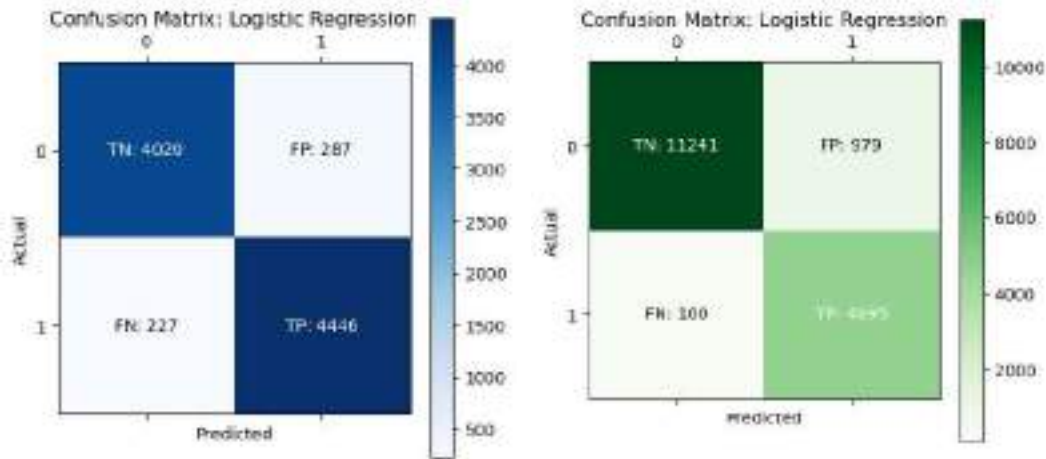

(a) Fake News Dataset

(b) IFND Dataset

The above confusion matrix describes the performance of Logistic Regression algorithm displaying the true positives, true negatives, false positives, and false negatives.

Table 1: Comparison of Fake News and IFND Dataset using Logistic Regression for Fake news:

Dataset	Precision	Recall	F1-Score
Fake News	0.94	0.95	0.95
IFND	0.83	0.98	0.90

Table 1 shows the performance metrics, including precision, recall, and F1-score, for classifying the "Fake" instances in two datasets: "Fake News" and "IFND" using the Logistic Regression Algorithm.

Precision: Precision value for the Fake News dataset is 94% instances identified by the Logistic Regression model were indeed fake and value for the IFND dataset is 83.0% instances identified by the Logistic Regression model were indeed fake.

Recall: Recall value for the Fake News dataset is 95.0% instances identified by the Logistic Regression model were indeed fake and value for the IFND dataset is 98.0% instances identified by the Logistic Regression model were indeed fake.

F1-Score: F1-Score value for the Fake News dataset is 95.0% instances identified by the Logistic Regression model were indeed fake and value for the IFND dataset is 90.0% instances identified by the Logistic Regression model were indeed fake.

Graph 2: Comparison of Logistic Regression Metrics between Fake News and IFND datasets for fake class.

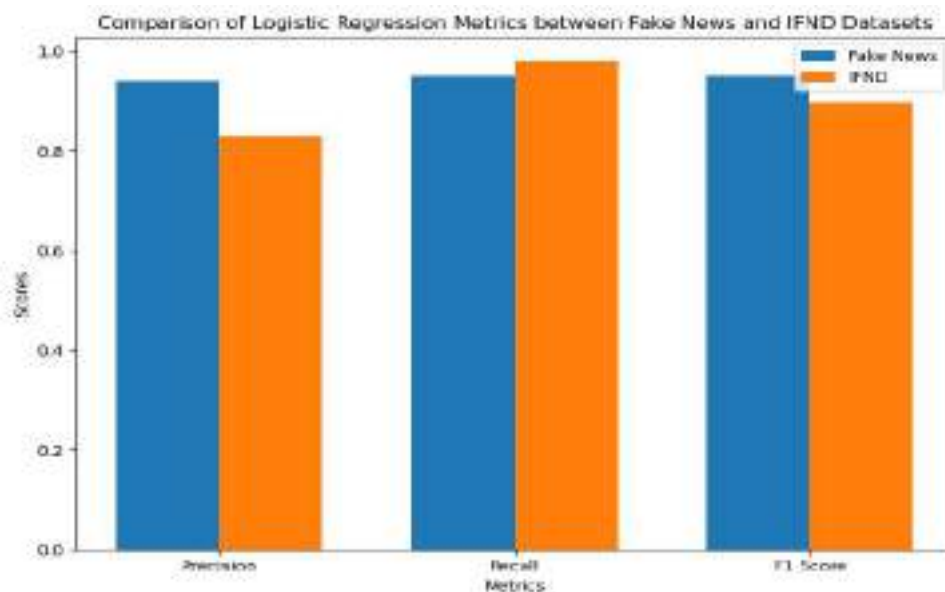

Graph 2 shows a comparative analysis of precision, recall, and F1-score across Fake News and IFND datasets utilizing Logistic Regression classifying fake label.

Table 2: Comparison of Fake News and IFND Dataset using Logistic Regression for True news:

Dataset	Precision	Recall	F1-Score
Fake News	0.95	0.93	0.94
IFND	0.99	0.92	0.95

Table 2 shows the performance metrics, including precision, recall, and F1-score, for classifying the "True" instances in two datasets: "Fake News" and "IFND" using the Logistic Regression Algorithm.

Precision: Precision value for the Fake News dataset is 95.0% instances identified by the model were indeed true and value for the IFND dataset is 99.0% instances identified by the model were indeed true.

Recall: Recall value for the Fake News dataset is 93.0% instances identified by the model were indeed true and value for the IFND dataset is 92.0% instances identified by the model were indeed true.

F1-Score: F1-Score value for the Fake News dataset is 94.0% instances identified by the model were indeed true and value for the IFND dataset is 95.0% instances identified by the model were indeed true.

Graph 3: Comparison of Logistic Regression Metrics between Fake News and IFND datasets for true class.



Graph 3 shows a comparative analysis of precision, recall, and F1-score across Fake News and IFND datasets utilizing Logistic Regression classifying true label.

Graph 4: Confusion Matrix of Fake News and IFND for Support Vector Machine:

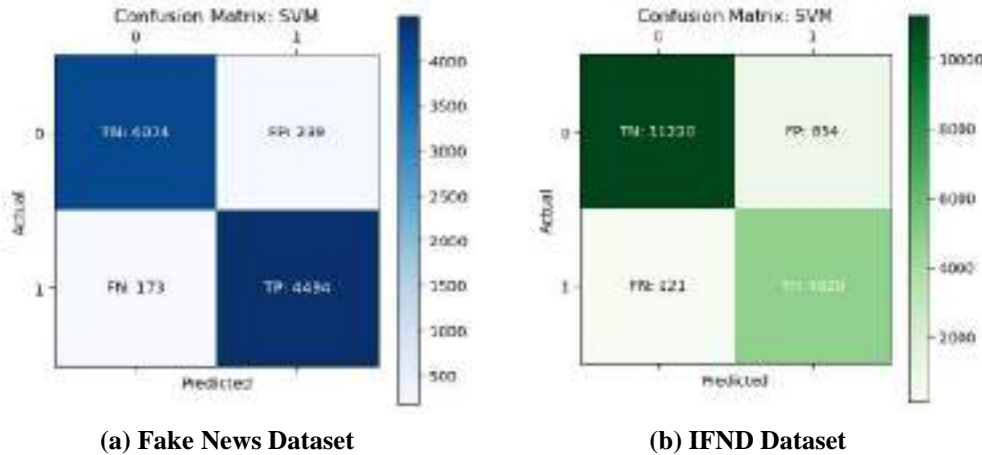

The above confusion matrix describes the performance of Support Vector Machine algorithm displaying the true positives, true negatives, false positives, and false negatives.

Table 3: Comparison of Fake News and IFND Dataset using Support Vector Machine for Fake news

Dataset	Precision	Recall	F1-Score
Fake News	0.95	0.96	0.96
IFND	0.85	0.98	0.91

Table 3 shows the performance metrics, including precision, recall, and F1-score, for classifying the "Fake" instances in two datasets: "Fake News" and "IFND" using the Support Vector Machine Algorithm.

Precision: Precision value for the Fake News dataset is 95.0% instances identified were indeed fake and value for the IFND dataset is 85.0% instances identified by the model were indeed fake.

Recall: Recall value for the Fake News dataset is 96.0% instances identified by the model were indeed fake and value for the IFND dataset is 9.0% instances identified by the model were indeed fake.

F1-Score: F-Score value for the Fake News dataset is 96.0% instances identified by the model were indeed fake and value for the IFND dataset is 91.0% instances identified by the model were indeed fake.

Graph 5: Comparison of Support Vector Machine Metrics between Fake News and IFND datasets for fake class.

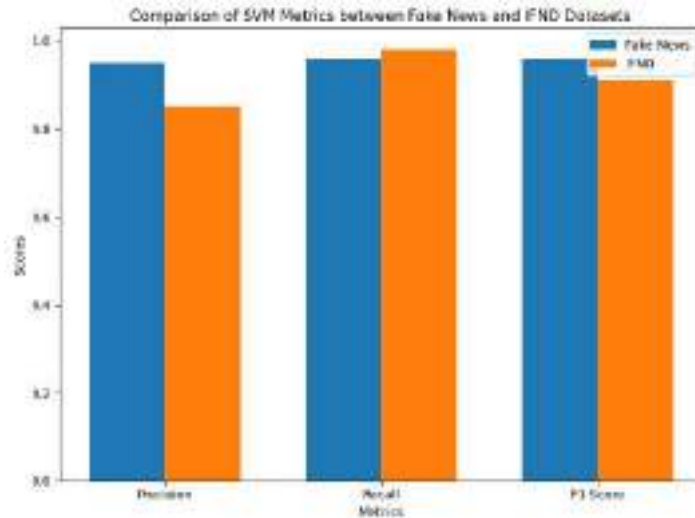

Graph 5 shows a comparative analysis of precision, recall, and F1-score across Fake News and IFND datasets utilizing Support Vector Machine classifying fake label.

Table 4: Comparison of Fake News and IFND Dataset using Support Vector Machine for True news.

Dataset	Precision	Recall	F1-Score
Fake News	0.95	0.96	0.96
IFND	0.99	0.93	0.96

Table 3 shows the performance metrics, including precision, recall, and F1-score, for classifying the "True" instances in two datasets: "Fake News" and "IFND" using the Support Vector Machine Algorithm.

Precision: Precision value for the Fake News dataset is 95.0% instances identified were indeed true and value for the IFND dataset is 99.0% instances identified by the model were indeed true.

Recall: Recall value for the Fake News dataset is 96.0% instances identified by the model were indeed true and value for the IFND dataset is 93.0% instances identified by the model were indeed true.

F1-Score: F-Score value for the Fake News dataset is 96.0% instances identified by the model were indeed true and value for the IFND dataset is 96.0% instances identified by the model were indeed true.

Graph 6: Comparison of Support Vector Machine Metrics between Fake News and IFND datasets for true class.

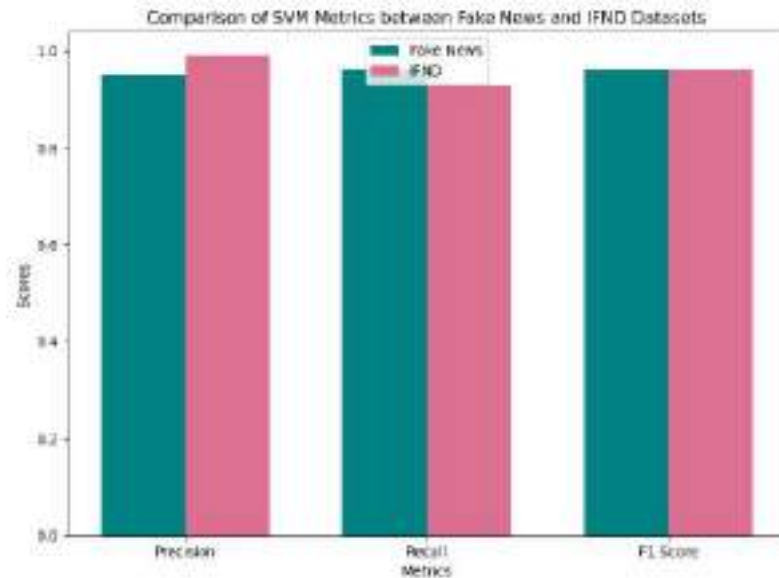

Graph 6 shows a comparative analysis of precision, recall, and F1-score across Fake News and IFND datasets utilizing Support Vector Machine classifying true label.

Graph 7: Confusion Matrix of Fake News and IFND for Decision Tree Classifier:

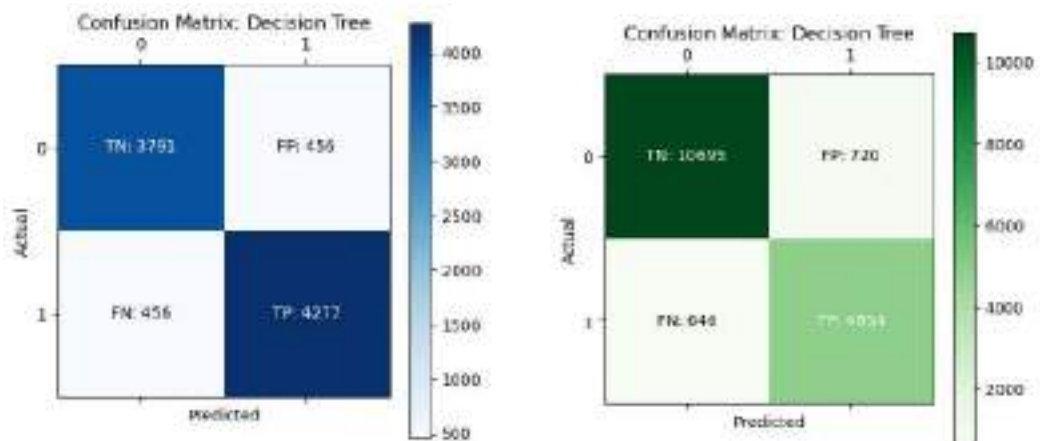

(a) Fake News Dataset

(b) IFND Dataset

The above confusion matrix describes the performance of Decision Tree algorithm displaying the true positives, true negatives, false positives, and false negatives.

Table 5: Comparison of Fake News and IFND Dataset using Decision Tree Classifier for Fake news.

Dataset	Precision	Recall	F1-Score
Fake News	0.90	0.90	0.90
IFND	0.87	0.88	0.88

Table 5 shows the performance metrics, including precision, recall, and F1-score, for classifying the "Fake" instances in two datasets: "Fake News" and "IFND" using the Decision Tree Algorithm.

Precision: Precision value for the Fake News dataset is 90.0% instances identified were indeed fake and value for the IFND dataset is 87.0% instances identified by the model were indeed fake.

Recall: Recall value for the Fake News dataset is 90.0% instances identified by the model were indeed fake and value for the IFND dataset is 88.0% instances identified by the model were indeed fake.

F1-Score: F-Score value for the Fake News dataset is 90.0% instances identified by the model were indeed fake and value for the IFND dataset is 88.0% instances identified by the model were indeed fake.

Graph 8: Comparison of Decision Tree Metrics between Fake News and IFND datasets for fake class.

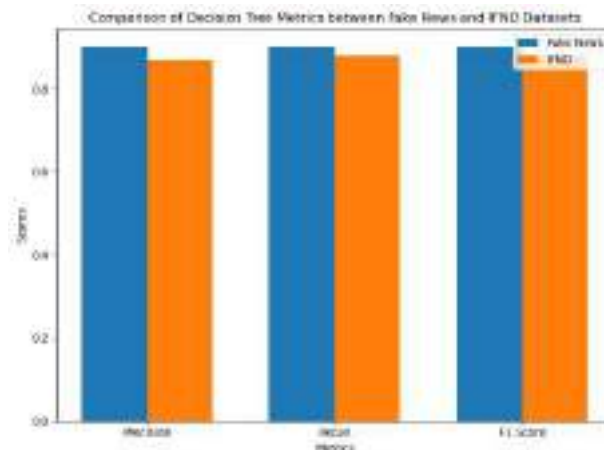

Graph 8 shows a comparative analysis of precision, recall, and F1-score across Fake News and IFND datasets utilizing Decision Tree Classifier classifying fake label.

Table 6: Comparison of Fake News and IFND Dataset using Decision Tree Classifier for True news.

Dataset	Precision	Recall	F1-Score
Fake News	0.89	0.89	0.89
IFND	0.94	0.94	0.94

Table 6 shows the performance metrics, including precision, recall, and F1-score, for classifying the "True" instances in two datasets: "Fake News" and "IFND" using the Decision Tree Algorithm.

Precision: Precision value for the Fake News dataset is 89.0% instances identified were indeed true and value for the IFND dataset is 94.0% instances identified by the model were indeed true.

Recall: Recall value for the Fake News dataset is 89.0% instances identified by the model were indeed true and value for the IFND dataset is 94.0% instances identified by the model were indeed true.

F1-Score: F-Score value for the Fake News dataset is 89.0% instances identified by the model were indeed true and value for the IFND dataset is 94.0% instances identified by the model were indeed true.

Graph 9: Comparison of Decision Tree Metrics between Fake News and IFND datasets for true class.

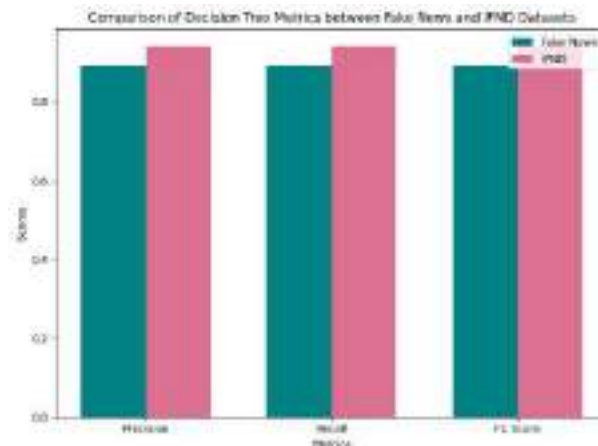

Graph 9 shows a comparative analysis of precision, recall, and F1-score across Fake News and IFND datasets utilizing Decision Tree Classifier classifying true label.

Graph 10: Confusion Matrix of Fake News and IFND for Random Forest Classifier:

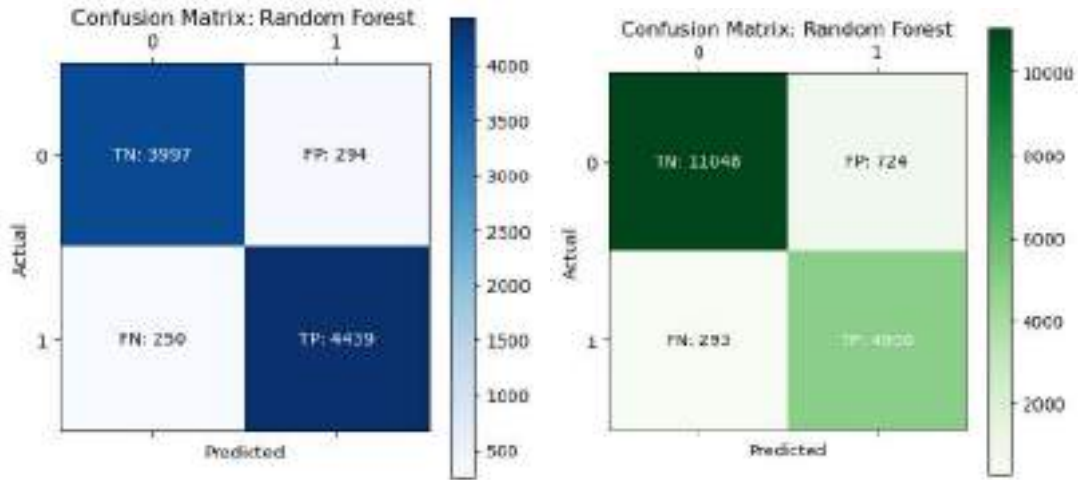

(a) Fake News Dataset

(b) IFND Dataset

The above confusion matrix describes the performance of Random Forest algorithm displaying the true positives, true negatives, false positives, and false negatives.

Table 7: Comparison of Fake News and IFND Dataset using Random Forest Classifier for Fake news.

Dataset	Precision	Recall	F1-Score
Fake News	0.94	0.95	0.94
IFND	0.87	0.94	0.91

Table 7 shows the performance metrics, including precision, recall, and F1-score, for classifying the "Fake" instances in two datasets: "Fake News" and "IFND" using the Random Forest Algorithm.

Precision: Precision value for the Fake News dataset is 94.0% instances identified were indeed fake and value for the IFND dataset is 87.0% instances identified by the model were indeed fake.

Recall: Recall value for the Fake News dataset is 95.0% instances identified by the model were indeed fake and value for the IFND dataset is 94.0% instances identified by the model were indeed fake.

F1-Score: F-Score value for the Fake News dataset is 94.0% instances identified by the model were indeed fake and value for the IFND dataset is 91.0% instances identified by the model were indeed fake.

Graph 11: Comparison of Random Forest Classifier Metrics between Fake News and IFND datasets for fake class.

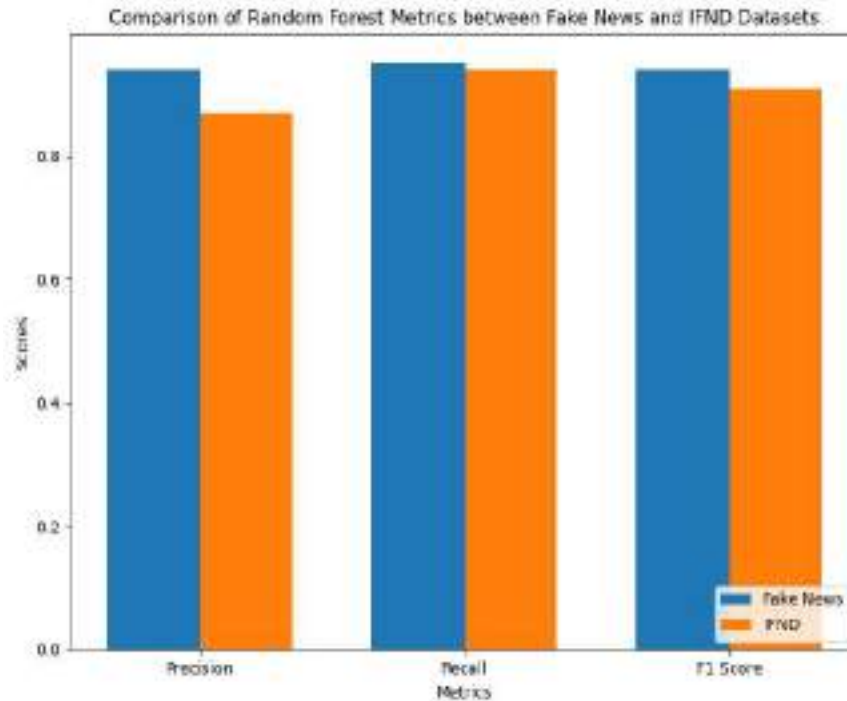

Graph 11 shows a comparative analysis of precision, recall, and F1-score across Fake News and IFND datasets utilizing Random Forest Classifier classifying fake label.

Table 6: Comparison of Fake News and IFND Dataset using Decision Tree Classifier for True news.

Dataset	Precision	Recall	F1-Score
Fake News	0.94	0.93	0.94
IFND	0.97	0.94	0.96

Table 6 shows the performance metrics, including precision, recall, and F1-score, for classifying the "True" instances in two datasets: "Fake News" and "IFND" using the Decision Tree Algorithm.

Precision: Precision value for the Fake News dataset is 94.0% instances identified were indeed true and value for the IFND dataset is 97.0% instances identified by the model were indeed true.

Recall: Recall value for the Fake News dataset is 93.0% instances identified by the model were indeed true and value for the IFND dataset is 94.0% instances identified by the model were indeed true.

F1-Score: F-Score value for the Fake News dataset is 94.0% instances identified by the model were indeed true and value for the IFND dataset is 96.0% instances identified by the model were indeed true.

Graph 12: Comparison of Random Forest Classifier Metrics between Fake News and IFND datasets for true class.

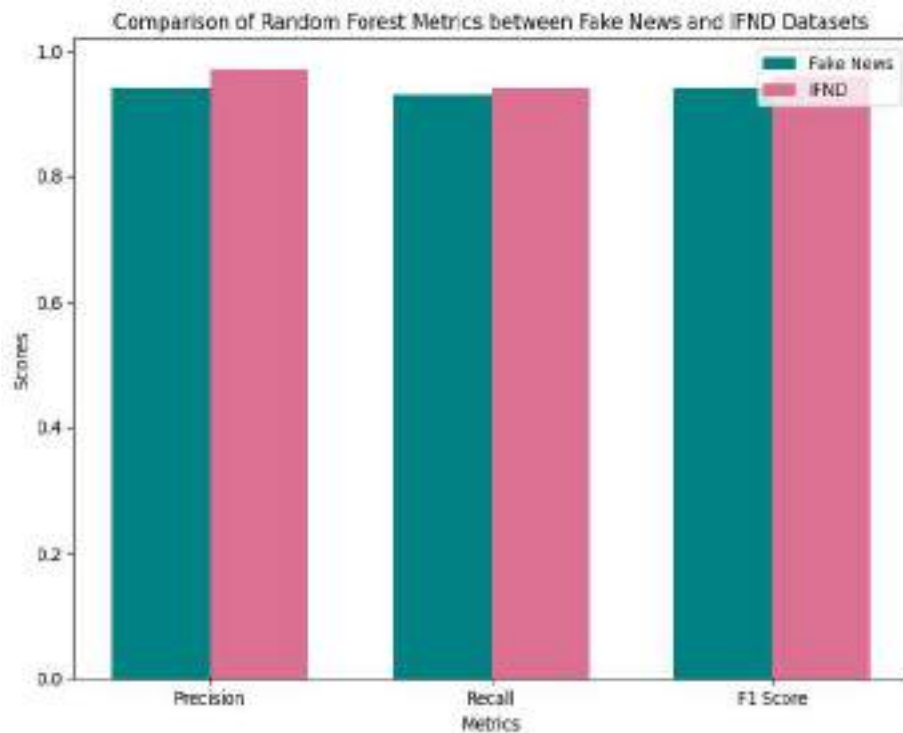

Graph 12 shows a comparative analysis of precision, recall, and F1-score across Fake News and IFND datasets utilizing Random Forest Classifier classifying true label.

Table 7: Comparison of Fake News Detection Algorithms for IFND & Fake News for Class Fake:

Algorithms	Fake News			IFND		
	Precision	Recall	F-Score	Precision	Recall	F-Score
Logistic Regression	0.94	0.95	0.95	0.83	0.98	0.90
SVM	0.95	0.96	0.96	0.85	0.98	0.91
Decision Tree	0.90	0.90	0.90	0.87	0.88	0.88
Random Forest	0.94	0.95	0.94	0.87	0.94	0.91

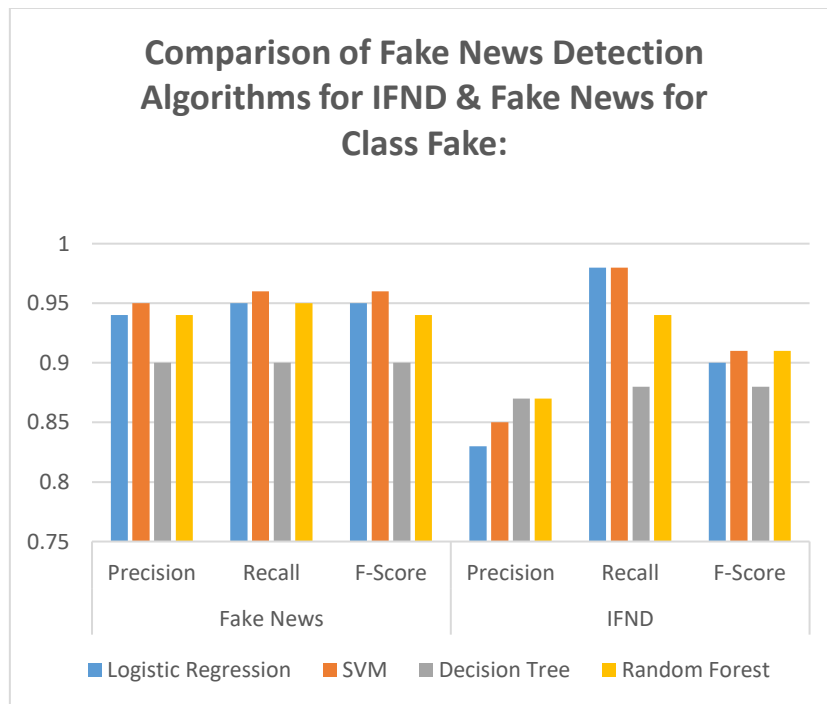
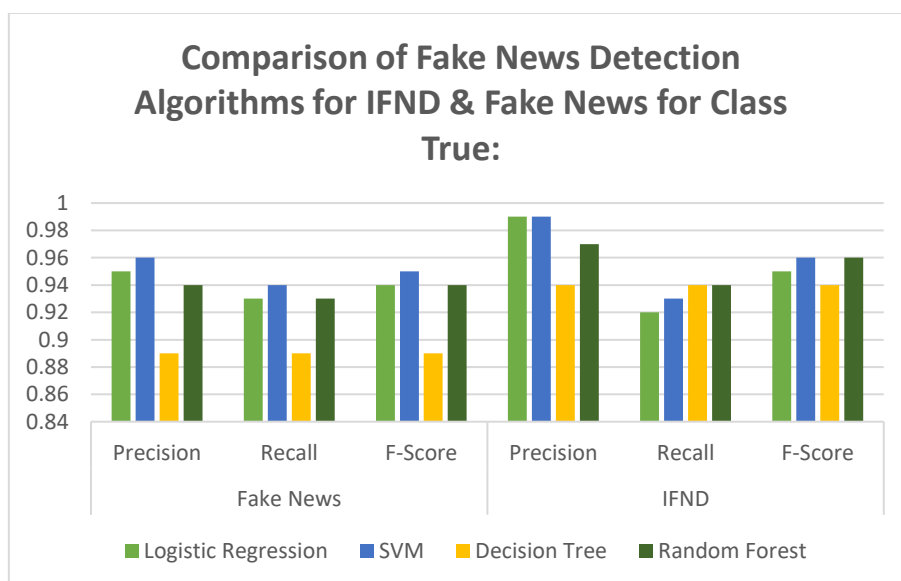

Table 8: Comparison of Fake News Detection Algorithms for IFND & Fake News for Class True:

Algorithms	Fake News			IFND		
	Precision	Recall	F-Score	Precision	Recall	F-Score
Logistic Regression	0.95	0.93	0.94	0.99	0.92	0.95
SVM	0.96	0.94	0.95	0.99	0.93	0.96
Decision Tree	0.89	0.89	0.89	0.94	0.94	0.94
Random Forest	0.94	0.93	0.94	0.97	0.94	0.96



Comparison of Accuracy:

Algorithms	Fake News	IFND
Logistic Regression	94.27 %	93.65 %
SVM	95.41 %	94.26 %
Decision Tree	89.84 %	91.97 %
Random Forest	93.39 %	94.02 %

Above table shows the accuracy of different algorithms for classifying news across two datasets, namely Fake News and IFND, it is observed that the SVM algorithm achieves the highest accuracy for both datasets used with 95.41% accuracy for the Fake News dataset and 94.26% accuracy for the IFND dataset.

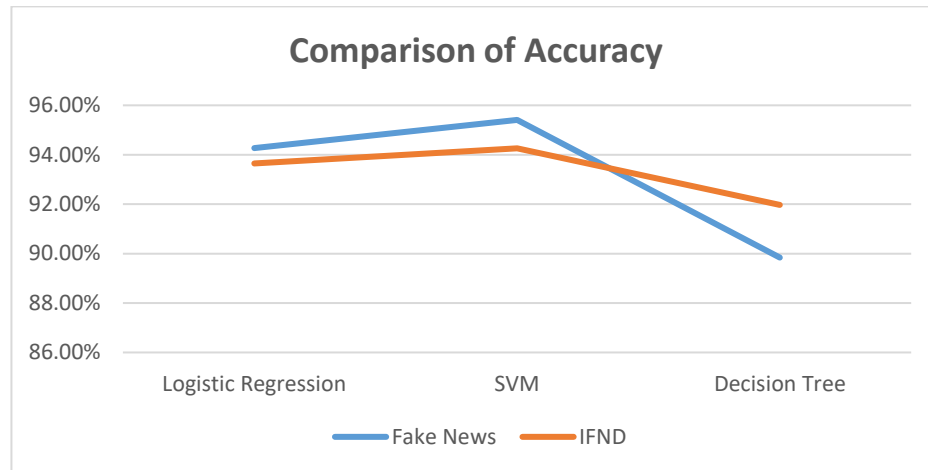

Therefore, if we consider accuracy as the sole criterion for determining the best algorithm for each dataset, the Support Vector Machine algorithm performs best for both the datasets employed for fake news detection.

7. CONCLUSION AND FUTURE SCOPE:

7.1. Conclusion

In conclusion, our study emphasizes the crucial role of machine learning algorithms in tackling the spread of misinformation, commonly known as fake news, in today's digital world. Fake news, which refers to intentionally false information, presents significant challenges to public discourse and societal welfare. By employing advanced techniques like logistic regression, support vector machines, decision trees, and random forest classifiers, we aimed to differentiate between genuine and fabricated news articles using various datasets.

Our results demonstrate promising performance across several key metrics. Specifically, our models achieved high precision, recall, F1-score, and accuracy when tested on the Fake News dataset, indicating strong capabilities in identifying fake news articles. Similarly, our analysis of the IFND dataset showed notable accuracy and effectiveness in categorizing news articles. Through meticulous data gathering, preprocessing, and feature extraction, we enhanced our models to detect patterns characteristic of fake news reliably. The incorporation of state-of-the-art methodologies, such as TF-IDF vectorization and train-test splitting, further strengthened the dependability and efficiency of our detection systems.

7.2. Future Scope:

In the future, the projects plan to improve by analyzing sentiments and emotions in news articles. They will test the model on new datasets to make it more accurate. Additionally, they aim to make the model more user-friendly and boost its accuracy by using specific datasets. The plan is to include more features for better classification and explore the impact of certain networks. A dynamic model will be developed as a downloadable app for users to detect fake news and URLs, extending its capability to identify fake profiles on social media. Furthermore, there is a focus on educating users to research and think critically about news. Lastly, the projects aim to extend their models to various platforms and stay proactive in addressing emerging issues.

8. PUBLICATIONS:

8.1. Presented a paper at Wainganga College of Engineering and Management Nagpur on the topic “Fake News Detection using Machine Learning” by Ms. Achal Kale, Mr. Sparsh Gajbhiye & Dr. Manish T. Wanjari in International Conference on "Innovations in Engineering, Science and Management (ICIESM-2K24)", ISBN: 978-93-5457-951-6.

8.2. Published a paper at SSESAs, Science College, Congress Nagar, Nagpur on the topic “Identifying Fake News using Machine and Deep Learning” by Ms. Achal Kale, Mr. Sparsh Gajbhiye & Dr. Manish T. Wanjari in National Conference on "Research Innovations in ICT and Computing Technologies" (NCRIICT-2023) Special Issue of Journal of Innovation in Sciences (Online), ISSN: 2394-8051, pp 682-685.

References:

- [1]. Pshko Rasul Mohammed Amin, “Fake News Detection Using Machine Learning”, Indonesian Journal of Computer Science, Vol. 12, No. 4, 17 Ags 2023, ISSN 2549-7286.
- [2]. Uma Sharma, Sidarth Saran and Shankar M. Patil, “Fake News Detection Using Machine Learning Algorithms”, International Journal of Creative Research Thoughts (IJCRT), Volume 8, Issue 6 June 2020, ISSN: 2320-2882.
- [3]. M. F. Mridha, Ashfia Jannat Keya, MD. Abdul Hamid, Muhammad Mostafa Monowar, and MD. Saifur Rahman, “A Comprehensive Review on Fake News Detection with Deep Learning”, IEEE Access, VOLUME 9, 18, 2021.
- [4]. Johnson Adeleke Adeyiga, Philip Gbounmi Toriola, Temitope Elizabeth Abioye, Adebisi Esther Oluwatosin, Oluwasefunmi 'Tale Arogundade, “Fake News Detection Using a Logistic Regression Model and Natural Language Processing Techniques”, Research Square, 14 Jul, 2023, DOI: doi.org/10.21203/rs.3.rs-3156168/v1.
- [5]. Fopa Yuffon Amadou Olabi, Mohamadou Moctar, Mikayilou Namba, “Fake News Detection: A Machine Learning Approach using Automated-Text Analysis Technique” ResearchGate, 13 October 2021.
- [6]. Pawar A B, Jawale M A, Kyatanavar D N, “Analyzing Fake News Based on Machine Learning Algorithms”, 2020, doi:10.3233/APC200146.
- [7]. Ajit Patil, “Fake News Detection Using Machine Learning Algorithms”, Researchgate, VOLUME 8, ISSUE 12, 2021, August 2022, ISSN NO: 1869-9391.
- [8]. Anjali Jain, Harsh Khatter, Amit Kumar Gupta, “A smart system for fake news detection using machine learning”, Sep 2019, DOI:10.1109/ICICT46931.2019.8977659.
- [9]. Vasu Agarwal, Parveen Sultana, Srijan malhotra, Amitrajit Sarkar, “Analysis of Classifiers for Fake News Detection”, INTERNATIONAL CONFERENCE ON RECENT TRENDS IN ADVANCE COMPUTING 2019, ICRTAC 2019, 2019.

- [10]. Z Khanam, B N Alwasel, H Sirafi, M Rashid, " Fake News Detection Using Machine Learning Approaches", ResearchGate, 2021, doi:10.1088/1757-899X/1099/1/012040.
- [11]. Abdulaziz Albahr, Marwan Albahar, "An Empirical Comparison of Fake News Detection using different Machine Learning Algorithms", ResearchGate, Vol. 11, No. 9, 2020, 03 February 2022, DOI: 10.14569/IJACSA.2020.0110917.
- [12]. Dr Daaa Salama, Yomna Mahmoud Ibrahim Hassan, Mariam Khaled, "Fake News Detector Using Machine Learning Algorithms", ResearchGate, ISBN: 978-0-9998551-5-7, November 2020.
- [13]. Jagrati Sahu, "Fake News Detection Using Machine Learning Algorithms", International Journal of Science and Research (IJSR), Volume 9 Issue 8, August 2020, ISSN: 2319-7064, DOI: 10.21275/SR20720134651.
- [14]. Muneer V. K, Dr MOHAMED BASHEER K P, Rizwana Kallooravi Thandil, "Fake News Detection and Prediction Using Machine Learning Algorithms", international Journal of Computer Science and Information Technology, Vol. 12 (3), 11 August 2021, ISSN:0975-9646.
- [15]. Vanya Tiwari, Ruth G. Lennon, Thomas Dowling, "Not Everything You Read Is True! Fake News Detection using Machine learning Algorithms", ResearchGate, June 2020, DOI: 10.1109/ISSC49989.2020.9180206.
- [16]. Dr Dammavalam Srinivasa Rao, "Fake News Detection Using Machine Learning Technique", ResearchGate, 21-09-2021, ISBN: 978-93-91842-08-6, DOI: doi.org/10.52458/978-93-91842-08-6-5.
- [17]. Nihel Fatima Baarir, Abdelhamid Djeflal, "Fake News detection Using Machine Learning", 2020 2nd International Workshop on Human-Centric Smart Environments for Health and Well-being (IHSH), May 24,2021, DOI:10.1109/IHSH51661.2021.9378748.
- [18]. Akshay Jain, Amey Kasbe, "Fake News Detection", 2018 IEEE International Students' Conference on Electrical, Electronics and Computer Sciences, September 01,2020.

- [19]. Syed Ishfaq Manzoor, Dr Jimmy Singla, Nikita, "Fake News Detection Using Machine Learning approaches: A systematic Review ", Proceedings of the Third International Conference on Trends in Electronics and Informatics (ICOEI 2019) IEEE Xplore Part Number: CFP19J32-ART, 2019, ISBN: 978-1-5386-9439-8.
- [20]. Jasmine Shaikh, Rupali Patil, "Fake News Detection using Machine Learning", 2020 IEEE International Symposium on Sustainable Energy, Signal Processing and Cyber Security (ISSSC) |978-1-7281-8880-5/20/\$31.00 ©2020 IEEE, 2020, DOI: 10.1109/iSSSC50941.2020.9358890.
- [21]. Anjali Jain, Harsh Khatter, Amit Kumar Gupta, "A smart System for Fake News Detection Using Machine Learning", ResearchGate, September 2019, DOI: 10.1109/ICICT46931.2019.8977659.
- [22]. Z Khanam, B N Alwasel, H Sirafi, M Rashid, "Fake News Detection Using Machine Learning Approaches ", IOP Conf. Series: Materials Science and Engineering, 2021, DOI:10.1088/1757-899X/1099/1/012040.
- [23]. Gerardo Ernesto Rolong Agudelo, Octavio Jose Salcedo Parra, Julio Baron Velandia, "Raising a Model for Fake News Detection Using Machine Learning in Python", IFIP International Federation for Information Processing 2018 Published by Springer Nature Switzerland AG 2018, 2018, doi.org/10.1007/978-3-030-02131-3_52.
- [24]. Mayank Kumar Jain, Dinesh Gopalani, Yogesh Kumar Meena, Rajesh Kumar, "Machine Learning based Fake News Detection using linguistic features and word vector features", 2020 IEEE 7th Uttar Pradesh Section International Conference on Electrical, Electronics and Computer Engineering (UPCON), 2020, DOI: 10.1109/UPCON50219.2020.9376576.

SSESA's, Science College, Congress Nagar, Nagpur
Department of Computer Science
Project List
M.Sc. Semester-IV (2023-24)

Sr. No.	Name of Students	Name of Topics	Co-Guide	Guide
1.	Achal Ashok Kale Sparsh Vijay Gajbiye	Fake News Detection using Python	----	Dr. M. T. Wanjari
2.	Anjali Pradeep Fender Divyani Sureshrao Chandore	Study of deep learning algorithms in facial emotion detection and recognition	Mrs. S. S. Khandalkar	Dr. S. R. Gedam
3.	Ashish Sudhir Waikar Simran Ravindra Kadbe	Lane Detection using deep Learning	----	Dr. M. T. Wanjari
4.	Hemlata Sahebrao Sawankar Kanchan Wasudeo Gondhale	Smart Farming using IOT technologies	----	Mr. A. A. Bodkhe
5.	Leena Siddharth Dupare Payal Yashwant Sharnagat	Gender & Age Detection using Deep Learning	----	Dr. M. T. Wanjari
6.	Manisha Mahadeorao Ingole Sakshi Prakash Manapure	Detection of Credit Card Fraud System	Ms. S. S. Saygaonkar	Dr. A. A. Halder
7.	Nikhil Manoj Gharat Nikhil Sjanlal Gupta	Face Mask Detection System	----	Dr. J. K. Keche
8.	Payal Ganesh Shahu Swati Dilpi Isad	Human Expression Recognition	Mrs. S. S. Khandalkar	Dr. J. K. Keche
9.	Prachi Rameshrao Wasake Saumya Prbhakar Dakhole	Family Photo Detection System	----	Dr. J. K. Keche
10.	Pratik Vijay Pahade Sarang Ishwar Dhanorkar	Traffic Sign Classification	Mrs. A. A. Chandekar	Dr. S. R. Gedam
11.	Pranali Raju Watane Shweta Suresh Vaidya	Automated Attendance System	----	Mr. A. A. Bodkhe
12.	Precti Ajay Rai Riya Ajay Rai	Text Detection and extraction from text images	Ms. S. S. Saygaonkar	Dr. S. R. Gedam
13.	Rashmi Chandrashekhar Ashtankar Samrudhhi Sanjay Telang	Face Detection and Recognition using OpenCV	----	Mr. A. A. Bodkhe
14.	Rasika Ganesh Taralekar Sejal Ranjendra Raut	License Plate Recognition using Matlab	----	Dr. M. T. Wanjari
15.	Tanu Subhash Sangole	Generative Adversarial Nets	Mrs. A. A. Chandekar	Dr. A. A. Halder
16.	Mrunali Prakash Vaidya	Number of People Counter	----	Ms. A. M. Sheikh
17.	Ashwini Arun Naranje	To study of data mining techniques for intrusion detection	---	Ms. A. M. Sheikh



Head

Department of Computer Science

Professor & Head

Department of Computer Science

S S E S Am's Science College



SSES'A Science College Congress Nagar, Nagpur
Department of Computer Science

Project
MCA Semester-II

Session:-2023-24

SR NO.	NAME OF THE STUDENT	NAME OF THE PROJECT TITLE	GUIDE NAME	CO-GUIDE NAME
1	Mayuri Madhusudan Bisen	ATM Simulator System	Dr.M.T.Wanjari	---
2	Dhanashree Vinayak Kulkarni			
3	Jatin Pandurang Tekam	Online Food Delivery App	Dr.M.T.Wanjari	---
4	Bhushan Arun Bagde			
5	Divya Gouriganesh Mendhe	Tourist Guide	Ms.P.M.Dadhe	---
6	Shweta Rewalal Yele			
7	Prabhjot Vikramjeet Arora	Food Receipt Application	Ms.P.M.Dadhe	---
8	Harshal Vijay Masram			
9	Humera Salim Ahmad Khan	Grocery Store App	Dr.J.K.Keche	---
10	Lina Sunil Datir			
11	Aarchal Ashwani Yadav	Assist Bot	Dr.J.K.Keche	---
12	Bhavika Anil Raut			
13	Sana Fridous Shahid Ahmad	Weather Forecasting	Dr.A.A.Halder	Ms.A.S.Chaudhari
14	AnkitaDinesh Zalke			
15	Sakshi Babanraoji Pawar	Virtual Private Network	Dr.S.R.Gedam	---
16	Janvi Daulatrao Deshmukh			
17	Srushti Anil Zade	Online Education Web Application	Dr.V.C.Pande	---
18	Khushi Vinod Sanodiya			
19	Sumit Anil Rodge	Splitwise	Dr.V.C.Pande	---
20	Sejal Nitin Waghe	Online Voting System	Dr.A.A.Halder	Ms.A.S.Chaudhari
21	Devyani Wasnik	QR Code based I'D card Invoice card generator and Email Automation	MS.Asfiya Sheikh	---
22	Bhagyashree Rane			
23	Devesh Thawli	Water Billing Application	Mr.Amol Bodkhe	---
24	Piyush Agre			
25	Vidhi Sunil Sharma	Email System	MS.Asfiya Sheikh	---
26	Vaishnavi Arun Bhusari			
27	Deepti Prakash Kharatkar			
28	Sejal Sudhir Hadke	Vehicle Breakdown	Dr.S.R.Gedam	---
29	Shrish Kalambe	Health and Fitness Application	Mr.Amol Bodkhe	---
30	Praful Borkute			



Professor & Head
 Department of Computer Science
 S S E S Am's Science College
 Congress Nagar, Nagpur

PROJECT REPORT
ON
ATM SIMULATOR SYSTEM

Submitted to
Rashtrasant Tukadoji Maharaj Nagpur University
NAGPUR

In partial fulfillment of
MASTER IN COMPUTER APPLICATIONS
(PART-I SEMESTER-II) Examination

Submitted by
Dhanashree Kulkarni
Mayuri Bisen

Under the guidance of
Dr. M. T. Wanjari
Assistant Professor
Department of Computer Science



DEPARTMENT OF COMPUTER SCIENCE
Shri Shivaji Education Society Amravati's,
SCIENCE COLLEGE
CONGRESS NAGAR-NAGPUR-12

2023-2024

Department of Computer Science,
Shri Shivaji Education Society
Amravati's,
Science College, NAGPUR-440012.

CERTIFICATE

This is to certify that **Dhanashree Kulkarni and Mayuri Bisen** has successfully completed the project work entitled **ATM Simulator System** under my guidance towards the fulfillment of the degree of **MASTER IN COMPUTER APPLICATIONS (PART-I SEMESTER-II)** submitted to Rashtrasant Tukadoji Maharaj Nagpur University, Nagpur during academic year 2023-2024.

To the best of my knowledge the matter presented here in this project has not been presented earlier for similar degree.

Place: Nagpur
Date:

19/06/24
Project Guide
Dr. M. T. Wanjari
Assistant Professor
(Department of Computer Science)
Assistant Professor
Department of Computer Science
S.S.E.S. Amravati Science College,
Congress Nagar, Nagpur

EXTERNAL EXAMINER

INTERNAL EXAMINER

DECLARATION

To,

The Principal
Shri Shivaji Education Society Amravati's,
Science College, Congress Nagar,
Nagpur -440012.

Respected Sir,

We the undersigned, hereby declare that the project work entitled **ATM Simulator System** submitted to Rashtrasant Tukadoji Maharaj Nagpur University, Nagpur. This is our own independent work. This is our original work and has not been submitted anywhere for any degree. The system presented here in has not been duplicated from any other source.

Understand that any such copying is liable to be punished in any way the university authority may deems fit.

Thanking you,

Place: Nagpur
Date:

Yours Sincerely

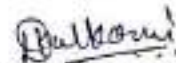

Dhanashree Kulkarni

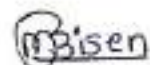

Mayuri Bisen

ACKNOWLEDGEMENT

We wish to express my sincere thanks to many persons who helped me to develop the project. We extend our thanks to respected Principal, **Prof. M. P. Dhore**, Science College, Nagpur for providing the infrastructure and facilities without which it would have been impossible to complete this hard task.

Our foremost thanks are to **Prof. S. R. Pande**, Head of Department of Computer Science who has guided me in completing this project report. I take the opportunity to express my deep sense of gratitude and whole hearted thanks for his inspiration and guidance throughout the course of this project.

We are thankful to our Guide **Dr. M. T. Wanjari** for their constant inspiration and guidance throughout the course of this project work.

We express our gratitude to all members of teaching and non-teaching staff of the Department of Computer Science for their co-operation during the verification of the project.

Place: Nagpur

Date:

Dhanashree Kulkarni &
Mayuri Bisen
M.C.A Part I (Semester-II)

INDEX

Sr. No.	Name of Topic	Page No.
1.	INTRODUCTION Project Description Objectives Features	1
2.	SURVEY OF TECHNOLOGY	6
3.	REQUIREMENTS AND ANALYSIS Software and Hardware Requirements Feasibility Study Economic Technical Operational	10
4.	SYSTEM DESIGN Program Flowchart ER Diagram	
5.	IMPLEMENTATION AND TESTING Coding Details (Only for I and II Year Students) Testing Approach Unit Testing Integrated Testing System Testing Implementation and Maintenance	12
6.	CONCLUSIONS Limitations of the System Conclusion Future Scope of the Project	39
7.	BIBLIOGRAPHY	44

Chapter-1
INTRODUCTION

The ATM Simulator System provides an interactive platform for users to simulate their banking transactions in a controlled environment. Leveraging Java and the Swing GUI library, this system demonstrates the flow of a real ATM application, allowing users to create accounts, manage and more.

Automated Teller Machine enables the clients of a bank to have access to their account without going to the bank. This is achieved only by development the application using online concepts. The ATM system is the project which is used to access their bank accounts in order to make cash withdrawals. Whenever the user need to make the cash withdraws, they can enter their PIN Number (Personal Identification Number) and it will display the amount to be withdrawn in the form of 50,100 and 500. Once their withdrawn was successful, the amount will be debited in their account.

The ATM system is developed in java and back-end database as MySQL. Java is a widely used object-oriented programming language and software platform that runs on billions of devices. One major advantage of developing software with Java is its portability. Once we wrote code for a Java program on a notebook computer, it can be easily moved to a mobile device. The ATM will communicate each transaction to the database and obtain verification that it was allowed by the database. In the case of a cash withdrawal, a second message will be sent after the transaction has been physically completed (cash dispensed or envelope accepted). If the database determines that the customer's PIN is invalid, the customer will be required to re-enter the PIN before a transaction can proceed.

The ATM Simulator System is a Java-based project designed to emulate the functionality of an Automated Teller Machine (ATM). This system aims to provide users with a virtual platform to perform basic banking operations conveniently and securely.

When the product is implemented, the user who uses this product will be able to see all the information and services provided by the ATM, when he enters the necessary option and arguments. The product also provides services like request for cheques, deposit cash

and other advanced requirement of the user. The data is stored in the database and is retrieved whenever necessary. The implementation needs ATM machine hardware to operate or similar simulated conditions can also be used to successfully use the developed product.

The application design maintains the information of the accounts of various customers including the information of the ATM cards, their types Credit cards, Debit Cards and the transactions done by the customers through the ATM machine centers with co-relation of the Banking Services.

The stored details also include the information of the various centers in and around the ATM services, which help in the relational maintenance of every transaction in the ATM Machine by the customers with their concerned branch operations.

The major functions of the overall ATM system are to keep the following component intact.

- Consistency of the ATM System
- Integrity of the ATM System
- Data Security for all customers
- Data Reliability, Unique and Accuracy
- User Friendly web pages at admin side and User side
- To check that the banking ATM system overcome the hurdles of the version specific standards

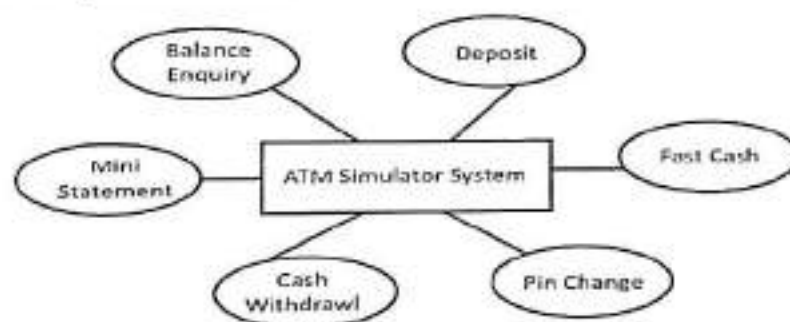

Fig. 1: Architecture of ATM Simulator System

To develop this ATM system the entire operation has been divided into the following step:

1. Verification process
2. Language, service and account selection

3. Bank services
4. Transactions
5. Special services

The program is designed in such way that the user has card number and pin number. Once verified, he is provided a menu and he/she had to enter the option provided in the menu.

For example, when the user wants to view the list of payment history than he/she had to enter the option for payment history provided in the main menu. When the option is entered along with the respective argument, then the payment history is displayed on the screen.

The user also must be given option to browse through the pages like previous page , next page, etc. The user may experience a delay in retrieving or viewing the data, when there are many users logged on to the same bank branch system.

Need for the ATM System:

Millions of times per day around the globe people are instantly withdrawing money at automatic teller machines(ATMs).Given the fast-pace of the world today, it is not surprising that the demand for access to quick cash is so immense.

The power of ATMs would not be possible without secure connections.

PROJECT DESCRIPTION

Need for the software:

Now a days every one is very busy in their work. So they feel that the job must be easier so the system is used to reduce their work which is done in the ATM system. Instead of keeping lots of paper into a record or file and it may be missed somewhere so, this system help to keep the record of the customer it also keeps the details of the customer. It is also easy to access.

Problem Description:

The system mainly used by the bank clients. When a client comes to ATM centre to update and delete their account. It reduces time consumption and lot of paperwork. For any single operation it involves numerous references and updating also takes subsequent changes in other places.

OBJECTIVES

Our main objective is to speed up the transaction done by customers. No manual transactions needed generally.

1. To Providing a practical learning experience for students studying Java programming or software engineering by implementing real-world applications.
To Understanding Banking Operations performed at ATMs, such as cash withdrawals, balance inquiries, fund transfers, and account management.
2. Creating a simulated environment that mimics the user interaction and transaction flow of a physical ATM machine, enabling users to practice without accessing real banking systems.
3. To incorporating security features and practices into the system to educate users about the importance of secure authentication, data encryption, and transaction security.

FEATURES

The features of an ATM simulator in Java typically include functionalities that mimic those of a real-world Automated Teller Machine. Here's a list of common features that can be implemented as:

User Authentication:

Log in with a user ID and PIN code.

Implement security measures to prevent unauthorized access.

Account Management:

View account balance.

Display account information such as account number, name, and account type.

Cash Transactions:

Withdraw cash from the account.

Deposit cash into the account.

Check available balance before and after transactions.

Receipt Generation:

Print or display transaction receipts for user records.

Include details such as transaction type, amount, date, and remaining balance.

Chapter-2
SURVEY OF TECHNOLOGY

In this project we are using two technologies and they are:

i. **INTELLIJ IDEA:**

IntelliJ IDEA is a highly popular integrated development environment (IDE) developed by JetBrains. It is designed primarily for Java but also supports a wide range of programming languages including Kotlin, Groovy, Scala, and more. This software development tool is highly beneficial for programmers since with it they can efficiently create, edit, debug, and manage code in various applications. Choosing IntelliJ IDEA as your integrated development environment (IDE) offers numerous compelling reasons that make it a preferred choice for developers across various domains.

Smart Code Assistance: IntelliJ IDEA provides unparalleled code assistance, including intelligent code completion, analysis, and suggestions. It understands your code context and offers context-aware recommendations, helping you write code faster and with fewer errors.

Advanced Refactoring: The IDE offers a wide range of automated refactoring tools that make it easy to improve code quality, readability, and maintainability. You can safely rename variables, extract methods, and more, with confidence.

Code Inspection: With its built-in code analysis, IntelliJ IDEA helps you identify potential issues and bugs in real-time. It provides quick fixes and suggestions to maintain code quality, reducing debugging time.

Version Control Integration: Seamless integration with popular version control systems like Git, SVN, and Mercurial simplifies collaboration and version tracking, making team development smoother.

Built-in Build Tools: The IDE supports various build systems such as Maven and Gradle and is also capable of streamlining project management and dependency resolution. This helps you focus more on coding and less on configuration.

Database Tools: IntelliJ IDEA offers comprehensive database tools, including SQL support, database diagrams, and data source management. You can work with databases directly within the IDE, enhancing your productivity.

Testing and Code Coverage: It includes a robust test runner and code coverage tools that ensure your code is thoroughly tested. This helps in early bug detection and improves overall code quality.

Plugin Ecosystem: The IDE comes with a vast library of plugins developed by the community. This vast plugin helps to extend its functionality to support additional languages, frameworks, and tools.

Cross-platform Development: Whether you're developing web, desktop, mobile, or cloud applications, IntelliJ IDEA provides a unified environment for all your projects, saving you time and effort.

Continuous Updates: JetBrains regularly releases updates, adding new features, enhancing performance, and fixing bugs, ensuring that you have access to the latest tools and technologies.

Kotlin Support: IntelliJ IDEA has native support for Kotlin, JetBrains' modern programming language. This ensures that Kotlin developers have top-notch development experience.

User-Friendly UI: The IDE features a user-friendly interface with customizable themes and keyboard shortcuts, allowing you to tailor it to your preferences.

Community and Ultimate Editions: IntelliJ IDEA comes in two editions, with the Community Edition being free and open-source, making it accessible to developers with various budgets.

ii. MY SQL WORKBENCH

MySQL Workbench is a unified cross-platform, open-source relational database design tool that adds functionality and ease to MySQL and SQL development work. MySQL Workbench provides data modeling, SQL development, and various administration tools for configuration. It also offers a graphical interface to work with the databases in a structured way. You can create a Graphical Model using MySQL Workbench

MySQL Workbench provides reverse engineering for live databases to models

MySQL Workbench offers a forward engineering model to a script/live database

There are various relational database management systems present in the tech world today, such as Microsoft SQL Server, Microsoft Access, Oracle, DB2, etc.

Here are some reasons why people use MySQL over other Database Management Systems.

- Multiple Storage Engines
- High Performance

Chapter-3
REQUIREMENTS
AND ANALYSIS



Fig 1: Login Page Output

Main_Class.java

```

package atm.simulator.system;
import javax.swing.*;
import java.awt.*;
import java.awt.event.ActionEvent;
import java.awt.event.ActionListener;
public class main_Class extends JFrame implements ActionListener {
    JButton b1,b2,b3,b4,b5,b6,b7;
    String pin;
    main_Class(String pin){
        this.pin = pin;
        ImageIcon i1 = new
        ImageIcon(ClassLoader.getResource("icon/atm2.png"));
        Image i2 =
        i1.getImage().getScaledInstance(1550,830,Image.SCALE_DEFAULT);
        ImageIcon i3 = new ImageIcon(i2);
        JLabel l3 = new JLabel(i3);
        l3.setBounds(0,0,1550,830);
    }
}

```

```
add(l3);

JLabel label = new JLabel("Please Select Your Transaction");
label.setBounds(430,180,700,35);
label.setForeground(Color.WHITE);
label.setFont(new Font("System",Font.BOLD,28));
l3.add(label);

b1 = new JButton("DEPOSIT");
b1.setForeground(Color.WHITE);
b1.setBackground(new Color(65,125,128));
b1.setBounds(410,274,150,35);
b1.addActionListener(this);
l3.add(b1);

b2 = new JButton("CASH WITHDRAWAL");
b2.setForeground(Color.WHITE);
b2.setBackground(new Color(65,125,128));
b2.setBounds(700,274,150,35);
b2.addActionListener(this);
l3.add(b2);

b3 = new JButton("FAST CASH");
b3.setForeground(Color.WHITE);
b3.setBackground(new Color(65,125,128));
b3.setBounds(410,318,150,35);
b3.addActionListener(this);
l3.add(b3);

b4 = new JButton("MINI STATEMENT");
b4.setForeground(Color.WHITE);
b4.setBackground(new Color(65,125,128));
b4.setBounds(700,318,150,35);
b4.addActionListener(this);
```



Fig 2: Main Class Output

Deposit.java

```

package atm.simulator.system;
import javax.swing.*;
import java.awt.*;
import java.awt.event.ActionEvent;
import java.awt.event.ActionListener;
import java.util.Date;

public class Deposit extends JFrame implements ActionListener {
    String pin;
    TextField textField;
    JButton b1, b2;
    Deposit(String pin) {
        this.pin = pin;
        ImageIcon i1 = new
        ImageIcon(ClassLoader.getResource("icon/atm2.png"));
        Image i2 =
        i1.getImage().getScaledInstance(1550,830,Image.SCALE_DEFAULT);
        ImageIcon i3 = new ImageIcon(i2);
        JLabel l3 = new JLabel(i3);
        l3.setBounds(0,0,1550,830);
        add(l3);

        JLabel label1 = new JLabel("ENETR AMOUNT YOU WANT TO DEPOSIT");
        label1.setForeground(Color.WHITE);
        label1.setFont(new Font("System", Font.BOLD, 16));
        label1.setBounds(460,180,400,35);
    }
}

```



```

l3.add(label1);

textField = new TextField();
textField.setBackground(new Color(65,125,128));
textField.setForeground(Color.WHITE);
textField.setBounds(460,230,320,25);
textField.setFont(new Font("Raleway", Font.BOLD,22));
l3.add(textField);

b1 = new JButton("DEPOSIT");
b1.setBounds(700,362,150,35);
b1.setBackground(new Color(65,125,128));
b1.setForeground(Color.WHITE);
b1.addActionListener(this);
l3.add(b1);

b2 = new JButton("BACK");
b2.setBounds(700,406,150,35);
b2.setBackground(new Color(65,125,128));
b2.setForeground(Color.WHITE);
b2.addActionListener(this);
l3.add(b2);

setLayout(null);
setSize(1550,1080);
setLocation(0,0);
setVisible(true);
}
@Override
public void actionPerformed(ActionEvent e) {
    try {
        String amount = textField.getText();
        Date date = new Date();
        if (e.getSource()==b1){
            if (textField.getText().equals("")){
                JOptionPane.showMessageDialog(null,"Please enter the Amount you
want to Deposit");
            }else {
                Conn c = new Conn();
                c.statement.executeUpdate("insert into bank values('"+pin+"',
"+date+"','Deposit', '"+amount+"')");
                JOptionPane.showMessageDialog(null,"Rs. "+amount+" Deposited
Successfully");
                setVisible(false);
                new main_Class(pin);
            }
        }else if (e.getSource()==b2){
            setVisible(false);
            new main_Class(pin);
        }
    }
}

```

```

    }catch (Exception E){
        E.printStackTrace();
    }
}
public static void main(String[] args) {
    new Deposit("");
}
}

```



Fig 3: Deposit class output

Withdrawl Class:

```

package atm.simulator.system;
import javax.swing.*;
import java.awt.*;
import java.awt.event.ActionEvent;
import java.awt.event.ActionListener;
import java.sql.ResultSet;
import java.util.Date;

public class Withdrawl extends JFrame implements ActionListener {
    String pin;
    TextField textField;
    JButton b1, b2;
    Withdrawl(String pin){
        this.pin=pin;
        ImageIcon i1 = new
        ImageIcon(ClassLoader.getResource("icon/atm2.png"));
        Image i2 =

```



Chapter-7
Bibliography

1. Complete Reference by HERBERT Schildt (TMH)
2. Programming with Java by C Muthu (McGraw Hill)
3. Black Book on Java
4. <http://examples.javacodegeeks.com/desktop-java/swing/jbutton/set-action-command-forjbutton/>
5. http://www.java2s.com/Questions_And_Answers/Java-File/text-file/password.htm
6. <http://stackoverflow.com/questions/4716503/best-way-to-read-a-text-file>

S.S.E.A'S Science College, Congress Nagar, Nagpur

Environmental Studies Project

List of B.Sc-II (Sem- III & IV) (2023-2024)

Project Guide: Dr. R.P.Sonwalkar & Dr. P.B. Zhamarkar

Sr. No	Name of Students	Project Topic
1	BAGHEL SONAM SANTOSHKUMAR	Pollution, Pollution Control and Prevention
2	BAIG TASMIYA HAMID	Climate Change
3	BAWANKULE LAXMI DEVIDAS	Biodiversity
4	BHASMOTE ARADHANA RAJENDRA	Recycling
5	DESHMUKH JANHAVI VIRENDRA	Sustainability
6	DHOK SOKSHAM NISHANT	Energy Conservation
7	GAJBHIYE SWEJAL PRASHANT	Environmental Economics
8	IRGURALA VIDYA CHANDRAIAH	Wildlife Conservation
9	JIBHEKAR SAMRUDDHI KISHOR	Environmental Ethics
10	KALE AVANI PREMDAS	Renewable Energy
11	KHADSE CHETANA MORESHWAR	Marine Conservation
12	KUBADE TEJASWI MOTIRAM	Water Conservation
13	LOKHANDE KASHISH SUHAS	Solar Panel and Water Turbines
14	LUTE SUHANI RAMESHWAR	Human Impact on Forest
15	MENDWADE AISHWARYA PRAKASH	Water Purification
16	NAMDEO ARYAN UMASHANKAR	Pollution, Pollution Control and Prevention
17	PAIGAMI MANISH RAJENDRA	Climate Change
18	PAL VAISHNAVI VINOD	Biodiversity
19	SAHU APURVA TAPAN	Recycling
20	SAPATE PORNIMA PRABHU	Sustainability
21	THAKARE SUHANI SUKHADEO	Energy Conservation
22	THAKUR KRITI AINKATRAO	Environmental Economics
23	TOMAR TANU LXANDERKUMAR	Wildlife Conservation
24	TONGE SUHANI ANAND	Environmental Ethics
25	VYAS HIMANSHU MUKESH	Renewable Energy
26	WAHANE PREMANSHU ANIL	Marine Conservation
27	WAHANE TEJASVI PRAVIN	Water Conservation
28	WASNIK RUTIKA VINAYAK	Solar Panel and Water Turbines
29	CHANIANA KIRANPREET KAUR SARVJEET SINGH	Human Impact on Forest
30	DUBEY ISHA ROSHAN	Water Purification
31	FULZELE KASHISH GAJENDRA	Pollution, Pollution Control and Prevention

32	GOWARDIPE KAJAL PURUSHOTTAM	Climate Change
33	HEDAOO DHIRAJ RAJENDRA	Biodiversity
34	KAMBLE NAYAN ASHOK	Recycling
35	KANGALE ACHAL RUSHI	Sustainability
36	KHOTELE MAYANK HEMANTKUMAR	Energy Conservation
37	MISHRA SHASHWAT RAMAKANT	Environmental Economics
38	MONDHE VISHAL VISHWANATH	Wildlife Conservation
39	SINGH KASHISH NAGENDRA	Environmental Ethics
40	SINGH SHEETAL AZAD	Renewable Energy
41	SONWANE BHAGYASHREE CHANDRAKUMAR	Marine Conservation
42	YADAV TAMANNA VIJAY	Water Conservation
43	BAWANKULE ANURAG AVIN	Solar Panel and Water Turbines
44	CHANODE SONU SHESHRAO	Human Impact on Forest
45	CHAUDHARI SANIKA RAVINDRA	Water Purification
46	DABHADE SAURABH DADARAO	Pollution, Pollution Control and Prevention
47	DAKHOLE MUGDHA RAJESH	Climate Change
48	DANGORE SOHAM NITIN	Biodiversity
49	DHAWADE SHRAWANI DATTA	Recycling
50	DOLAS SAHARSH SURESH	Sustainability
51	GAIKI VEDANT PRASHANT	Energy Conservation
52	GANVIR SALONI RAJKUMAR	Environmental Economics
53	GIRDE CHETNA PRAKASH	Wildlife Conservation
54	HEDAU SAYLI VIVEK	Environmental Ethics
55	KAMBLE DIVYA DINESH	Renewable Energy
56	KHANDATE NEHA KISAN	Marine Conservation
57	KHARWALE ASHWINI RATIRAM	Water Conservation
58	MAMULKAR RAJVI PRASHANT	Solar Panel and Water Turbines
59	MANKAR SAYALI DEVRAO	Human Impact on Forest
60	MARWADE SANIKA BHASKAR	Water Purification
61	MOURYA HARSHIT PRAMOD	Pollution, Pollution Control and Prevention
62	NASARE NIKHIL NARAYAN	Climate Change
63	NASARE RAHUL RAJENDRA	Biodiversity
64	NIRANJANE VRUDDHI SAWAN	Recycling
65	PARDHI CHETANA MANISH	Sustainability
66	PATIL PRERNA HANAMANT	Energy Conservation
67	RAMTEKE SHASHANK NITIN	Environmental Economics
68	RATTHE ARYA VINOD	Wildlife Conservation
69	SAHU DEVSHRI ASHOK	Environmental Ethics
70	SULAKHE MANDAR CHANDRASHEKHAR	Renewable Energy
71	SURYAWANSHI VAIBHAV DURYODHAN	Marine Conservation
72	TALNIKAR LAVANYA RAMAKANT	Water Conservation

73	THAKARE PRACHI DILIP	Solar Panel and Water Turbines
74	TIWARI PRIYA RAKESHKUMAR	Human Impact on Forest
75	TUBID YASHWARDHAN SIDHESHWAR	Water Purification
76	BANGRE ARPIT MANOJ	Pollution, Pollution Control and Prevention
77	BHAYDE PRATEEKSHA PRAVIN	Climate Change
78	BHENDARKAR KHUSHRANG JAIPRAKASH	Biodiversity
79	BHUJADE RUTUJA RAJENDRA	Recycling
80	BISEN SAGAR ARUN	Sustainability
81	BISWAS APARAJITA APURBAKUMAR	Energy Conservation
82	DUDHANKAR RUPALI RAJESH	Environmental Economics
83	GAWANDE NEHA GAJENDRA	Wildlife Conservation
84	GONDANE ISHA DINESH	Environmental Ethics
85	GUPTA PRINCY ASHOK	Renewable Energy
86	GUPTA VAISHNAVI BHARAT	Marine Conservation
87	INGLE AJINKYA MAHENDRA	Water Conservation
88	KARANDE ASTHA GANGADHAR	Solar Panel and Water Turbines
89	KHODE YASH SANJAY	Human Impact on Forest
90	KUITE ANUSHKA VINOD	Water Purification
91	LICHADE AYUSHI KRISHNA	Pollution, Pollution Control and Prevention
92	LOKHANDE AKANSHA ARVIND	Climate Change
93	MOHADIKAR AKSHITA PUSHPARAJ	Biodiversity
94	NAGRIKAR ANUJA JAYANT	Recycling
95	PANDEY KAMAL BRIJESH	Sustainability
96	PARATE PRANJAL JEEVAN	Energy Conservation
97	SATFALE RAKSHA SANJAY	Environmental Economics
98	SINGALWAR FALGUNI ANIL	Wildlife Conservation
99	TOMAR ATHARVA JITENDRA	Environmental Ethics
100	WAGDE ASHLESHA YUVRAJ	Renewable Energy
101	WAGHE SAKSHI SANDIP	Marine Conservation
102	YADAV SEJAL ASHOK	Water Conservation
103	AKRE KHUSHI KAILASH	Solar Panel and Water Turbines
104	BAGDE SHREYA TARACHAND	Human Impact on Forest
105	BHATTALWAR VARAD ATUL	Water Purification
106	DAWARE SARVESH SUDHIR	Pollution, Pollution Control and Prevention
107	DOBLE VAISHNAVI GAJANAN	Climate Change
108	GHORMARE KRUTIKA ANKUSH	Biodiversity
109	GHUGAL ABHISHAKTI HARIBHAU	Recycling
110	HULKE VINAY MORESHWAR	Sustainability
111	KODANE PUNESHA DILIP	Energy Conservation
112	LENDE SANJANA KISHORJI	Environmental Economics
113	LUTE HIMANSHI RAMESH	Wildlife Conservation

114	MOHATURE TANHVI CHANDRASHEKHAR	Environmental Ethics
115	AYYAGARI RENUKA SUDHAKAR	Renewable Energy
116	BANTE SHRADDHA GUDDU	Marine Conservation
117	BEHAR KHUSHI RAJU	Water Conservation
118	BHAISARE CHETANA DINESH	Solar Panel and Water Turbines
119	BHIMTE SHRIYA SURENDRAKUMAR	Human Impact on Forest
120	CHOUDHARY VAISHNAVI CHANDRAKANT	Water Purification
121	GANVIR ANUSHKA ANIL	Pollution, Pollution Control and Prevention
122	GOSWAMI DIVYA VIKAS	Climate Change
123	GOSWAMI LAXMI KISHOR	Biodiversity
124	GUPTA SHREYA RAVINDRA	Recycling
125	KALE MRUNALI CHANDRAJEET	Sustainability
126	KOLHE HARSHINI ARVIND	Energy Conservation
127	LONDE HARSHADA RAJESH	Environmental Economics
128	MOHOD SAMRUDDHI SATISH	Wildlife Conservation
129	MUDE DIVYA SUDHAKAR	Environmental Ethics
130	PARIHAR SHREYA SUSHILSINGH	Renewable Energy
131	PATHADE MRUDULA PRAVIN	Marine Conservation
132	PHAD ANURADHA RAJABHAU	Water Conservation
133	PUSADKAR ANNADA VIVEK	Solar Panel and Water Turbines
134	RAMTEKE ROHANSHI SHESHRAJ	Human Impact on Forest
135	RATHOD SHALINI ANIL	Water Purification
136	RAUT RIYA TRILOKCHAND	Pollution, Pollution Control and Prevention
137	SAHARE JANVI RAJU	Climate Change
138	SHRIRAME FALGUNI SANDIP	Biodiversity
139	THAKARE KADAMBARI SANJAY	Recycling
140	TIDKE VAIBHAV WAMAN	Sustainability
141	UPASE VAIDEHI MANOHAR	Energy Conservation
142	WARHEKAR TWINKLE GOKUL	Environmental Economics
143	ALDAK NUPUR RAJENDRA	Wildlife Conservation
144	BADGE HRUSHIKESH KIRAN	Environmental Ethics
145	BHAKNE POONAM NIRANJAN	Renewable Energy
146	BHUTE JANVI SACHIN	Marine Conservation
147	CHANGOLE ANUSHKA DEVIDAS	Water Conservation
148	DALAL DHANASHREE VIKAS	Solar Panel and Water Turbines
149	DEOTALE SHRUTIKA DILIP	Human Impact on Forest
150	DESHMUKH TANVI RAJESH	Water Purification
151	DHAKATE KRUTIKA MAHESH	Pollution, Pollution Control and Prevention
152	GHADGE SIDDHANT RAMUJI	Climate Change
153	HEDYATULLAH SUHANA MD	Biodiversity
154	JOGANI ISHA SURAJ	Recycling

155	JUNGHARE SANCHIT SHESHRAO	Sustainability
156	KADU UNNATI UMESH	Energy Conservation
157	KAMDAR SURBHI NARESH	Environmental Economics
158	MALOT MUSKAN HUSEIN	Wildlife Conservation
159	MASRAM KHUSHBU DEVANAND	Environmental Ethics
160	NAGARE TANMAY PRADIP	Renewable Energy
161	PAIDLEWAR SALONI DINESH	Marine Conservation
162	PAIGAMI MEETALI RAJENDRA	Water Conservation
163	PATIL ANSHUL RAVINDRA	Solar Panel and Water Turbines
164	PRASAD SONAM RAMNATH	Human Impact on Forest
165	RALBANDIWAR UMARANI SANJAY	Water Purification
166	SINGH MUSKAN KUNDAN KUMAR	Pollution, Pollution Control and Prevention
167	THAKUR SHRUSHTI DEEPAKSINGH	Climate Change
168	UPARKAR JUEE VILAS	Biodiversity
169	WALDE DURGA RAJU	Recycling
170	WANKHEDE JUHI MANOJ	Sustainability
171	ADROKAR TULNA DILIP	Energy Conservation
172	AGNIHOTRI DEVESH MAHESH	Environmental Economics
173	ALAM ALIYA MD AFTAB	Wildlife Conservation
174	ALONE KHUSHI PRABHUDAS	Environmental Ethics
175	AMBOLIKAR ISHIKA MANISH	Renewable Energy
176	BAGDE DIYA DEEPAK	Marine Conservation
177	BAGHEL UMAKANTI JAGMOHAN	Water Conservation
178	BAISWARE ADITYA RAJESH	Solar Panel and Water Turbines
179	BHAGAT ANURADHA ARUN	Human Impact on Forest
180	BHAISARE SEJAL SUSHIL	Water Purification
181	BHONGADE SNEHA MANISH	Pollution, Pollution Control and Prevention
182	BISEN MINAL SHANKAR	Climate Change
183	BORSE PRANALI ANIL	Biodiversity
184	CHADOKAR GARIMA WAMANRAO	Recycling
185	CHATAP PAYAL RAMRAO	Sustainability
186	DESHMUKH ROHINI VINOD	Energy Conservation
187	DHOLE MANJIRI ANIL	Environmental Economics
188	DORLE YASH SUNIL	Wildlife Conservation
189	DUTTA RAVEN SONI	Environmental Ethics
190	FULZELE SUHANI SAHADEO	Renewable Energy
191	GHAYWAT YASHASHREE SANJAY	Marine Conservation
192	GHORE VANUSHKA VINOD	Water Conservation
193	GUPTA MOHINI MAHENDRAKUMAR	Solar Panel and Water Turbines
194	HAWARE JAYESH ATUN	Human Impact on Forest
195	JAIWAL KASHISH MANOJ	Water Purification

196	JAISWAL SALONI SATISH	Pollution, Pollution Control and Prevention
197	KALAMBE SHREYA GUNWANT	Climate Change
198	KASEKAR EKTA SANJAY	Biodiversity
199	MADAN DAKSHITA SANJAY	Recycling
200	MANAPURE TANUSHREE ROHIT	Sustainability
201	MOHADIKAR SHRUTI PURUSHOTTAM	Energy Conservation
202	NAHATE ASHWINI RAVI	Environmental Economics
203	SANIKA RAHUL KASHIKAR	Human Population and Environment
204	RAUT SRUSHTI BHIMRAO	Environmental Ethics
205	SAMRIT SMITA ARVIND	Renewable Energy
206	SARODE PRACHI DHARMENDRA	Marine Conservation
207	SATHAWANE MRUNMAYEE PRAMOD	Water Conservation
208	SHENDE BHAGYSHREE VILAS	Solar Panel and Water Turbines
209	SHENDE MRUDUL RAHUL	Human Impact on Forest
210	SHENDE SHRAVANI RAMESH	Water Purification
211	SHINDE AKANSHA VIJAY	Pollution, Pollution Control and Prevention
212	SINGH SHIPRA PAWAN	Climate Change
213	TODASE ISHIKA SUBHASH	Biodiversity
214	WALKE DEVYANI RATNAKAR	Recycling
215	ZADGAONKAR AVANTI ANIRUDHA	Sustainability
216	ZUNZUNKAR TANUSHREE RAMBHAU	Energy Conservation
217	ATILKAR PRANAY DNYANESHWAR	Renewable Energy
218	BAGDE YASHIKA PRAMOD	Marine Conservation
219	BARDE VISHA PRAKASH	Water Conservation
220	BHOYAR HEMAD AJAY	Solar Panel and Water Turbines
221	BHUSHANWAR MRUNALI NARESH	Human Impact on Forest
222	BISEN KAJAL DEBILAL	Water Conservation
223	BOLE ANCHAL ANOOP	Solar Panel and Water Turbines
224	BONDRE TITHI KUSUMAKAR	Human Impact on Forest
225	BORKAR DUSHANT RUSHI	Water Purification
226	CHAVHAN AYUSH DILIP	Pollution, Pollution Control and Prevention
227	CHIKHALKAR HARSHADA WASUDEV	Climate Change
228	CHOUDHARI BHARVI VIKAS	Biodiversity
229	DALVI CHETNA KAILAS	Recycling
230	GAJBHIYE ARPITA KISHOR	Sustainability
231	GUJWAR KHUSHBU PURANSINGH	Energy Conservation
232	HIWARKAR RAUNAK KRISHNA	Environmental Economics
233	ISHWARKAR KANIKA YOGRAJ	Wildlife Conservation
234	JIWANE GRECY CHANDU	Environmental Ethics
235	JOSHI ARYAN SHRIPAD	Renewable Energy
236	KADAMDHAD MAYUR YOGESHWAR	Marine Conservation

237	KALAMKAR SHRAVANI MADHUKAR	Water Conservation
238	KAMBE ARPIT AVINASH	Solar Panel and Water Turbines
239	KAMBLE KOMAL SANJAY	Human Impact on Forest
240	KAWDE KHUSHI RAJU	Water Purification
241	KHOT SAMIKSHA GHANSHYAM	Pollution, Pollution Control and Prevention
242	KOTHALKAR AWANTI SAHEBRAO	Climate Change
243	KULTHE SNEHA PAWAN	Biodiversity
244	Tanvi Samarth	Recycling
245	Humera Afroz	Sustainability
246	Mayur Kadhadhad	Energy Conservation
247	Sakshi Vaidya	Environmental Economics
248	Sanika Zade	Wildlife Conservation
249	Mitali Thakare	Environmental Ethics
250	Yash Wasnik	Renewable Energy
251	Khushi Singh	Marine Conservation
252	Harshal Upadhya	Water Conservation
253	MADAN MOKSHITA HARISH	Solar Panel and Water Turbines
254	MANKAR MAITREYEE KISHOR	Human Impact on Forest
255	MATE SHREYA SUDHAKAR	Water Purification
256	MORE DHANASHREE DEEPAK	Pollution, Pollution Control and Prevention
257	PANDEY DURGESH GOKUL	Climate Change
258	PANDEY ISHIKA AMARNATH	Biodiversity
259	PANDEY VISHAKHA SURENDRA	Recycling
260	PAWADE PRADNYA PURUSHOTTAM	Sustainability
261	RAMTEKE ISHITA CHANDRASHEKHAR	Energy Conservation
262	RAUT NEHA BABURAO	Environmental Economics
263	RAUT SALONI GIRISH	Wildlife Conservation
264	RAUT SANIKA DILIP	Environmental Ethics
265	ROHANKAR RIYA MUKESH	Renewable Energy
266	SAMARTH TANVI YASHWANT	Marine Conservation
267	SHARMA KANIKA GANGA	Water Conservation
268	SHEIKH HUMERA AFROZ NASIR	Solar Panel and Water Turbines
269	SINGH KHUSHI PRAKASH	Human Impact on Forest
270	SONARKAR NEHA SANJAY	Water Purification
271	SONKULE ROMI VILAS	Pollution, Pollution Control and Prevention
272	THAKRE MAITHILI NARESH	Climate Change
273	TINKHEDE AISHWARYA SUNIL	Biodiversity
274	TIWARI ACHAL ANUJ	Recycling
275	UPADHYE HARSHAL DILIP	Sustainability
276	VAIKAR SAKSHI SHANKARRAO	Energy Conservation
277	WAKDE NITESH SIDDHARTH	Environmental Economics

278	WAKULKAR VEDANTI DINESH	Wildlife Conservation
279	WASNIK ASHIT NARESH	Environmental Ethics
280	WASNIK GUNGUN LAXMAN	Renewable Energy
281	WASNIK YASH PRAMOD	Marine Conservation
282	YADAV MAMTA SANTOSH	Water Conservation
283	ZADE SANIKA CHANDRASHEKHAR	Solar Panel and Water Turbines
284	BAGHELE AARTI OMSHANKAR	Human Impact on Forest
285	BHONDGE KUNALI SATISH	Water Purification
286	BOMBARDE SHREYA VIJAY	Pollution, Pollution Control and Prevention
287	CHOUDHARI NANDINI DINKAR	Climate Change
288	DHOKE SANJANA ANKUSH	Biodiversity
289	DHUDSE ADITYA RITESH	Recycling
290	KALE SUMATI SANJAY	Sustainability
291	KHARE JATIN SURESH	Energy Conservation
292	KOSEKAR KOMAL KISANA	Environmental Economics
293	MEHAR HIMANSHI VIJAY	Wildlife Conservation
294	NANDANWAR SALONI ARUN	Environmental Ethics
295	NEMADE RAM ARUN	Renewable Energy
296	RAUT MOHINI MANOHAR	Marine Conservation
297	SAWARKAR SWAYAM KISHOR	Water Conservation
298	UIKEY KRITIKA YOGESH	Solar Panel and Water Turbines
299	WAHALE PRESHIT RAJESH	Human Impact on Forest
300	MOHAMMED SAHIL ANWAR MOHD SADIQUE MOTIWALA	Water Purification
301	BANSOD ANJALI VISWAS	Pollution, Pollution Control and Prevention
302	BEDADE MANISHA JANARDAN	Climate Change
303	BOPCHE PAYAL NANDKISHOR	Biodiversity
304	KAMBLE SAYALI CHANDRAPAL	Recycling
305	MANWATKAR AAHAN DEEPAK	Sustainability
306	NARNAWARE SAKSHI ANIL	Energy Conservation
307	NIMJE ARNIKA SUSHILKUMAR	Environmental Economics
308	RAMTEKE HITALI PADMAKAR	Wildlife Conservation
309	RANGARI YASHIKA SUSHIL	Environmental Ethics
310	UIKE VIDYA MAROTRAO	Renewable Energy
311	UIKEY GAYATRI TEJRAM	Marine Conservation
312	WAHANE KOMAL DEVANAND	Water Conservation
313	ADHAU PURVA PRAMOD	Solar Panel and Water Turbines
314	CHAUDHARI DURGESHWARI RAMPRASAD	Human Impact on Forest
315	DHORE SADICHCHHA DILIP	Water Purification
316	GUPTA KSHITIJ ADITYASHEKHAR	Pollution, Pollution Control and Prevention
317	HAJARE POOJA RAJU	Climate Change
318	INGLE NISHCHAL SHILPA	Biodiversity

319	JANGLE VAISHANAVI ROSHAN	Recycling
320	KUNDARPAWAR ARYA VIKAS	Sustainability
321	MASKHARE MAYUR PRASHANT	Energy Conservation
322	MESHARAM MASUM SUDHAKAR	Environmental Economics
323	PALANDURKAR ANUSHKA AMAR	Wildlife Conservation
324	PATIL ROHIT SACHIN	Environmental Ethics
325	PAWAR SUMAN SHEMEKHIL	Renewable Energy
326	SHEIKH MANTESHA TABASSUM ALTAF	Marine Conservation
327	TUPAT MAYURI RAJESH	Water Conservation
328	WUIKEY ARYA ARUN	Solar Panel and Water Turbines
329	AMBULKAR PRANJAL RAJESH	Human Impact on Forest
330	ANSARI MUGHEES UR SHAFIQR RAHMAN	Water Purification
331	ARVERKAR AACHAL RAJNAND	Pollution, Pollution Control and Prevention
332	ATRAHE KARINA PARASRAM	Climate Change
333	BADGE KARTAVYA PRAKASH	Biodiversity
334	BADKHAL SHWETA BALKRUSHNA	Recycling
335	BAGADE TUSHAR BHAUJI	Sustainability
336	BAMBAL KARTIK SUDHAKAR	Energy Conservation
337	BANSOD MAI RAMDAS	Environmental Economics
338	BARDE PRACHI DNYANESHWAR	Wildlife Conservation
339	BHASMOTE MAHIMA RAJENDRA	Environmental Ethics
340	BHEDE SAHIL GANESH	Renewable Energy
341	BHUJADE PRATIK TULSHIRAM	Marine Conservation
342	BORKAR NAYANI SUNIL	Water Conservation
343	BURDE SARANG NARENDRA	Solar Panel and Water Turbines
344	CHICKHEDE SAYYAM SHYAMKUMAR	Human Impact on Forest
345	DEDHE TANVI RAJEEV	Water Purification
346	DESHMUKH SHRAVANI VINOD	Pollution, Pollution Control and Prevention
347	DHOTE SANCHALI RAMKRUSHNA	Climate Change
348	DUBEY AYUSH RAJESH	Biodiversity
349	FARUKI REHAN SHAHEJAD	Recycling
350	GAIKWAD HARSH HARISH	Sustainability
351	GEDAM PRANAY VAISRAJ	Energy Conservation
352	GHUMARE RUPESH RAJENDRA	Environmental Economics
353	GOKHE PAWANKUMAR RAMKISHOR	Wildlife Conservation
354	GUHE SIDDHESH SUBHASH	Environmental Ethics
355	HEDAU CHETNA SUNIL	Renewable Energy
356	HULKE PRACHI MAHESH	Marine Conservation
357	JAULKAR TANUSHREE RAM	Water Conservation
358	KATRE PRANJALI CHANDRAKANT	Solar Panel and Water Turbines
359	KHANDARE NANDINI VIJAYRAO	Human Impact on Forest

360	KHANDEKAR PIYUSH CHANDRAMANI	Pollution, Pollution Control and Prevention
361	KHARABE YASH PRAVIN	Climate Change
362	KOKATE MANAS SHAILENDRA	Biodiversity
363	KSHIRSAGAR HARSH ASHISH	Recycling
364	KUHITE KRUNAL AJAY	Sustainability
365	MAHAMUNE ALKESH ARUN	Energy Conservation
366	MALGHATE TANMAY PREMGOPAL	Environmental Economics
367	MANE ADITYA KAILAS	Wildlife Conservation
368	MASRAM ANURAG GANESH	Environmental Ethics
369	MESHARAM RUCHIKA SHANKAR	Renewable Energy
370	MESHARAM VAIBHAVI CHANDRASHEKHAR	Marine Conservation
371	NAKSHANE SAMIKSHA NARENDRA	Water Conservation
372	PANDEY PRITI BIJENDRA	Solar Panel and Water Turbines
373	PARDHI KHUSHEE UDELAL	Human Impact on Forest
374	PATLE TRUPTI ASHOK	Water Purification
375	PATRE NITESH NEHARULAL	Pollution, Pollution Control and Prevention
376	PAWAR AYUSH BABAN	Climate Change
377	RAJGE SNEHAL RAVINDRA	Biodiversity
378	RAMTEKE SHRUSTI RAJESH	Pollution, Pollution Control and Prevention
379	SANAP VIKAS NAMDEO	Climate Change
380	SHAHARE PUJAN SANJAY	Biodiversity
381	SHARNAGATE ARCHANA TEJRAM	Recycling
382	SONBARSE YASH NARESH	Sustainability
383	TAMBULKAR PUSHPAK ANIL	Energy Conservation
384	TEMBHARE DEVASHISH SANTOSHKUMAR	Environmental Economics
385	THAKRE ISHWESHWARI RAJENDRA	Wildlife Conservation
386	THAWARE NAMRATA PRAMOD	Environmental Ethics
387	WARATKAR NIKITA SATISH	Renewable Energy
388	WASNIK ANURAG RAJESH	Marine Conservation
389	YADAV SHLOK CHANDAN	Water Conservation
390	YEKUDE TEJASWINI PUNDLIK	Solar Panel and Water Turbines
391	ZADE ANUJA VILAS	Human Impact on Forest



Dr. P.B.Zamarkar(Convener)

SHIVAJI SCIENCE COLLEGE, CONGRESS NAGAR, NAGPUR

ENVIRONMENTAL STUDIES

Session 2023-2024

The environment encompasses everything around us, from the air we breathe to the ecosystems that support life on Earth. It's a complex system of interconnected elements, including natural resources, climate patterns, biodiversity, and human activities. Protecting the environment is crucial for sustaining life and ensuring the well-being of present and future generations. This involves conservation efforts, sustainable resource management, reducing pollution, and mitigating the impacts of climate change.

Environmental studies help us comprehend the intricate interactions between living organisms and their surroundings. This knowledge is crucial for maintaining biodiversity and ensuring the sustainability of ecosystems. Environmental studies play a vital role in addressing climate change. Through research and analysis, we can develop strategies to mitigate greenhouse gas emissions, adapt to changing climatic conditions, and protect vulnerable communities and ecosystems from the impacts of global warming. Environmental studies raise awareness about the importance of conserving and preserving natural habitats and endangered species. By understanding the value of biodiversity and ecosystems services, we can work towards protecting fragile environments and preventing species extinction. Environmental studies are essential for fostering a deeper understanding of the natural world and promoting the conservation and sustainable use of Earth's resources for the benefit of present and future generations.

ENVIRONMENTAL STUDIES : FOR B.Sc – II and BCA-II

Teaching Methodologies

The core Module Syllabus for Environment Studies includes class room teaching and Field Work. The syllabus is divided into eight units covering 50 lectures. The first seven units will cover 45 lectures which are class room based to enhance knowledge skills and attitude to

environment. Unit eight is based on field activities which will be covered in five lecture hours and would provide student first hand knowledge on various local environmental aspects. Field experience is one of the most effective learning tools for environmental concerns. This moves out of the scope of the text book mode of teaching into the realm of real learning in the field, where the teacher merely acts as a catalyst to interpret what the student observes or discovers in his/her own environment. Field studies are as essential as class work and form an irreplaceable synergistic tool in the entire learning process. Course material provided by UGC for class room teaching and field activities be utilized.

Annual System : The duration of the course will be 50 lectures. The exam will be conducted along with the Annual Examination.

Semester System : The Environment course of 50 lectures will be conducted in the second semester and the examination shall be conducted at the end of the second semester.

Exam Pattern : The question paper should carry 100 marks. The structure of the question paper being :

Part-A, Objective Question	-	50 marks	Part-
B, Essay type question	-	25 marks	Part-
C, Field Work(Project)	-	25 marks	

During academic year 2022-2023 environmental studies organized 4 days educational visit to college campus and nearby area from dated 25-28 October 2023 for B.Sc and BCA II year students. Per day each batch will be taken for the campus visit.

Environmental Studies Educational Visit Report:

The Environmental Studies department of Shri Shivaji Science College organized a four-day educational visit from October 25 to 28, 2023, aimed at providing students with practical exposure to environmental issues, conservation efforts, and sustainable practices. The visit encompassed the college campus and nearby areas of Nagpur to foster a deeper understanding of environmental dynamics

Day 1: Exploration of College Campus On the first day, students gathered at the college campus where they were briefed about the itinerary and objectives of the visit. Guided by faculty members, students embarked on a comprehensive tour of the campus, focusing on its biodiversity, green spaces, and sustainable infrastructure. They learned about the various flora and fauna present on campus and the initiatives taken by the college to promote environmental conservation, such as recycling programs and energy-efficient facilities.

Day 2: Field Trip to Nearby Nature Reserves. The second day of the educational visit involved a field trip to nearby nature reserves and conservation areas. Students had the opportunity to observe local ecosystems firsthand, including forests, wetlands, and riverbanks. Guided nature walks and interactive sessions with park rangers provided students with insights into the importance of biodiversity, habitat conservation, and the challenges faced by these ecosystems. They also participated in activities such as birdwatching and plant identification exercises.

Day 3: Community Engagement and Awareness The third day focused on community engagement and awareness-building activities. Students visited local communities residing near the college campus to learn about their environmental concerns and initiatives. Interactive discussions and workshops were conducted to raise awareness about sustainable practices, waste management, and the importance of preserving natural resources. Students actively participated in community cleanup drives and tree-planting activities, fostering a sense of environmental responsibility and civic engagement.

Day 4: Reflection and Conclusion On the final day of the educational visit, students engaged in reflection sessions facilitated by faculty members. They shared their experiences, insights, and lessons learned throughout the four-day excursion. Group discussions centered on identifying ways to implement sustainable practices within the college campus and contribute to local environmental conservation efforts. The visit concluded with a closing ceremony where students were recognized for their active participation and commitment to environmental stewardship.

The four-day educational visit to explore the college campus and nearby areas proved to be an enriching experience for students, providing them with valuable insights into environmental issues and conservation efforts. Through hands-on activities, interactive sessions, and community engagement initiatives, students not only deepened their understanding of

environmental concepts but also developed a sense of responsibility towards safeguarding the environment. Such initiatives play a crucial role in nurturing environmentally conscious individuals who can contribute positively to society and address the challenges of sustainability.



Dr. P.B.Zamarkar

Convener

21/10/2023

To,
The Principal,
Shivaji Science College,
Congress Nagar, Nagpur.

Subject: Permission for field visit in the College Campus for Environmental studies students (Four days).

Respected Sir,

We wish to inform you that we have organized an educational field visit to College campus and nearby area from dated 25-28 October 2023 for B.Sc. and BCA II year students. Per day each batch will be taken for the campus visit. This tour is organized under the environmental studies compulsory subject for B.Sc. and BCA - II year students. There will be two teachers for accompanying.

We humbly request you to kindly give permission to take the Environmental studies students to visit above mention place.

Thanking You

Permitted
M. Shinde

Your Faithfully,

Dr. P. B. Zamarkar

Dr. R. S. M. Walhar

M. Shinde
Walhar

Sri Sri Sai Education Society, Amravati's Science College, Congress Nagar, Nagpur.
ENVIRONMENTAL STUDIES EXAMINATION (2023 - 2024)
 Class :- B.C.A - II (H.K. IV Sem)
Project Submission

Sr. No	Roll	Signature
1	ANBULIAR FRANJAL RAJESH	
2	ANSARI MUGHEES UR SHAFIQUR RAHMAN	
3	ARVERKAR AACHAL RAJNAND	
4	ATRAHE KARINA PARASHRAM	
5	BADGE GARIVYA PRAKASH	
6	BADHIAL SHWETA BALKRUSHNA	
7	BAGADI TUSIAR BHAIJI	
8	BANSAL KATEER SUDHAKAR	
9	BANSODI NAITRANJAN	
10	BANDE PRACHI DNYANESHWARI	
11	BHASKAROTE SHARIMA RAJENDRA	
12	BHEDDE SAHIL GANESH	
13	BHILUSI SHRIK TILASHRAM	
14	BHOKAR NAYAN SUNIL	
15	BURDE SARANG NARENDRA	
16	CHAUDHARI VASHALI MADHUKAR	
17	CHAUDHRI MAHJAB ASHOKRAO	
18	CHICHKHEDE SAYRAM SHYAMKUNJI	
19	CHODHARY SAHIL RAJENDRA	
20	DAT NARAYAN RAM	
21	DEKHE TAVVI RAJEEV	
22	DESHMUKHI SHRAVANI VINDO	
23	DHALE TRITIKAL SANJAY	
24	DHOTI SANDHAI RAMKRUSHNA	
25	DUDHY AYUSHI RAJESH	
26	DUPANE SAMIKSHA PRAKASH	
27	FARUKI DEHAN SHAHEJAD	
28	GADHARE JUMANSHU YASHWANT	
29	GAIKWAD HARSH HARSH	
30	GAIKWAD SAURABH GANESH	
31	GAWDE SHARDEUL SUDHIL	
32	DEWAN PRANAY VIKRANT	
33	GHATE CHHUSHI ASHOK	
34	GHUMARE ROJESH RAJENDRA	
35	GHATE PAVANRAJENDRA RAMKISHOR	
36	GONDHARE KALASHI SUKRAM	
37	GUNE SIDDHESH SUDHAKAR	

- 29 - Ab

Shri Chaitanya Education Society's Yashwantrao Chavan College, Chhatrapati Sastri
 ENVIRONMENTAL STUDIES EXAMINATION (2021 - 2022)
 Group: BUA - III, III & IV SEM

Sl. No.	Roll No.	Student's Full Name	Signature
1	50	ABHIRAM PRADIP DADAR	<u>P. Subha</u>
2	51	ADARSH ANILKUMAR KADAM	<u>A. S.</u>
3	52	ADITHYAN ANILKUMAR KADAM	<u>Anil</u>
4	53	ADITHYAN ANILKUMAR KADAM	<u>Adarsh</u>
5	54	ADITHYAN ANILKUMAR KADAM	<u>Adarsh</u>
6	55	ADITHYAN ANILKUMAR KADAM	<u>Adarsh</u>
7	56	ADITHYAN ANILKUMAR KADAM	<u>Adarsh</u>
8	57	ADITHYAN ANILKUMAR KADAM	<u>Adarsh</u>
9	58	ADITHYAN ANILKUMAR KADAM	<u>Adarsh</u>
10	59	ADITHYAN ANILKUMAR KADAM	<u>Adarsh</u>
11	60	ADITHYAN ANILKUMAR KADAM	<u>Adarsh</u>
12	61	ADITHYAN ANILKUMAR KADAM	<u>Adarsh</u>
13	62	ADITHYAN ANILKUMAR KADAM	<u>Adarsh</u>
14	63	ADITHYAN ANILKUMAR KADAM	<u>Adarsh</u>
15	64	ADITHYAN ANILKUMAR KADAM	<u>Adarsh</u>
16	65	ADITHYAN ANILKUMAR KADAM	<u>Adarsh</u>
17	66	ADITHYAN ANILKUMAR KADAM	<u>Adarsh</u>
18	67	ADITHYAN ANILKUMAR KADAM	<u>Adarsh</u>
19	68	ADITHYAN ANILKUMAR KADAM	<u>Adarsh</u>
20	69	ADITHYAN ANILKUMAR KADAM	<u>Adarsh</u>
21	70	ADITHYAN ANILKUMAR KADAM	<u>Adarsh</u>
22	71	ADITHYAN ANILKUMAR KADAM	<u>Adarsh</u>
23	72	ADITHYAN ANILKUMAR KADAM	<u>Adarsh</u>
24	73	ADITHYAN ANILKUMAR KADAM	<u>Adarsh</u>
25	74	ADITHYAN ANILKUMAR KADAM	<u>Adarsh</u>
26	75	ADITHYAN ANILKUMAR KADAM	<u>Adarsh</u>
27	76	ADITHYAN ANILKUMAR KADAM	<u>Adarsh</u>
28	77	ADITHYAN ANILKUMAR KADAM	<u>Adarsh</u>
29	78	ADITHYAN ANILKUMAR KADAM	<u>Adarsh</u>
30	79	ADITHYAN ANILKUMAR KADAM	<u>Adarsh</u>
31	80	ADITHYAN ANILKUMAR KADAM	<u>Adarsh</u>
32	81	ADITHYAN ANILKUMAR KADAM	<u>Adarsh</u>
33	82	ADITHYAN ANILKUMAR KADAM	<u>Adarsh</u>
34	83	ADITHYAN ANILKUMAR KADAM	<u>Adarsh</u>
35	84	ADITHYAN ANILKUMAR KADAM	<u>Adarsh</u>
36	85	ADITHYAN ANILKUMAR KADAM	<u>Adarsh</u>
37	86	ADITHYAN ANILKUMAR KADAM	<u>Adarsh</u>
38	87	ADITHYAN ANILKUMAR KADAM	<u>Adarsh</u>
39	88	ADITHYAN ANILKUMAR KADAM	<u>Adarsh</u>
40	89	ADITHYAN ANILKUMAR KADAM	<u>Adarsh</u>
41	90	ADITHYAN ANILKUMAR KADAM	<u>Adarsh</u>

A-2 P(106)

40	KU	HULKE FRACHI MAHESH		
41	KU	JALIKAR TANUSHREE RAM	<u>Rahulke</u>	
47		KAMBLE DARSHAN SUDESH	<u>Rajaulkar</u>	
43		KAPSE EXNATH VIJAY	<u>Bamble</u>	
44	KU	KATRE PRANJALI CHANDRAKANTI		<u>E. Kapse</u>
45	KU	KHANDARE NANDINI VIJAYRAG	<u>Florie</u>	
46	KU	KHANDATE VANSHIKA ARUN	<u>N. Khondosi</u>	
47		KHANDIKAR PIYUSH CHANDRAMANI	<u>Obhandate</u>	
48		KHAN MOIN ABDUL WAHID	<u>DKR</u>	
49		KHARABE YASH PRAVIN		<u>M. Khan</u>
50		KHOKATE MANAS SHAILENDRA		<u>Ucherrabe</u>
51	KU	KOLHE KAR TANUSHREE RIMVATH	<u>M. Kolate</u>	
52		KSHIRSAGAR HARSH ASHISH	<u>Harsh</u>	
53		KUHTE KRUNAL AJAY	<u>Jugal</u>	
54	KU	LATKAR AISHWARYA NAMDEV	<u>Anakasa</u>	
55		MACHAMUNE ALKESH ARUN	<u>Machamune</u>	
56		MALHOTRE TANMAY PRITMOGPAI	<u>Pritya</u>	
57	KU	MALHOTRE TULSI UMARANI	<u>Malhotre</u>	
58		MARDE ADITYA KAILAS	<u>Smruti</u>	
59		MASHRAM ANURAG GANESH		<u>Anurag</u>
60	KU	MISHRAM RUCHIRA SHANIKAR	<u>P. Mishram</u>	
61	KU	MISHRAM VIBHAVI	<u>Vishram</u>	
62		MISHRA ANURAG HARISHKUMAR		<u>Anurag</u>
63	KU	NAGPURE PRANALI PRABHAKAR	<u>Becorelli</u>	
64	KU	NARSHANI SAMRISHA NARENDR	<u>Sa</u>	
65	KU	PALWE YASHASHRITI HAMESHRAG	<u>P. Palwe</u>	
66		PANDEY ANUPAM RAJESH	<u>A. Pandey</u>	
67	KU	PANDEY PREETI BHENDRA		<u>P. Pandey</u>
68	KU	PANDEY KHUSHI UDEPAL	<u>Khushi</u>	
69	KU	PANDEY GOMAL KAILASH		<u>K. Pandey</u>
70	KU	PATEE TRIPATI ASHOK		<u>Trish</u>
71	KU	PATEE VABHAVI DHARPAL	<u>Trish</u>	
72		PATEE NITESH NERANDEAL	<u>Nitesh</u>	
73		PAWAR AYUSH BABAN	<u>Pa</u>	
74	KU	PISH RAJEEV MANOJRAG		
75		RAJANE DILEE GAURAV LAXMICHAND	<u>Gaurav</u>	
76	KU	RANGI SNEHA RAVINDRA	<u>Rangi</u>	
77	KU	RAUT REE SHRUTI RAJESH	<u>Raut</u>	
78	KU	RAUT RISHITA ASHOK	<u>R.A. Raut</u>	
79		SADARE SARVI SH RAMESH	<u>Sh</u>	
80		SANAP VIRAS NAMDIL		
81	KU	SANTHOGI PUJAN SANJAY	<u>Sholara</u>	
82	KU	SETHURAMANI ARCHANA TEJARAM		

83	Ku	SHINDE AKANKSHA AJAYKUMAR
84		SONBARSE YASH NARESH
85	Ku	TAKALKHEDE HARSHALI ASHOK
86	Ku	TAMBULKAR PUSHPAK ANIL
87		TARLAKAR AAYUSH RAJENDRA
88		TEMBHARE DEVASHISHI SANTOSH KUMAR
89	Ku	THAKRE ISHWESHWARI RAJENDRA
90	Ku	THYWARE NAMRATA PRAMOD
91		TITOKAL ABHISHIK SANJAY
92		THORAT OM PANKAJ
93	Ku	TURKAR TANVI DINESH
94	Ku	TUMARE RAJAL ASHOK
95	Ku	VAIDYA NISHA VIJAY
96	Ku	WAGHSHIRKAYA LADHU
97		WANKHEDDE TIJAS DNYARESHWAR
98	Ku	WARATKAR NIKITA SATISH
99		WASNIK ANURAG RAJESH
100	Ku	WASNIK SNEHA SANJAY
101	Ku	WALE SARDANA VINDI
102		YADAV SHILOK CHANDAN
103		YERUDE ANSHU GUNWANT
104	Ku	YERUDE TEJASWINI PUNDLIK
105	Ku	YENKAR LEENA MURLIDHAR
106	Ku	ZAYE APARAJITA VILAS

~~Shinde~~
Y.N.Soni
Lij

~~Musthafa~~

~~Pambolke~~

~~DS~~

~~Thakre~~

~~Thaware~~

~~Thakre~~

~~Thakre~~

Additional ~~ABSENT~~ - 7620522314

N.v.vaidya
Shirish

~~Twankhede~~

~~Waratkar~~

~~Wasnik~~

~~Wasnik~~

~~Wale~~

~~Wale~~

~~Yadav~~

~~Yerude~~

~~Yenkar~~

~~Zaye~~

Dur
Present - 97
Absent - 29
106

Sign. of invigilator

Anandi V. Bansinge 3/1/21

Ritika. M. Ganvir ~~Ganvir~~

Rasika D. Bagal ~~Bagal~~

Sheelika V. Lokhande - 3/1/21

Shri Shivaji Education Society Amravati's Science College, Congress Nagar, Nagpur.
 ENVIRONMENTAL STUDIES EXAMINATION (2023 - 2024)
 Class :- B. Sc. - II (III & IV Sem)
 Subject :- CZM Section :- C Batch :- B - I

Sr. No	Roll	Students Full Name
1	Ku	AYYAGARI RENUKA SUDHAKAR
2	Ku	BANHE SHRADDHA GUDDU
3	Ku	BEHAR KHUSHI RAJU
4	Ku	BHAISARE CHETANA DINESH
5	Ku	BHIMTE SHRIYA SURENDRAKUMAR
6	Ku	CHOUDHARY VAISHNAVI
7	Ku	CHANDRAKANTI
8	Ku	GANVIR ANUSHKA ANIL
9	Ku	GOSWAMI DIVYA VIKAS
10	Ku	GOSWAMI LAXMI KISHOR
11	Ku	GUPTA SHREYA RAVINDRA
12	Ku	KALE MRUNALI CHANDRAJEET
13	Ku	KOLHE HARSHINI ARVIND
14	Ku	LONDE HARSHADA RAJESH
15	Ku	MOHOD SAMRUDDHI SATISH
16	Ku	MUDE DIVYA SUDHAKAR
17	Ku	PARIHAR SHREYA SUSHILSINGH
18	Ku	PATHADE MRUDULA PRAVIN
19	Ku	PHAD ANURADHA RAJABHAU
20	Ku	PUSADKAR ANNADA VIVEK
21	Ku	RAMTEKE ROHANSHI SHESHRAJ
22	Ku	RATHOD SHALINI ANIL
23	Ku	RAUT RIYA TRILOKCHAND
24	Ku	SAHARE JANVI RAJU
25	Ku	SHRIRAME FALGUNI SANDIP
26	Ku	THAKARE KADAMBARI SANJAY
27	Ku	TIDKE VAIBHAV WAMAN
28	Ku	UPASE VAIDEHI MANDHAR
	Ku	WARHAKAR TWINKLE GOKUL
		Due
		Present
		Absent
		Sign. of Invigilator

Addmission card

8767065527

A. Panuka.
Bans.

ABSENT

Bhaisare
Bhimte

Choudhary

Chandrakanti
Ganvir

Goswami

Goswami
Gupta

Kale

Kolhe

Londe
Mohod

Mude
Parihar

Pathade

Phad
Pusadkar

Ramteke

Rathod
Raut

Sahare

Shrirame

Thakare
Tidke

Upase
Warhakar

27

01

Janvi
27/04/24

Shri Shivaji Education Society Amravati's Science College, Congress Nagar, Nagpur.
ENVIRONMENTAL STUDIES EXAMINATION (2023 - 2024)

Class :- B. Sc. - II (III & IV Sem)

Subject :- CBZ. Section :- C Batch :- B-4

Sr. No	Roll	Students Full Name
1		HAWARE JAYESH ATUN
2		JAISWAL KASHISH MANOJ
3	Ku	JAISWAL SALONI SATISH
4	Ku	KALAMBE SHREYA GUNWANT
5	Ku	KASLAKAR EKTA SANJAY
6	Ku	MADAN DAKSHITA SANJAY
7	Ku	MANAPURE TANUSHREE ROHIT
8	Ku	MOHADIKAR SHRUTI PURUSHOTTAM
9	Ku	NAHATE ASHWINI RAVI
10	Ku	RAUT SANIKA VILAS
11	Ku	RAUT SRUSHTI BHIMRAO
12	Ku	SAMRIT SMITA ARVIND
13	Ku	SARODE PRACHI DHARMENDRA
14	Ku	SATHAWANE MRUNMAYEE PRAMOD
15	Ku	SHENDE BHAGYSHREE VILAS
16	Ku	SHENDE MRUDUL RAHUL
17	Ku	SHENDE SHRAVANI RAMESH
18	Ku	SHINDE AKANSHA VIJAY
19	Ku	SINGH SHIPRA PAWAN
20	Ku	TODASE ISHIKA SUBHASH
21	Ku	WALKE DEVYANI RATNAKAR
22	Ku	ZADGAONKAR AVANTI ANIRUDHA
23	Ku	ZUNZUNKAR TANUSHREE RAMBHAU
		Due
		Present
		Absent
		Sign. of Invigilator

Haware
Jaiswal
Jaiswal
Kalambe
Kasalkar
Madan
Manapure
Mohadikar
Nahate
Raut
Raut
Samrit
Sarode
Sathawane
Shende
Shende
Shende
Shinde
Singh
Todase
Walke
Zadgaonkar
Zunzunkar

23
00

P. Pawar
27/4/24

Shri Shivaji Education Society Amravati's Science College, Congress Nagar, Nagpur
 ENVIRONMENTAL STUDIES EXAMINATION (2023-2024)

Class :- B. Sc. - II (III & IV Sem)

Subject :- CMBI Section :- C Batch :- B-5

Sr. No	Roll	Students Full Name	
1	Ku	ANASANI VAIDHE GANESH	<u>Vganasane</u>
2	Ku	ANBOLE TRUPTI DNYANESHWAR	<u>Trupti</u>
3		ATILKAR PRANAY DNYANESHWAR	<u>Pratikar</u>
4	Ku	BAGDI YASHIKA PRAMOD	<u>Pragde</u>
5	Ku	BARDE VISHA PRAKASH	<u>Pravde</u>
6	Ku	BHOYAR HEMAD AJAY	<u>Pramad</u>
7	Ku	BHUSHANWAR MRUNALI NARESH	<u>Bhushanwar</u>
8	Ku	BISEN KAJAL DEBILAL	<u>Debilal</u>
9	Ku	BOLE ANCHAL ANOOP	<u>Anchal</u>
10	Ku	BONDE SHRUTI VINOD	<u>Shruti</u>
11	Ku	BONDRE TITHI KUSUMAKAR	<u>Tithi</u>
12		BORKAR DUSHANT RUSHI	<u>Dushant</u>
13	Ku	BRAMHANKAR SMRUTI SANJAY	Adclimia 020 Cell 7875887005
14		CHAVHAN AYUSH DILIP	<u>Ayush</u>
15	Ku	CHIDHAKAR HARSHADA WASUDEY	<u>Harshada</u>
16	Ku	CHOUDHARI BHARVI VIKAS	<u>Bharvi</u>
17	Ku	DALVI CHETNA KAILAS	<u>Chetna</u>
18	Ku	DHOBE RIYA SATISH	<u>Riya</u>
19	Ku	GAJBHIVE ARPITA KISHOR	<u>Arpita</u>
20	Ku	GHUGAL RUSHALI GHANSHYAM	<u>Rushali</u>
21	Ku	GUIWAR KHUSHBU PULANSINGH	<u>Khushbu</u>
22		HAKIM SHAFIN RAFIYODDIN	<u>Shafin</u>
23		HIWARKAR RAUNAK KRISHNA	<u>Raunak</u>
24	Ku	INGOLE NIKITA BANDU	<u>Nikita</u>
25	Ku	ISEWARKAR KANIKA YOGRAJ	<u>Kanika</u>
26	Ku	JAMBHULKAR KALSHIKA SUTISH	<u>Kalshika</u>
27	Ku	JIWANE GRECY CHANIDU	<u>Greacy</u>
28		JOSHI ARYAN SHRIPAD	<u>Aryan</u>
29		KADAMDHAD MAYUR YOGI SHWAR	<u>Mayur</u>
30	Ku	KALANIKAR SHRAVANI MADHUKAR	<u>Shravani</u>
31	Ku	KALE GAURIA TUL	<u>Gaure</u>
32	Ku	KAMBLE ARPIT AVINASH	<u>Arpita</u>
33	Ku	KAMBLE KOMAL SANJAY	<u>Komal</u>
34	Ku	KAWDE KHUSHI RAJU	<u>Khushi</u>
35	Ku	KEELAPURE SAI PRIYA RAMCHANDRA	<u>Sai Priya</u>

76	Ku	KHOT SAMIKSHA GHANSHYAM
77	Ku	KOTHALKAR AWANTI SAHEBRAO
78	Ku	KULTHE SNEHA PAWAN
		Due
		Present
		Absent

Sankha
Awanti
P. Kulthe

37
01

Sign. of Invigilator

S. Baghel

P(35) (11)

Shri Shivaji Education Society, Amravati's Science College, Congress Nagar, Nagpur.

ENVIRONMENTAL STUDIES EXAMINATION (2023 - 2024)

Class :- B. Sc. - II (III & IV Sem)

Subject :- CMBT Section :- C Batch :- B-6

Sr. No	Roll	Students Full Name
1	KU	KUTHE TEJAKSHI MAHI SHRIJAI
2	KU	MADAN LOKSHEJA HARISH
3	KU	MAHAR MANTREYEE KISHOR
4	KU	MAKASOLT NITRA PRADIPKUMAR
5	KU	MATE SHRIYA SUDHAKAR
6	KU	MAHAGATA DIVYAJIT KNATH
7	KU	MORE LILANASHIET DEEPAK
8	KU	NANWALE ASAVARI PRADHANAN
9		PANDEY DURGE SHIGOKUL
10	KU	PANDEY ISHIKA AMARNATH
11	KU	PANDEY USHAKHA SORENDR
12		PATILSHI SARDHAK RAJENDRA
13	KU	PAWANE PRADIPYA PUDUSHOTI LATA
14	KU	POUMBHAR SAKSHI RUSHALI
15		RAVSHAK YUGANTI LAKSHAN
16	KU	RAMTEK ISHITA CHANDRASHI KHAR
17	KU	RAUT NEHA RAJURAO
18	KU	RAUT SAJINI LALIT
19	KU	RAUT SAIJKA DILIP
20	KU	RUHANKAR RIZA MUKESH
		Due
		Present
		Absent

Kankshi
 Mahakata
 Manya
 Amalika
 Shrey
 Dhanu
 Amara
 Anas
 Ujjwal
 Chandey
 Veda
 Shikhar
 Pawade
 P. Pawar
 Nishik
 Raut
 Anas
 Raut
 Shantika

35
01

Sign. of invigilator



P-37

- 21) Aishwarya Suril Tinkhele
- 22) Tanvi Yashwant Samarth
- 23) Neha Sanjay Sonarkar
- 24) Maithili Naresh Thakre
- 25) Sakshi Shankar Vaikar
- 26) Humera Afroz
- 27) Romi Sonkule
- 28) Sanika Chandrashekar Zade
- 29) Yash P. Wasnik
- 30) Riya Rohankar
- 30) Nitesh Wakde
- 31) Namta Yadav
- (32) Harshal Upadhye
- (33) Vedanti D. Wakutkar
- (34) Kanika Ganga Sharma
- (35) Ashit Naresh Wasnik
- (36) Gungun Wasnik
- (37) Khushi Singh

- Alinika
- Samarth
- Namta
- Nwthakre
- Ashika
- TH
- Romi
- Sanika
- Wasnik
- Rohankar
- Nitesh
- Namta
- Harshal
- Vedanti
- Sharma
- Ashit
- Gungun
- Khushi
- Wasnik

Shri Shri Education Society - Amravati's Science College, Congress Nagar, Sangli
 ENVIRONMENTAL STUDIES EXAMINATION (2023 - 2024)
 Class - B.Sc. - III (III & IV Sem)
 Subject - CGM Section - D Batch - G-1

Sl. No	Roll	Students Full Name
1	Ku	BAGHELE MARTI OMSHANKAR
2	Ku	BHONDGE KUNALI SATISH
3	Ku	BOMBARDE SHREYANVIJAY
4	Ku	CHOUDHARI NANDINI DINKAR
5	Ku	DHARMIK DEVASHREE BHAIKRAO
6	Ku	DHOKI SANJANA ANKUSH
7		DHUDSE ADITYA RITESH
8	Ku	GUDADHE VINA DILIP
9	Ku	KALE SUMATI SANJAY
10		KHARLE JATIN SURESH
11	✓ Ku	KOSTKAR KOMAL KISANA
12	Ku	MEHAR HIMANSHI VIJAY
13	Ku	NANDANWAR SALONI ARUN
14		PHETADI RAM ARUN
15	Ku	PATELWANI SHARVARI MANIKRAO
16	Ku	RAUT MOHINI MANOHAR
17		SAWARKAR SWAYAM KISHOR
18	Ku	SHIRY KRITIKA YOGESH
19		WAHALE PRASHANT RAJESH
20	Ku	WANKAR NANDINI LAXMAN
21	Ku	WANKHEDDE SHEHAL SANJAY
		Due
		Present
		Absent
		19
		02
		Sign. of Invigilator

Santosh

Puradi

Shiray

Nandini

Devashree

S.A. Dhok

Aditya

Call nhi udhaga

Abxnt

9322426098

S.S. Kale

Kemal

Arjun

Saloni

Prashant

Shiray

M.M. Raut

Prashant

Prashant

Prashant

S.S. Wankhede

Arjun

Shri Shivaji Education Society Amravati's Science College, Congress Nagar, Nagpur.

ENVIRONMENTAL STUDIES EXAMINATION (2023 - 2024)

Class :- B. Sc. - II (III & IV Sem)

Subject :- CBG Section :- D Batch :- G - 2

Sr No	Roll	Students Full Name
1	KU	MOHAMMED SAHIL ANWAR MOHID SADIQUI MOTAWALA <i>Sahil</i>
2	KU	BARSOOD ANJALI VISWAS <i>Barsood</i>
3	KU	BEDADE MANISHA JANARDAN <i>Manisha</i>
4	KU	BOPCHE PAYAL NANDKISHOR <i>Payal</i>
5	KU	KAMBLE SAYALI CHANDRAPAL <i>Sayali</i>
6	KU	EDINARKAR JANHAVI PRAMOD <i>band hai</i> <i>absent</i>
7	KU	MANWATKAR AAHAN DEEPAK <i>absent</i>
8	KU	NAINAWARE SAKSHI AMIL <i>Sakshi</i>
9	<input checked="" type="checkbox"/>	NINGT. ANURTA SUSHIL KUMAR <i>Anurta</i>
10	KU	DAMATTE HITAJI PADMAKAR <i>Hitaji</i>
11	KU	WANGARI YASHIKA SUSHIL <i>Yashika</i>
12	KU	SALVE SAKSHI NITHE <i>Sakshi</i>
13	KU	MIRI VIDYA NARODTRAO <i>Virliya</i>
14	KU	AHREY GAYATHI BURAM <i>Gayathri</i>
15	KU	WAGHARE KOMAL DEVANAND <i>Rong Nahar</i> <i>absent</i>
		12
	Present	03
	Absent	
	Sign. of Investigator	<i>Ratni</i>

Shri Shivaji Education Society Amravati's Science College, Congress Nagar, Nagpur.
 ENVIRONMENTAL STUDIES EXAMINATION (2023-2024)

Class :- B. Sc. - II (III & IV Sem)

Subject :- PCC Section :- D Batch :- G - 3

Sr No Roll Students Full Name

1	KU	NEHA PURVA PRAMOD	<i>[Signature]</i>
2	KU	CHAUDHARI DURGESHWARI RAMPRASAD	<i>[Signature]</i>
3	KU	DHURE SADRICHHA DIIP	<i>[Signature]</i>
4	KU	GEDTA KSHITE ADITYASHRIKHALE	<i>[Signature]</i>
5	KU	KHARE POOJA RAJU	<i>[Signature]</i>
6	KU	INGE NISICHA SHILPA	<i>[Signature]</i>
7	KU	JANGLE VAISHANAVI ROSHAN	<i>[Signature]</i>
8	KU	KUNDARIPAVAR ARYA VIKAS	<i>[Signature]</i>
9		MAYKHAKE MAYHE PRASHANT	<i>[Signature]</i>
10	KU	MITESHKANT NARAJUM SUDHAKAR	<i>[Signature]</i>
11	KU	PAVANDEHRAJANUSHA ANAMI	<i>[Signature]</i>
12		PATE ROHIT SACHIN	<i>[Signature]</i>
13	KU	PAWAR SUMAN SHEMERDHE	<i>[Signature]</i>
14	KU	SHRIKESHANTISHA TABASSUM ALSI	<i>[Signature]</i>
15	KU	TILAK MAYHE RAJESH	<i>[Signature]</i>
16	KU	WADKAR ARYA ARUN	<i>[Signature]</i>
		Due	
		Present	13
		Absent	03

Sign of Invigilator

[Signature]

P-14-A 2

Shri Shivaji Education Society Amravati's Science College, Congress Nagar, Nagpur.
 ENVIRONMENTAL STUDIES EXAMINATION (2023 - 2024)
 Class :- B. Sc. - II (III & IV Sem)
 Subject :- ECSM Section :- A Batch :- M - 10

Sr. No	Roll	Students Full Name
1	Ku	AKRE KHUSHI KAILASH
2	Ku	BAGDE SHREYA TARACHAND
3	Ku	BARDE YASHIKA KUNDLIK
4		BHATTALWAR VARAD ATUL
5		CHANDEL JAY MANOJSINGH
6		CHAVAN PRATIK PREMDAS
7		DAWARE SARVESH SUDHIR
8	Ku	DOBLE VAISHNAVI GAJANAN
9	Ku	GHORMARE KRUTIKA ANKUSH
10		GHUGAL ABHISHAKTI HARIBHAU
11		HULKE VINAY MORESHWAR
12	Ku	KANHER JANHVI PANDHARI
13	Ku	KODANI PUNESHA DILIP
14	Ku	LENDE SANJANA KISHORJI
15	Ku	LUTE HIMANSHI RAMESH
16	Ku	MANKAR UJJWAL RAJESH
17	Ku	MOHATURE TANHVI CHANDRASHI KHAR
18	✓	UMREDKAR HARSHAL RAJESH
		Due
		Present
		Absent
		Sign. of Invigilator

Akreshi's
szagde
bande
bande
chandel
chavan
Sarvesh
V. G. Doble
Ghormare
Shakti
Hulke
J. P. Kanher
Punesh
Sanjana
Lute
Mankar
Mohature
Ujjwal
Harshal
 Absent 9322355846
 17
 01
P. N. D. S.

Shri Shivaji Education Society Amravati's Science College, Congress Nagar, Nagpur.
 ENVIRONMENTAL STUDIES EXAMINATION (2023 - 2024)
 Class :- B, Sc. - II (III & IV Sem)
 Subject :- SCSM Section :- B Batch :- M - 8

Sr. No	Roll	Students Full Name
1	✓	BANGRE ARPIT MANOJ
2		BALWE HRUSHIKESH SANJAY
3	Ku	BHAYDE PRATLEKSHA PRAVIN
4		BHENDARKAR KHUSHRANG JAIPRAKASH
5	Ku	BHUJADE RUTUJA RAJENDRA
6		BISEN SAGAR ARUN
7	Ku	BISWAS APARAJITA APURBAKUMAR
8		CHOUHAN SOMAY SATISH
9	Ku	DIWANGAN MAHENDRA GANESH
10	Ku	DUDHANKAR RUPALI RAJESH
11		FULMALI HITESH SANTOSH
12	Ku	GAMBHIYI YASH RAJU
13	Ku	GAWANDI AMRUTA VIJAY
14	Ku	GAWANDI NIKA GAJENDRA
15	Ku	GONDANE ISHA DINESH
16	Ku	GUPTA PRINCY ASHOK
17	Ku	GUPTA VAISHNAVI BHARAT
		Due 17
		Present 14
		Absent 03
		Sign. of Invigilator

Arpit

Pratik
Pratik

Pratik

Pratik

Admission Full Absent 8446547976

Pratik

Pratik

H. Fulmali

father Date Absent 7262877950

Pratik

Pratik

Pratik

Pratik

Pratik

Shri Shivaji Education Society Amravati's Science College, Congress Nagar, Nagpur.

ENVIRONMENTAL STUDIES EXAMINATION (2023-2024)

Class :- B. Sc. - II (III & IV Sem)

Subject :- SCSM Section :- B Batch :- M-9

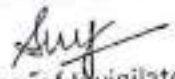
Sr. No	Roll	Students Full Name
1		INGLE AJINKYA MAHENDRA
2	Ku	KARANDI ASTHA GANGADHAR
3		KHODE YASH SANJAY
4	Ku	KUITE ANUSHKA VINOD
5	Ku	LICHADÉ AYUSHI KRISHNA
6	Ku	LOKHANDE AKANSHA ARVIND
7	Ku	MOHADIKAR AKSHITA PUSHPARAJ
8	Ku	NAGRIKAR ANUJA JAYANT
9	Ku	PANDEY KAMAL BRIJESH
10	Ku	PARATE PRANJAL JEEVAN
11	Ku	RAUT RAKSHA GAJANAN
12	Ku	SATFALE RAKSHA SANJAY
13	Ku	SINGALWAR FALGUNI ANIL
14	Ku	TOMAR ATHARVA JITENDRA
15	Ku	WAGDE ASHLESHA YUVRAJ
16	Ku	WAGHE SAKSHI SANDIP
17	Ku	YADAV SEJAL ASHOK
		Due 17
		Present 16
		Absent 01
		 Sign. of Invigilator

Ajinkya

Astha

Yash

Anushka

Ayushi

Akansha

Akshita

Anuja

Kamal

Pranjal

Raksha

Satfale

Falguni

Atharva

Ashlesha

Wagde

S. Yadav

call no: 9022261361

9022261361

Shri Shivaji Education Society Amravati's Science College, Congress Nagar, Nagpur,
 ENVIRONMENTAL STUDIES EXAMINATION (2023 - 2024)

Class :- B. Sc. - II (III & IV Sem)

Subject :- PCSM Section :- B Batch :- M-7

Sr. No		Students Full Name	Signature
1	Ku	MAMULKAR RAJVI PRASHANT	<u>Mamulkar</u>
2	Ku	MANKAR SAYALI DEVRAO	<u>Mankar</u>
3	Ku	MARWADE SANIKA BHASKAR	<u>Marwade</u>
4	Ku	MASKE MADHURA SUNIL	<u>Maske</u>
5	Ku	MOURYA HARSHIT PRAMOD	<u>Haat</u>
6	Ku	NASARE NIKHIL NARAYAN	<u>Nasare</u>
7	Ku	NASARE RAHUL RAJENDRA	<u>Nasare</u>
8	Ku	NIRANJANE VRUDDHI SAWAN	<u>Vruddhi</u>
9	Ku	PARDHI CHETANA MANISH	<u>Pardhi</u>
10	Ku	PATIL PRERNA HANAMANT	<u>Patil</u>
11	Ku	RADKE GUNJAN BHASHKAR	<u>Radke</u>
12	Ku	RAMTEKE SHASHANK NITIN	<u>Ramteke</u>
13	Ku	RATTHE ARYA VINOD	<u>Ratthe</u>
14	✓	SAHU DEVSHRI ASHOK	<u>Sahu</u>
15		SHIVHARE HARSHIT VIKRAM	<u>Shivhare</u>
16		SULAKHE MANDAR	<u>Sulakhe</u>
17	✓	CHANDRASHEKHAR SURYAWANSHI VAIBHAV DURYODHAN	<u>Chandrashekar</u>
18	Ku	TALNIKAR LAVANYA RAMAKANT	<u>Talnikar</u>
19	Ku	THAKARE PRACHI DILIP	<u>Thakare</u>
20	Ku	TIWARI PRIYA RAKESHKUMAR	<u>Tiwari</u>
21		TUBID YASHWARDHAN SIDHESHWAR	<u>Tubid</u>
		Due	21
		Present	19
		Absent	02
		Sign. of Invigilator	<u>Ashandhar</u>

Shri Shivaji Education Society Amravati's Science College, Congress Nagar, Nagpur
 ENVIRONMENTAL STUDIES EXAMINATION (2023 - 2024)
 Class :- B. Sc. - II (III & IV Sem)
 Subject :- PCSM Section :- B Batch :- M - 6

Sr. No	Roll	Students Full Name	Signature
1		BAWANKULE ANURAG AVIN	
2		BHOTMANGE YASH ASHOKRAO	
3	Ku	BHUTE VAISHNAVI CHANDRASHEKHAR Pappat dnyo hai	AB 7720861092
4	Ku	CHANODE SONU SHESHRAO	
5	Ku	CHAUDHARI SANIKA RAVINDRA	
6		DABHADE SAURABH DADARAO	
7	Ku	DAKHOLE MUGDHA RAJESH	
8		DANGORE SOHAM NITIN	
9	Ku	DHABRE VAISHNAVI DHIRAJ	
10	Ku	DHAWADE SHRAWANI DATTA	
11	✓	DOLAS SAHARSH SURESH	
12	Ku	GAIDHANE SMITA PURUSHOTTAM	
13		GAIKI VEDANT PRASHANT	
14	Ku	GANVIR SALONI RAJKUMAR	
15	✓	GIRDE CHITNA PRAKASH	
16	Ku	HEDAU SAYLI VIVEK	
17		JANGDE DEVANSH SANJAY	
18	Ku	KAMBLI DIVYA DINESH	
19	Ku	KAROKAR SHEJAL DIPAK	
20	Ku	KASHIKAR SANIKA RAHUL	
21	Ku	KHANDATE NEHA KISAN	
22	Ku	KHARWALE ASHWINI RATIRAM	
		Due	22
		Present	19
		Absent	03
		Sign. of Invigilator	 Ashwini Kharwale

Shri Shivaji Education Society Amravati's Science College, Congress Nagar, Nagpur,
 ENVIRONMENTAL STUDIES EXAMINATION (2023 - 2024)

Class :- B. Sc. - II (III & IV Sem)

Subject :- PEM Section :- A Batch :- M - 3,4

Sr. No	Roll	Students Full Name
1		BORKAR OM GAJANAN <i>Call nhi utthayu Absent</i> 9112927655
2		CHANIANA KIRANPREET KAUR SARVJEET SINGH <i>K Khanani</i>
3	Ku	DUBEY ISHA ROSHAN <i>Csh</i>
4		FULZELE KASHISH GAJENDRA <i>Fulzele</i>
5	Ku	GOWARDIPE KAJAL PURUSHOTTAM <i>Kp Gowardipe</i>
6		HEDAOD DHIRAJ RAJENDRA <i>Hr. Hedoo</i>
7		KAMBLE NAYAN ASHOK <i>Kambale</i>
8	Ku	KANGALE ACHAL RUSHI <i>Kangale</i>
9		KHOTELE MAYANK HEMANTKUMAR <i>MK</i>
10		MISHRA SHASHWAT RAMAKANT <i>Mishra</i>
11		MONDHE VISHAL VISHWANATH <i>Mondhe</i>
12		NAGPURKAR GAGAN MAROTI <i>Absent</i>
13		SINGH KASHISH NAGENDRA <i>Ksingh</i>
14	Ku	SINGH SHEETAL AZAD <i>Sheetal</i>
15	Ku	SONWANE BHAGYASHREE CHANDRAKUMAR <i>Bsonwane</i>
16	Ku	YADAV TAMANNA VIJAY <i>Yadav</i>
		Due 14
		Present 02
		Absent
		Sign. of Invigilator <i>S. S. S. S.</i>

Sri Shivaji Education Society Amravati's Science College, Congress Nagar, Nagpur.
 ENVIRONMENTAL STUDIES EXAMINATION (2023 - 2024)

(Class :- B, Sec :- III, III & IV Sem)

Subject :- CBM Section :- C Batch :- B-2

Sr. No.	Roll	Students Full Name
1	Ku	ALDAR NUPUR RAJENDRA
2		BADGE HRUSHIKESH KIRAN
3	Ku	BHARNE POONAM NIRANJAN
4	Ku	BRUTE JANVI SACHIN
5	Ku	CHANGOLE ANUSHKA DEVIDAS
6	Ku	DALAL DHANASHREE VIKAS
7	Ku	DEOTALI SHRUTIKA DILIP
8	Ku	DESHMUKH TANVI RAJESH
9	Ku	DHAKATE KRUTIKA MAHESH
10		GHADGE SHIDHANT RAMUJI
11	✓ Ku	HEDIYATULLAH SUHANA MD
12	Ku	JOGANISHA SURAJ
13		KUNGHARE SANCHIT SHESHRAO
14	Ku	KADU UNNATI UMESH
15	Ku	KAMBAR SURBHI NARISH
16	Ku	KALOT MUSKAN HUSEIN
17	Ku	MASHAM KHUSHBU DEVANAND
18		MAGARE TANMAY PRADIP
19	Ku	PARDEWAR SALONI DINESH
20	Ku	PAGAMI MEETALI RAJENDRA
21		PATIL ANSHUL RAVINDRA
22	Ku	PRASAD SONAM RAMDATHI
23	Ku	RALHANDIWAR UMARANI SANJAY
24	Ku	SINGH MUSKAN KUNDAN KUMAR
25	Ku	THAKUR SHRUSHTI DEEPAKSINGH
26	Ku	UPARKAR JIJE VILAS
27	Ku	WALDE DURGA RAJU
28	Ku	WANKHEDJI JUHI MANOJ
		Due
		Present
		Absent
		Sign. of Invigilator

V. J. Patil
 H. J. Patil
 B. K. Patil
 J. K. Patil
 A. K. Patil
 K. K. Patil
 P. K. Patil
 J. K. Patil
 B. K. Patil
 R. K. Patil
 S. K. Patil
 M. K. Patil
 N. K. Patil
 O. K. Patil
 P. K. Patil
 Q. K. Patil
 R. K. Patil
 S. K. Patil
 T. K. Patil
 U. K. Patil
 V. K. Patil
 W. K. Patil
 X. K. Patil
 Y. K. Patil
 Z. K. Patil
 24
 04
 A. B. Patil

Shri Shivaji Education Society Amravati's Science College, Congress Nagar, Nagpur,
ENVIRONMENTAL STUDIES EXAMINATION (2023 - 2024)
 Class :- B. Sc. - II (III & IV Sem)
 Subject :- PCM Section :- A Batch :- M - I









Sr. No		Students Full Name	Signature
1	Ku	ARVIWALA HUZEFA KHUZEMA	
2	Ku	BAGHEL SONAM SANTOSHKUMAR	
3	Ku	BAIG TASMIYA HAMID	
4		BARSAGADE KALASH SUDHAKAR	
5	Ku	BAWANKULE LAXMI DEVIDAS	
6	Ku	BHASMOTE ARADHANA RAJENDRA	
7	<input checked="" type="checkbox"/>	CHANNE TANISHKA PRAVEEN	
8	Ku	DATIR PRANJALI ANKALESH	
9	Ku	DESHMUKH JANHAVI VIRENDRA	
10		DHOK SOKSHAM NISHANT	
11	Ku	FULKUWAR PRIYA SANTOSH	
12	Ku	GAJBHIYE SWEJAL PRASHANT	
13	Ku	GONNADE MADHURIMA SHAILESH	
14	Ku	IRGURALA VIDYA CHANDRAIAH	
15	Ku	JIBHEKAR SAMRUDDHI KISHOR	
16	Ku	KALE AVANI PREMDAS	
17	Ku	KHADSE CHETANA MORESHWAR	
18	Ku	KUBADE TEJASWI MOTIRAM	
		Due	
		Present	16
		Absent	02
		Sign. of Invigilator	

Shri Shivaji Education Society Amravati's Science College, Congress Nagar, Nagpur.
ENVIRONMENTAL STUDIES EXAMINATION (2023 - 2024)
 Class :- B. Sc. - II (III & IV Sem)
 Subject :- PCM Section :- A Batch :- M-2

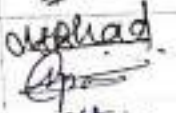

Sr No		Students Full Name	Signature
1		LOKHANDE KASHISH SUHAS	<i>Kashish</i>
2	Ku	LUTE SUHANI RAMESHWAR	<i>Suhani</i>
3	Ku	MENDWADE AISHWARYA PRAKASH	<i>Ayash</i>
4		NAMDEO ARYAN UMASHANKAR	<i>Aryan</i>
5	✓	PAIGAMI MANISH RAJENDRA	Absent 7028912438
6	Ku	PAL VAISHNAVI VINOD	<i>Vaishnavi</i>
7	Ku	SAHU APURVA TAPAN	<i>Asahy</i>
8	Ku	SAPATE PORNIMA PRABHU	Absent 9022256032
9	Ku	SONTAKKE RAJVEE SAROJ	<i>Rajvee</i>
10	Ku	THAKARE SUHANI SUKHADEO	<i>Suhani</i>
11	Ku	THAKUR KRITI AINKATRAO	<i>Kriti</i>
12	Ku	TOMAR TANU LXANDERKUMAR	<i>Tanujomar</i>
13	Ku	TONGE SUHANI ANAND	<i>Ayash</i>
14		VYAS HIMANSHU MUKESH	<i>Himanshu</i>
15	✓	WAHANE PREMANSHU ANIL	<i>Premanshu</i>
16	Ku	WAHANE TEJASVI PRAVIN	<i>Tejasvi</i>
17	Ku	WASNIK RUTIKA VINAYAK	<i>Rutika</i>
		Due	12
		Present	05
		Absent	
		Sign. of Invigilator	<i>Appanah</i>

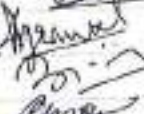
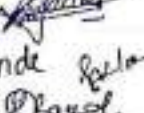
P-13 A-4

Shri Shivaji Education Society Amravati's
Science College, Congress Nagar, Nagpur
B.Sc. and BCA Part-II Sem IV
Environmental Studies
2023-2024

B.Sc Sem V	Batch	Batch No.	Room No.	Name of Invigilator	Signature
B.Sc Sem V	PCSM	M 6	B 12	Mrs. Shraddha Yeole	
		M 7		Shalaka Saygaokar	
	SCSM	M 8	Ku. A. A Choudhari		
		M 9	Ms. Prachi Khobragade		
	CBZ	B 3	B 13	Ms. Prajakta Feddewar	
		B 4		Ms. Payal Talekar	
	CMBT	B 5	B 9	Dr. Sapna Baghel Ms. Sanehari Sarkar	
		B 6		Ms. Nupur Deshmukh	
	PEM	M 3, 4	C 9	Mrs. Sarika Tekade	
	ECSM	M 10		Mrs. Pallivi Butle	
CZM	B1	B 7	Ku. Kanchan Jivanapurkar		
CBM	B2	B 6	Mrs. Mayuri Bhad		
CGM	G1	Ku. Shivani Patil			
CBG	G2	C 5	Dr. Shilpa Katre		
PCG	G3		Ms. Chanchal Jain		
PCM	M1	C 6	Ms. Pragati Bire nos R.R. Patil		
	M2		Ms Shruti Agrawal		
BCA			C 10	Ku. Anandi Banginge	
				Ku. Ritika Ganvir	
				Ku. Amruta Bais & V. Lokhande	
			Ku. Rasika Bagal		

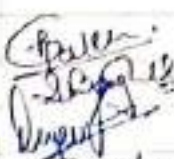
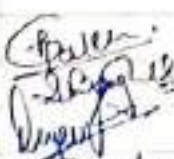
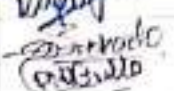
Shri Shivaji Education Society Amravati's
Science College, Congress Nagar, Nagpur
B.Se. and BCA Part-II Sem IV
Environmental Studies
2023-2024

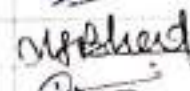
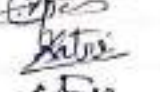
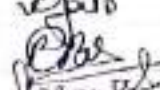
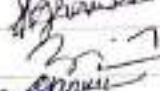
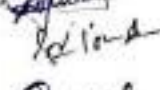
B.Se Sem IV	Batch	Batch No.	Room No.	Name of Invigilator	Signature
B.Se Sem IV	PCSM	M 6	B 12	Mrs. Shraddha Yeole	
		M 7		Shalaka Saygaokar	
	SCSM	M 8		Ku. A. A Choudhari	
		M 9		Ms. Prachi Khobragade	
	CBZ	B 3	B 13	Ms. Prajakta Feddewar	
		B 4		Ms. Payal Talekar	
	CMBT	B 5	B 9	Ms. Sanchari Sarker <small>Dr. Sapna Baghel</small>	
		B 6		Ms. Nupur Deshmukh	
	PEM	M 3, 4	C 9	Mrs. Sarika Tekade	
	ECSM	M 10		Mrs. Pallivi Butle	
	CZM	B1	B 7	Ku. Kanchan Jivanapurkar	
	CBM	B2	B 6	Mrs. Mayuri Bhad	
	CGM	G1		Ku. Shivani Patil	
	CBG	G2	C 5	Dr. Shilpa Katre	
PCG	G3	Ms. Chanchal Jain			
PCM	M1	C 6	Ms. Pragati Birre <small>Ms. P.P. Sidi</small>		
			M2		Ms. Shruti Agrawal
BCA			C 10	Ku. Anandi Banginge	
				Ku. Ritika Ganvir	
				Ku. Amruta Bais <small>Ms. V. Lakhande</small>	
			Ku. Rasika Bagal		

38	Ku	HEDAU CHETNA SUNIL	<u>Chetna</u>
39		HIRUDKAR MILASHANT KISANAJI	
40	Ku	HULKE PRACHI MAHESH	<u>Prachi</u>
41	Ku	JALUGAI TANUSHREE IJAM	<u>Tanushree</u>
42		KAMBLE DARSHAN SUDESH	
43		KAPSE ERNATH VIJAY	
44	Ku	KATRE PRANALI CHANDRAKANT	<u>Pranali</u>
45	Ku	KHANDARE NANDINI VIJAYRAO	<u>Nandini</u>
46	Ku	KHANDATE VANSHIKA ARUN	<u>Vanishika</u>
47		KHANDERKAR PIYUSH CHANDRAMANI	<u>Piyush</u>
48		KHAN MOIN ABDUL WAHID	
49		KHARADE YASH PRAVIN	<u>Yash</u>
50		KOKATE MANAS SHAILENDRA	<u>Manas</u>
51	Ku	KOLNEKAR TANUSHREE REVNATH	<u>Tanushree</u>
52		KSHIRSAGAR HARSH ASHISH	<u>Harsh</u>
53		KUMBE KRUNAL AJAY	<u>Krunal</u>
54	Ku	LATKAR AISHWARYA NAMDEV	<u>Aishwarya</u>
55		MAHARJUNE ALIKESH ARUN	<u>Alikesh</u>
56		MALGHATE TANMAY PREMGOPAL	<u>Tanmay</u>
57	Ku	MALGHATE TULSI UMARANT	<u>Tulsi</u>
58		MANE ADITYA KAILAS	<u>Aditya</u>
59		MASRAJI ANURAG GANESH	<u>Anurag</u>
60	Ku	MESHARAM RUCHIRA SHAIKAR	<u>Ruchika</u>
		MESHARAM VAIBHAVI	<u>Vaibhavi</u>
61	Ku	CHAVELASHREEBHAR	<u>Chavhavi</u>
62		MISHRA ANURAG HARISHKUMAR	
63	Ku	NAGPURE PRANALI PRABHAKAR	<u>Pranali</u>
64	Ku	NAKSHANE SAMIRSHA NARENDRA	<u>Samirsha</u>
65	Ku	PADWE YASHASHREE RAMESHRAD	<u>Yashashree</u>
66		PANDEY ANUPAM RAJESH	
67	Ku	PANDEY PRIYI DUEVORA	<u>Priy</u>
68	Ku	PARDHI KHUSHI UDELAL	<u>Khushi</u>
69	Ku	PATYI KOMAL KALASHI	<u>Komal</u>
70	Ku	PATLE TRUPTI ASHOK	<u>Trupti</u>
71	Ku	PATLE VAIBHAVI DHANPAL	<u>Vaibhavi</u>
72		PATHE NITESH NEERAJULAL	<u>Nitesh</u>
73		PANWAR AYUSH BABAN	<u>Ayush</u>
74	Ku	PISE RAJNI MANOIRAO	<u>Rajni</u>
75		RAHANGDALE GAURAV LAXMICHAND	
76	Ku	RANGE SNEHAL RAVINDRA	<u>Snehal</u>
77	Ku	KARATHE SHRUTI RAJESH	<u>Shruti</u>
78	Ku	RAUT RISHIJA ASHOK	<u>Rishi</u>
79		SARIARE SARVESH RAMESH	<u>Sarvesh</u>
80		SANAP VIKAS NAMDEO	<u>Vikas</u>

81	Ku	SHAHARE PUJAN SANJAY	<u>Pujan</u>
82	Ku	SHARNAGATE ARCHANA TEJRAM	<u>Archana</u>
83	Ku	SHENDE AKANKSHA AJAYKUMAR	
84		SONBARSE YASH NARESH	<u>Yash</u>
85	Ku	TAKALKHEDE HARSHALI ASHOK	
86	Ku	TAMBULKAR PUSHPAK ANIL	<u>Pushpak</u>
87		TAREKAR AAYUSH RAJENDRA	
88		TEMBHARE DEVASHISH SANTOSHKUMAR	<u>D.S. Tembhare</u>
89	Ku	THAKRE ISHWESHWARI RAJENDRA	<u>Is</u>
90	Ku	THAWARE NAMRATA PRAMOD	<u>AA D</u>
91		THOKAL ABHISHEK SANJAY	
92		THORAT OM PANKAJ	<u>Om</u>
93	Ku	TURKAR TANVI DINESH	<u>Tanvi</u>
94	Ku	UMARE KAJAL ASHOK	
95	Ku	VAIDYA NEHA VIJAY	<u>Ne ha</u>
96	Ku	WAGH SHREYA LAHU	
97		WANKHEDE TEJAS DNYANESHWAR	
98	Ku	WARATKAR NIKITA SATISH	<u>Nikita</u>
99		WASNIK ANURAG RAJESH	<u>Anurag</u>
100	Ku	WASNIK SNEHA SANDIP	
101	Ku	WELE SANJANA VINOD	
102		YADAV SHLOK CHANDAN	<u>Shlok</u>
103		YEKUDE ANSHU GUNWANT	
104	Ku	YEKUDE TEJASWINI PUNDLIK	<u>Tejaswini</u>
105	Ku	YENKAR LEENA MURLIDHAR	
106	Ku	ZADE ANUJA VILAS	<u>Anuja</u>

Environment Project Topic

Topic

- 1) Pollution, Control of Pollution & Prevention
- 2) Climate Change
- 3) Biodiversity
- 4) Recycling
- 5) Sustainability
- 6) Energy conservation
- 7) Environmental economics
- 8) Wildlife Conservation
- 9) Environmental ethics
- 10) Renewable energy
- 11) Marine Conservation
- 12) Water conservation
- 13) Solar Panel & Wind Turbines
- 14) Recycling
- 15) Human impact on forests
- 16) Water Purification

Project Submitted List

Sri Chhatrapati Education Society, Amravati - Science College, Campus - Nimal, Nagpur.
 ENVIRONMENTAL STUDIES EXAMINATION (2023 - 2024)
 Class :- B.Sc. - II (III & IV Sem.)
 Subject :- CRZ Section - C Batch :- B-1
Project Submission

Sr. No.	Roll No.	Students Full Name
1		KAWARI JAYDEEPTI
2		DAISWAL KASHISHMANGOL
3	Ka	DAISWAL SALONI SATISH
4	Ka	KALAMBE SHREYA GURUWANI
5	Ka	KASERAM LITA SANJAY
6	Ka	KADGAN LAKSHITA SANJAY
7	Ka	KADKARU LAKSHMI ROHIT
8	Ka	KADKARU SHRUTI
9	Ka	KADKARU SHRUTI
10	Ka	KADKARU ASHWINI RAVI
11	Ka	KADKARU SARITA VILAS
12	Ka	KADKARU SUSHIL BEHARAD
13	Ka	KADKARU SMITA ARVIND
14	Ka	KADKARU PRACHI DHARMENDRA
15	Ka	KADKARU MRUNMAYEE
16	Ka	KADKARU
17	Ka	KADKARU BHAGYSHREE VILAS
18	Ka	KADKARU MRUNAL RANJIT
19	Ka	KADKARU MRUNALI RAVESH
20	Ka	KADKARU AKANSHA VIDYUT
21	Ka	KADKARU DEEPIKA PAVAN
22	Ka	KADKARU SARITA SURESH
23	Ka	KADKARU DEVIYANI HANMANTR
24	Ka	KADKARU ANVITA ANRUDHA
25	Ka	KADKARU LAKSHMI
26	Ka	KADKARU

K.M. Jaiswal
Saloni
Shreya
ERta
Lakshita
Laxmi
Shruti
Ashwini
Sarita
Sushli
Smrita
Prachi
M.P. Sathawane
Bhagyashree
Shruti
Deviyani
Akshita
Anvita
Tanya Shree

Sri Shivaji Education Society Amravati's Science College, Congress Nagar, Nagpur,
 ENVIRONMENTAL STUDIES EXAMINATION (2023 - 2024)
 Class :- B.Sc. - II (III & IV Sem)
 Subject :- CBZ Section :- C Batch :- B - 3

Project Submitting

Sl. No	Roll	Students Full Name
1	Ku	ADIRKAR TULNA DILIP
2		AGHIHOTRI DEVESH MAHESH
3	Ku	ALAM AUYA MID AFTAB
4	Ku	ALONE KHUSHI PRADHIDAS
5	Ku	ARSHOLIKAR ISHIKA MANISH
6	Su	BACDE DIYA DEEPAK
7	Ku	BAGHEL UMAKANTI JAGMOHAN
8		BAISWARE ADITYA MAHESH
9	Ku	BHAGAT ANURADHA ARUN
10	Ku	BHANSNI SEVAL SUSHIL
11	Ku	BHORGADE SNEHA MANISH
12	Ku	BISEN GINAL SHANKAR
13	Ku	BORSE PRANALI ANIL
14	Ku	CHANDOKAR GARIMA
15	Ku	CHITAP PAYAL RAMAYO
16	Ku	DESHMUGH ROHINI VINOD
17	Ku	DHOLE MANJRI ANIL
18		DHOLE YASH SUNIL
19		DUTTA RAVEN SOMI
20	Ku	FALZLE SUHANI SAHADEO
21	Ku	GHAYWAT YASHASHREE SANJAY
22	Ku	GHORE MANUSHKA VINOD
23	Ku	GUPTA MOHINI
		MAHENDRAKUMAR

Tulna
 Divesh
 MID
 Khushi
 Ishika
 Diya
 Umakanti
 Anuradha
 Seval
 Manish
 Pranali
 Garima
 Payal
 Rohini
 Manjri
 Yash
 Raven
 Suhani
 Yashashree
 Manushka
 M.M. Gupta

Project Submission

Sr. No	Roll	Students Full Name	Signature
1		BAWANKUL ANURAG AVIN	<u>Anurag</u>
2		BHOTMANGI YASH ASHOKRAO	
3	Ku	BEHTE VAISHNAVI CHANDIKASHI KHAN	
4	Ku	CHANDOL SONU SHI SHRAD	<u>Sonu</u>
5	Ku	CHAUDHARI SANIKA RAVINIDRA	<u>Sanika</u>
6		DARHADE SMT. RAJESH DADARAO	
7	Ku	DARHOLE MUGDHA RAJESH	<u>Mugdha</u>
8		DANGORE SOHAM NILEEN	<u>Soham</u>
9	Ku	DHABRE VAISHNAVI DHIRAJ	
10	Ku	DHAWADE SHRAWANI DATTA	<u>Shrawani</u>
11		DOLAS SAHARSH SURESH	<u>Saharsh</u>
12	Ku	GADHANE SMITA REKESHKUTTARA	
13		GADGE DANI PRASHANTI	<u>Prashanti</u>
14	Ku	GANVIL SALONI RAJKUMAR	<u>Saloni</u>
15	Ku	GIRRE CHEENA PRANAV	<u>Pranav</u>
16	Ku	HEDAD SAYLI JAYESH	<u>Sayli</u>
17		JANGDE DEEPAK SANJAY	
18	Ku	KAMBLE DIVYA DINESH	<u>Divya</u>
19	Ku	KAROKAR SHEJAL DIPAK	
20	Ku	KASHIKAR SANIKA RAHUL	
21	Ku	KHANDATE NEHA KISAN	<u>Neha</u>
22	Ku	KHARWALE ASHWINI RATILAL	<u>Ashwini</u>

Shri Shivaji Education Society, Antravadi's Science College, Congress Nagar, Amravati.
 ENVIRONMENTAL STUDIES EXAMINATION (2023 - 2024)
 Class :- B. Sc. - II (III & IV Sem)
 Subject :- PCG Section :- D Batch :- G - J
Project Submission

Sr. No	Roll No	Signature
1	Ku ADHAU PURVA PRAMOD	Purva
2	Ku CHAUDHARI DURGESHVAR RAMPRASAD	Das
3	Ku DHORE SADIICHHA DILIP	Sadi
4	Ku GUPTA KSHITI ADITYASHEKHAR	Kshiti
5	Ku HAJARE PODIA RAJU	Podia
6	Ku INGLE NISHCHAL SHILPA	Nishchal
7	Ku JANGLE VAISHNAVI ROSHAN	VAISHNAVI
8	Ku KUNDARPAYAR ARYA VIKAS	Arya
9	Ku WASHKARE MAYUR PRASHANT	MAYUR
10	Ku MESHRAM MASUM SUHAKAR	Masum
11	Ku PALANDURKAR ANUSHKA ADAR	Anushka
12	Ku PATIL ROHIT SACHIN	Rohit
13	Ku PAVAR SUMAN SHEKHAR	Suman
14	Ku SHEKH MANSI SHA TABASSUM ALTAJ	Mansi
15	Ku TUPTAT MAYURI RAJESH	M. R. Tuptat
16	Ku WUKEY ARYA ARUN	Arya

Shri Shivaji Education Society Amravati's Science College, Congress Nagar, Nagpur.

ENVIRONMENTAL STUDIES EXAMINATION (2023 - 2024)

Class :- B. Sc. - II (III & IV Sem)

Subject :- CBG Section :- D Batch :- C - 2

Project Submission

Sr. No	Roll	Students Full Name
1	Ku	MOHAMMED SAHIL ANWAR MOHID SADIQUE MOTIWALA S
2	Ku	BANSOD ANJALI VISWAS Anjali
3	Ku	BEDADE MANISHA JANARDAN manish
4	Ku	BOPCHE PAYAL NANDKISHOR Payal
5	Ku	KADBLE SAYALI CHANDRAPAL Sayali
6	Ku	LONAIKAR JANHAVI PRAMOD
7		MANWATKAR AAHAN DEEPAK
8	Ku	NARNAWANE SAKSHI APIL Sakshi
9	Ku	NIMJE AINIKIA SUSHIL KUMARI Nimje
10	Ku	HAVITEKE HITALI PADMAKAR Hitali
11	Ku	TIANGARI YASHIKA SUSHIL Yashika
12	Ku	SALVE SAKSHI NITIN
13	Ku	UIKE VIDYA MAROTRAO
14	Ku	UIKEY GAYATRI TEJRAM Gayatri
15	Ku	WAHANE KOMAL DEVANAND Komal

Shri Shivaji Education Society Amravati's Science College, Congress Nagar, Nagpur.
ENVIRONMENTAL STUDIES EXAMINATION (2023 - 2024)

Class :- B. Sc. - II (III & IV Sem)

Subject :- CMHT Section :- C Batch :- II - 5

Project Submission

Sr. No	Roll	Students Full Name	
1	Ku	ANASANE VAIDEHI GANESH	
2	Ku	ANBOLE TRUPTI DNYANESHWAR	
3		ATILKAR PRANAY DNYANESHWAR	
4	Ku	BAGDE YASHIKA PRAMOD	Pramod - Yashika
5	Ku	BARDE VISHA PRAKASH	Visha
6	Ku	BHOYAR HEMAD AJAY	Ajay
7	Ku	BHUSHANWAR MRUNALI NARESH	Mrunali
8	Ku	BISEN KAJAL DEBILAL	Kajal
9	Ku	BOLE ANCHAL ANOOP	Anchal
10	Ku	BONDE SHRUTI VINOD	
11	Ku	BONDRE TITHI KUSUMA KAR	Tithi
12		BORKAR DUSHANT RUSHI	Dushant
13	Ku	BRAMHANKAR SMRUTI SAHJAY	Smruti
14		CHAVHAN AYUSH DILIP	Ayush
15	Ku	CHIKHALKAR HARSHADA WASUDEV	Harshada
16	Ku	CHOUDHARI BHARVI VIKAS	Bharvi
17	Ku	DALVI CHETNA KAILAS	Chetna
18	Ku	DHOBE RIYA SATISH	Riya
19	Ku	GAJBIHYE ARPITA KISHOR	Arpita
20	Ku	GHUGAL RUSHALI GHANSHYAM	Rushali
21	Ku	GUJWAR KHUSHBU PURANSINGH	Khushbu
22		HAKIM SHAFIN RAFIYODDIN	
23		HIVARKAR BAUNAK KRISHNA	Baunak
24	Ku	INGOLE NIKITA BANDU	Nikita
25	Ku	ISHWARIKAR KANBILA YOGRAJ	Kanbila
26	Ku	JAMBHULKAR KALSHIKA SUDESH	Kalshika
27	Ku	JIWANE GRECY CHANDU	Greacy
28		JOSHI ARYAN SHRIPAD	Aryan

- 29 KADAMDHAD MAYUR
YOGESHWAR
- 30 Ku KALAMKAR SHRAVANI MADHUKAR
- 31 Ku KALE GAURI ATUL
- 32 Ku RAMBE ARPIT AVINASH
- 33 Ku KAMBLE KOMAL SANJAY
- 34 Ku KAWDE KHUSHI RAJU
- 35 Ku KELAPURE SAI PRIYA
RAMCHANDRA
- 36 Ku KHOT SAMIKSHA GHANSHYAM
- 37 Ku KOTHAKARI AWANTI SANEBRAO
- 38 Ku KULTHE SNEHA PAWAN
- 39 ~~Janavi Samarth~~
- 41) Humera Afroz
- 42) Sign. Of Convener
Mayur Kadhadhad
- 43) Sakshi Vaideg
- 44) Janika Zaid
- 45) mitali Thakre
- 46) Housh waghri
- 47) Khushi Singh
- 48) Harshat Upadhyay

S.M. Kalamkar.

~~Arp~~

~~Arp~~

~~Samir~~
~~Samir K.~~

~~Arp~~

~~Arp~~

~~Arp~~

~~Arp~~

~~Arp~~

~~Arp~~

~~Arp~~

~~Arp~~

~~Arp~~

Shri Shivaji Education Society Amravati's Science College, Congress Nagar, Nagpur.

ENVIRONMENTAL STUDIES EXAMINATION (2023 - 2024)

Class :- B. Sc. - II (III & IV Sem)

Subject :- CMBT Section :- C Batch :- B - 6

Project Submission

Sr. No	Roll	Students Full Name
1	KR	KUTHE HEMAKSHI MAHESHKUMAR
2	KR	MADAN MOKSHITA HARISH
3	KR	MANKAR MAITREYEE KISHOR
4	KR	MARASKOLE NETRA PRADEEPKUMAR
5	KR	MATE SHREYA SUDHAKAR
6	KR	MESHARAM DIVYALI EKNATH
7	KR	MORE DHANASHREE DEEPAK
8	KR	NAIKWADE AASAWALI PRABHANJAN
9		PANDEY DURGESH GORUL
10	KR	PANDEY ISHIKA AMARNATH
11	KR	PANDEY VISHAKHA SURENDRA
12		PATHADE SARTHAK RAJENDRA
13	KR	PAWADE PRADNYA PURUSHOTTAM
14	KR	POUNIKAR SAKSHI ROSHAN
15		RAKSHAK YUGANT LAXMAN
16	KR	RAMTEKE ISHITA CHANDRASHEKHAR
17	KR	RAUT NEHA BABURAO
18	KR	RAUT SALONI GHISH
19	KR	RAUT SANIKA DILIP
20	KR	ROHANKAR NIYA MUKESH
21		Aishwarya zinkhade.

Mokshita
Maitreyee

Shreya

Dhanashree

Durgesh
Ishika

Vijay

Pradnya

Ishita

Neha

Saloni

Sarthak

Riya

Aishwarya

Shri Shivaji Education Society Amravati's Science College, Congress Nagar, Nagpur.
 ENVIRONMENTAL STUDIES EXAMINATION (2023 - 2024)
 Class :- B. Sc. - II (III & IV Sem)
 Subject :- CUM Section :- D Batch :- G - I
Project Submission

Sr. No	Roll No	Students Full Name
1	Ku	BAGHELE AARTI OMSHANKAR
2	Ku	BHONDGE KUMALI SATISH
3	Ku	BOMBARDE SHREYA VIJAY
4	Ku	CHOUDHARI NANDINI DINKAR
5	Ku	DHARMIE DEVASHREE BHURAO
6	Ku	DHOKRE SANJANA ANKUSH
7		DHUDSE ADITYA RITESH
8	Ku	GUDADHE VINA DILIP
9	Ku	KALE SUMATI SANJAY
10		KHARE JATIN SURESH
11	Ku	KOSEKAR KOMAL KISANA
12	Ku	MEHAR HIMANSHI VIJAY
13	Ku	NANDANWAR SALONI ARUN
14		NEMADE RAM ARUN
15	Ku	PATEWAR SHARVARI MANIKLAD
16	Ku	HAUT MOHINI MANOHAR
17		SAWARKAR SWAYAM KISHOR
18	Ku	LIKEY KRITIKA YOGESH
19		WAHALE PRESHIT RAJESH
20	Ku	WANKAR NANDINI LAXMAN
21	Ku	WANKEDE SNEHAL SANJAY

Shri Shivaji Education Society Amravati's Science College, Congress Nagar, Nagpur.
ENVIRONMENTAL STUDIES EXAMINATION (2023 - 2024)

Class :- B. Sc. - II (III & IV Sem)

Subject :- PCM Section :- A Batch :- M - I

Project Submission

Sr. No		Students Full Name	Signature
1	Ku	ARVIWALA HUZEL A KHUZEMA	
2	Ku	BAGHEL SONAM SANTOSHKUMAR	S. Baghel
3	Ku	BAIG TASMIYA HAMID	Tasmiya
4		BAISAGADI KALASH SUDHAKAR	
5	Ku	BAWANKULE LAXMI DEVIDAS	Laxmi
6	Ku	BHASMOTE ARCHANA RAJENDRA	A. Bhasmote
7	Ku	CHANNE TANISHKA PRAVITIN	
8	Ku	DATIR PRANJALI ANKALISH	
9	Ku	DESHMUKH JANHAVI VIRENDRA	Janhavi
10		DHOK SORSHAM NISHANT	S. N. Dhok
11	Ku	FULEKWAR PRIYA SANTOSH	
12	Ku	GAUBHIYE SWIJAL PRASHANT	S. Gaubhiye
13	Ku	GONNADE MADHURIMA SHAILSHI	
14	Ku	IRGURALA VIDYA CHANDRAIAH	Vidya
15	Ku	JIBHEKAR SAMRUDDHI KISHOR	Samruddhi
16	Ku	KALE AVANI PRIMDAS	Avani
17	Ku	KHADSE CHETANA MOHI SHYAM	Chetana
18	Ku	KUBADE TEJASWI MOTIRAM	T. Kubade

Shri Shivaji Education Society Amravati's Science College, Congress Nagar, Nagpur.

ENVIRONMENTAL STUDIES EXAMINATION (2023 - 2024)

Class :- B. Sc. - II (III & IV Sem)

Subject :- PCM Section :- A Batch :- M - 2

Project Submission

Sr. No	Students Full Name	Signature
1	LOKHANDE KASHISH SUHAS	<u>Lokhande</u>
2	Ku LITE SUHANI RAMESHWAR	<u>Suhani Lite</u>
3	Ku MENDWADE AISHWARYA PRAKASH	<u>A. Mendwade</u>
4	NAMDIO ARYAN UMASHANKAR	<u>Aryan</u>
5	PAIGAMI MANISH RAJENDRA	<u>Manish</u>
✓	Ku PAL VAISHNAVI VINOD	<u>V. Pal</u>
7	Ku SAHU APURVA TAPAN	<u>A.T. Sahu</u>
8	Ku SAPATE PORNIMA PRABHU	<u>Pornima</u>
9	Ku SONTAKKE RAJVE SAROJ	<u>Saraj</u>
10	Ku THAKAR SUHANI SUKHADLO	<u>Suhani</u>
11	Ku THAKUR PRIYANKA TRAO	<u>Priyanka</u>
12	Ku TOMAR TANU EXANDIRKUMAR	<u>Tanu</u>
✓	Ku TONGE SUHANI ANAND	<u>Suhani</u>
14	VYAS HIMANSHU MUKESH	<u>Himanshu Vyas</u>
15	WAHANE PRIMANSHU ANIL	<u>Primanshu</u>
16	Ku WAHANE TEJASVI PRAVIN	<u>Tejasvi</u>
✓	Ku WASNIK RUTIKA VINAYAK	<u>Rutika</u>

Shri Mivaji Education Society Antravati's Science College, Congress Nagar, Nagpur.

ENVIRONMENTAL STUDIES EXAMINATION (2023 - 2024)

Class :- B. Sc. - III, III & IV Sem)

Subject :- PCSI Section :- B Batch :- A-7

Project Submission

Sr. No	Students Full Name	Signature
1	Ku. WAMLIKANI RAJVI PRASHANT	Rajvi
2	Ku. WANKAR SAYALI DEVKAD	Sayali
3	Ku. MARWADE SANKA BHASKAR	Sanka
4	Ku. MASKE MADHURA SUNIL	
5	Ku. MOURYA HARSHIT PRAMOD	Harshit
6	Lu. NAGARE NIKHIL NARAYAN	Nikhil
7	Ku. NAGARE RAHUL RAJENDRA	Rahul
8	Ku. NIRANJANI VRUDDHI SAWAN	Vruddhi
9	Ku. PAREKH CH. TASA MANISH	Chetana
10	Ku. PATIL PREENA HANUMANT	Preer
11	Ku. PANDIT GUNJANI BHASKAR	
12	PAMATHE SHASHANK TATIN	Shashank
13	Ku. PATIL ARYA VINOD	Arya
14	Ku. SANE DEVSHRI ASHOK	Devshree
15	SHIRHARE HARSHIT VIKRAM	
16	SULAKHE MADHANI	Madhavi
	CHANDRASEKHAR	
17	SURWANWANTI VAMHAY DURYODHAR	Vishnu
18	Ku. TALIKAR LAVANYA RAJASGANT	Lavanya
19	Ku. THAKAR PRACHI DRIP	Prachi
20	Ku. THAKAR PRIYA RAJESHKUMAR	Priya
21	TUNG YASHWANTKUMAR	Jashwanth
	SOHESHKAR	
22	Sayali Kulkarni	Sayali
23	Sign. Of Convener	
24	Seloni Ganis	Seloni

Shri Shivaji Education Society Amravati's Science College, Congress Nagar, Nagpur.

ENVIRONMENTAL STUDIES EXAMINATION (2023 - 2024)

Class :- B. Sc. - II (III & IV Sem)

Subject :- SCSSM Section :- B Batch :- M - 8

Project Submission

Sr. No	Roll	Students Full Name
1		BANGRE ARPI MANDI
2		DAIWE ARUSHIKESH SANJAY
3	Ku	BHAYDE PRAHITIKSHA PRAVIN
4		BHENDARRAR KHUSHRANG JAI PRAKASH
5	Ku	BHUSADE RUTUJA RAJENDRA
6		BISEN SAGAR ARUN
7	Ku	BISWAS APARAJITA APURBAKUMAR
8		CHOUHAN SOMAY SATISH
9	Ku	DEWANGAN MAHENDRA GANESH
10	Ku	DUDHANKAR RUPAL RAJESH
11		FULMALI HITESH SANTOSH
12	Ku	GAMBHIYI YASH RAJU
13	Ku	GAWANDE AMRITA VIJAY
14	Ku	GAWANDE NEHA GAJENDRA
15	Ku	GONDANE ISHA DINESH
16	Ku	GUPTA BHINCY ASHOK
17	Ku	GUPTA VANSHNAVI BHARAT

Banerk Arpi

Shri Shivaji Education Society Amravati's Science College, Congress Nagar, Nagpur.
 ENVIRONMENTAL STUDIES EXAMINATION (2023-24)

Class :- B. Sc. - II (III & IV Sem)

Subject :- SCSM Section :- B Batch :- A1 - 9

Project Submission

Sr. No	Roll	Students Full Name
1		INGLE AJINKYA MAHENDRA
2	KU	KARANDE ASTHA GANGADHAR
3		KHODE YASH SANJAY
4	KU	KUTE ANUSHA VINOD
5	KU	LICHADE AYUSHI KRISHNA
6	KU	LOKHANDE AKANSHA ABHINAV
7	KU	MOTHADIKAR AKSHITA PUSHPARAJ
8	KU	NAGRİKAR ANUJA JAYANTI
9	KU	PANDEY KAMAL BRIJESH
10	KU	PARATE PRANJAL JE EVAN
11	KU	RAUT RAKSHA GAJANAN
12	KU	SATTALI RAKSHA SANJAY
13	KU	SINGALWAR FALGUNI ANIL
14	KU	TOMAR ATHARVA JITENDRA
15	KU	WAGDE ASHLESHA YUVRAJ
16	KU	WAGHE SAKSHI SANDIP
17	KU	YADAV SITAL ASHOK

At

Pratik

Yashuade

ayushi

Akhande

As

Akhande

Anuja

PP

Bindu K

As

Pransalwal

Ashlesha

Sneha Lakhe

Shri Shriyaj Education Society Amravati's Science College, Congress Nagar, Nagpur.
 ENVIRONMENTAL STUDIES EXAMINATION (2023 - 2024)
 Class - B. Sc. - II (III & IV Sem)
 Subject - ECSSM Section - A Batch - 31 - 10

Project Submission

Sl. No	Roll	Students Full Name
1	Ku	ARRE KHUSHI KAILASH
2	Ku	BACDE SHREYA JABACHAND
3	Ku	BARDI YASHIKA KUNDLIK
4		BHATTALYAR VARAD ATUL
5		CHANDIL JAY NANDISINGH
6		CHAVAN PRATIK PREMDAS
7		GAJWARE SARVESH SUDHIR
8	Ku	GOBLE YASHNAVI GAJANAN
9	Ku	GHORMANE RITVIKA ARKUSH
10		GHUGA ABHISAKTI HARIBHAI
11		HILKE VINAY MORESHWAR
12	Ku	KADHER JASHVI PANDHARI
13	Ku	KOCHANE PUNESHA DILIP
14	Ku	LENGE SANIYAMA KISHORI
15	Ku	LITTE HIMANSHI HAMESH
16	Ku	MANWAR DEEPAK RAJESH
17	Ku	MOHATPURE TANVI CHANDRASHI KHAN
18		OMREDDI HARISHA RAJESH

Sri Shivaji Education Society Amravati's Science College, Congress Nagar, Nagpur
 ENVIRONMENTAL STUDIES EXAMINATION (2023 - 2024)
 Class :- B.Sc. - II (III & IV Sem.)
 Subject :- CZM Section :- C Batch :- B-1

Project Submission

Sr. No	Roll No	Students Full Name
1	Ku	ARYAGARI RENUKA SUDHAKAR
2	Ku	DANTI SHRADHA GUDDE
3	Ku	BEHRE KHUSHI RAJU
4	Ku	BHAIKARE CHETANA DINESH
5	Ku	BHANTE SHRIYA SURENDRAKUMAR
6	Ku	CHOUHARY VAISHNAVI CHANDRUKAMET
7	Ku	GUPVA ANUSHKA ANDI
8	Ku	GOSWAMI DIVYA VIKAS
9	Ku	GOSWAMI LAXMI KISHOR
10	Ku	GUPTA SHREYA NAVINDRA
11	Ku	KALE MRUNALI CHANDRAJEET
12	Ku	KOLHE HARSHINI ARVIND
13	Ku	LONJE HARSHADA RAJESH
14	Ku	NICHOD SAMRUDDHI SATISH
15	Ku	MUDE DIVYA SIDDHAKAR
16	Ku	PURHARSHI REYA SUSHILSINGH
17	Ku	PATIL MRUTULA PRANIL
18	Ku	PHADANURADHA RAJASHRI
19	Ku	PUSADKAR ANNADA VIKAS
20	Ku	RAMTEGI ROHANSI SHESHIN
21	Ku	RAJOD SHALINI ANIL
22	Ku	RAUT RIYA TEJODHAR
23	Ku	SANGHVI KUNAL RAJ
24	Ku	SHIRANE FALGUNI SANDIP
25	Ku	THAKAR KADAMBARI SANJAY
26	Ku	THAKRE VISHAL VINAY
27	Ku	UPASE VANDHI MANOHAR
28	Ku	WADHAWAN TANUJA GORJI
		Sign. Of Convener

Renuka
Shradha
Khushi
C.D. Bhaisakh
Shriya
Vaishnavi
Anushka
Divya
Laxmi
Shreya
Mrunali
Harshini
Harshada
Samruddhi
Reya
Mrutula
Annada
Rohansi
Shalini
Ris
Janvi
Falguni
Kadambari
Vishal
Vandhi
Tanuja

Sl. No.	Roll No.	Name of Student	Signature
1	60	ADITYA RAJESH RAJESH	
2	61	ADARSH HIRSHIR SHIRSHIR	
3	62	ADARSH HIRSHIR SHIRSHIR	
4	63	ADARSH HIRSHIR SHIRSHIR	
5	64	ADARSH HIRSHIR SHIRSHIR	
6	65	ADARSH HIRSHIR SHIRSHIR	
7	66	ADARSH HIRSHIR SHIRSHIR	
8	67	ADARSH HIRSHIR SHIRSHIR	
9	68	ADARSH HIRSHIR SHIRSHIR	
10	69	ADARSH HIRSHIR SHIRSHIR	
11	70	ADARSH HIRSHIR SHIRSHIR	
12	71	ADARSH HIRSHIR SHIRSHIR	
13	72	ADARSH HIRSHIR SHIRSHIR	
14	73	ADARSH HIRSHIR SHIRSHIR	
15	74	ADARSH HIRSHIR SHIRSHIR	
16	75	ADARSH HIRSHIR SHIRSHIR	
17	76	ADARSH HIRSHIR SHIRSHIR	
18	77	ADARSH HIRSHIR SHIRSHIR	
19	78	ADARSH HIRSHIR SHIRSHIR	
20	79	ADARSH HIRSHIR SHIRSHIR	
21	80	ADARSH HIRSHIR SHIRSHIR	
22	81	ADARSH HIRSHIR SHIRSHIR	
23	82	ADARSH HIRSHIR SHIRSHIR	
24	83	ADARSH HIRSHIR SHIRSHIR	
25	84	ADARSH HIRSHIR SHIRSHIR	
26	85	ADARSH HIRSHIR SHIRSHIR	
27	86	ADARSH HIRSHIR SHIRSHIR	
28	87	ADARSH HIRSHIR SHIRSHIR	
29	88	ADARSH HIRSHIR SHIRSHIR	
30	89	ADARSH HIRSHIR SHIRSHIR	
31	90	ADARSH HIRSHIR SHIRSHIR	
32	91	ADARSH HIRSHIR SHIRSHIR	
33	92	ADARSH HIRSHIR SHIRSHIR	
34	93	ADARSH HIRSHIR SHIRSHIR	
35	94	ADARSH HIRSHIR SHIRSHIR	
36	95	ADARSH HIRSHIR SHIRSHIR	
37	96	ADARSH HIRSHIR SHIRSHIR	
38	97	ADARSH HIRSHIR SHIRSHIR	
39	98	ADARSH HIRSHIR SHIRSHIR	
40	99	ADARSH HIRSHIR SHIRSHIR	
41	100	ADARSH HIRSHIR SHIRSHIR	

Dr. P.B. Zamarkar

Project

ENVIRONMENTAL STUDIES



NAME : SANIKA RAHUL KASHIKAR

CLASS : BSc II SEMESTER IV

GROUP : PCSM

BATCH : M6 ROLL NO : 26

DATE OF SUBMISSION : 28th march 2024

TOPIC : Human Population And The
Environment.

Human Population

And

The Environment

The relation between human population growth and the environment is complex and multifaceted. As the human population increases, it places greater pressure on natural resources, ecosystem and the environment as a whole. Here is a brief overview:

- 1) Resource Depletion: A growing population requires more resources such as food, water, energy and raw materials. This leads to overexploitation of natural resources, including deforestation, depletion of fisheries, and exhaustion of freshwater source.
- 2) Habitat Destruction: Human population growth often results in habitat destruction through activities such as urbanization, agriculture, and infrastructure development. This leads to the loss of biodiversity, fragmentation of ecosystem, and displacement of wildlife.
- 3) Pollution: Increasing population leads to higher level of pollution, including air pollution from industrial activities and transportation, water pollution from agriculture and urban runoff, and soil contamination from improper waste disposal. Pollution negatively impact human health, biodiversity, and ecosystem.
- 4) Climate Change: Human activities associated with population growth such as burning fossil fuels and deforestation contribute to climate change. Climate change poses significant challenges to biodiversity and ecosystem stability.

- 5) Overexploitation: Increasing human population leads to higher demands for resources such as food, water, timber and fuel. Overexploitation of these resources can lead to the decline or extinction of species, disrupting ecosystems and reducing biodiversity.
- 6) Invasive species: Human activities such as international trade and travel, facilitate the spread of invasive species to new areas. These non-native species can outcompete native species, disrupt ecosystems and contribute to declines in biodiversity.
- 7) Fragmentation: Human development often fragments habitats, isolating populations of species and reducing gene flow. Fragmentation can lead to decreased genetic diversity within populations, making them more vulnerable to environmental changes and disease.
- 8) Loss of Ecosystem: Biodiversity loss reduces the ability of ecosystems to provide essential services such as pollination, water purification, and carbon sequestration. This can have cascading effects on human well-being, including impacts on agriculture, water quality, and climate regulation.

Overall, the rapid growth of the human population exerts immense pressure on biodiversity and ecosystem stability, posing significant challenges for conservation efforts and the sustainable management of natural resources. Addressing these challenges requires co-ordinated efforts to reduce consumption, protect habitats, mitigate pollution, and promote sustainable development practices.

Carrying capacity refers to the maximum population size that an environment can sustainably support over the long term, given the resources available. When it comes to human populations, the concept of carrying capacity is complex due to our ability to modify our environment, develop new technologies and adapt behaviours.

Here are some key points regarding carrying capacity and human population:

- 1) Environmental Resources: The carrying capacity of the earth for humans depends on factors such as available food, water, energy and space. These resources are finite and can become depleted if human population exceed sustainable levels.
- 2) Technological Advances: Human ingenuity and technological advancements have allowed us to temporarily exceed historical carrying capacities by increasing agricultural productivity, developing new energy sources, and improving resources management. However, these advances may have ecological and social consequences such as environmental degradation and inequality.
- 3) Ecological Footprint: The ecological footprint measures the amount of resources consumed and waste generated by a population compared to the earth's capacity to regenerate those resources and absorb the waste. When the ecological footprint exceeds the Earth's biocapacity, it indicates that the population is exceeding the planet's carrying capacity.

4) Population Growth: Human population growth can outpace the Earth's capacity to support it sustainably, leading to overconsumption, resource depletion, and environmental degradation. Sustainable population management involves addressing factors such as birth rates, consumption patterns, and resource distribution.

5) Limit to Growth: Some researchers argue that there are limits to growth imposed by environmental constraints, and exceeding these limits could lead to ecological collapse. Proponents of this view advocate for policies that aim to stabilize or reduce human populations to ensure long-term sustainability.

In Summary, the concept of carrying capacity is crucial for understanding the relationship between human populations and the environment. While technological innovations have temporarily expanded the Earth's carrying capacity for humans, sustainable population management and resource conservation are essential for ensuring a healthy and prosperous future for both people and the planet.

Current Population Trends

In recent years, global population trends have been characterized by several key patterns:

- 1) Continued Growth: While the rate of population growth has slowed compared to previous decades, the global population continues to increase steadily. This growth is primarily driven by high fertility rates in developing regions, particularly in Africa and parts of Asia.
- 2) Urbanization: A significant trend is the rapid urbanization of populations. More people are moving from rural areas to cities in search of better economic opportunities and improved living standards. This shift has implications for resource consumption, infrastructure development, and environmental sustainability.
- 3) Ageing Population: In many developed countries, populations are aging as birth rates decline and life expectancy increases. This demographic shift poses challenges related to healthcare, pension systems, and workforce productivity.
- 4) Regional Variations: Population growth rates vary widely across regions. While some areas experience rapid population growth, others are grappling with stagnant or declining populations.

Challenges and Obstacles.

Addressing the challenges and obstacles associated with the impact of human population growth on biodiversity and ecosystem stability is essential for implementing effective conservation and sustainable development strategies. Here are some of the key challenges and obstacles.

1) Political and Economic priorities: In many cases, short term political and economic priorities may take precedence over long term environmental considerations. Governments and business may prioritize economic growth and development over conservation efforts, leading to policies and practices that degrade ecosystems and threaten biodiversity.

2) Lack of Awareness and Education: A significant obstacle is the lack of awareness and understanding among the general public, policymakers, and stakeholders about the importance of biodiversity and ecosystem stability. Without adequate education and outreach efforts, it can be challenging to mobilize support for conservation initiatives and sustainable development practices.

3) Conflict Interests and Stakeholder Engagement: Conservation efforts often involve navigating complex social, cultural, and economic factors, as well as conflicting interests among stakeholders. Engaging diverse stakeholders, including local communities, indigenous peoples, governments, NGOs, and business, in decision-making processes can be challenging but is crucial for achieving sustainable outcomes.

4) Resource Constraints: Limited financial resources and capacity can hinder conservation efforts, particularly in developing countries where resources may be scarce. Insufficient funding for conservation programs, research, monitoring, and enforcement can impede progress in addressing biodiversity loss and ecosystem degradation.

5) Fragmented Governance and Coordination: Biodiversity and ecosystems often transcend political boundaries, requiring coordinated efforts across multiple sectors and jurisdictions. However, governance structures may be fragmented, with overlapping mandates and conflicting interests, making it difficult to implement cohesive conservation strategies and policies.

Conclusion

In conclusion, the relationship between human population and the environment is complex and multifaceted. As global population trends continue to evolve, it is imperative to recognize the interconnectedness between population growth, resource consumption, and environmental sustainability.

The evidence presented highlights the significant impacts of population growth on the environment, including deforestation, climate change, habitat loss, resource depletion, and pollution. These environmental challenges not only threaten ecosystems and biodiversity but also pose risks to human health, livelihoods, and future generations well-being.

Addressing these challenges requires a comprehensive approach that integrates population policies, environmental conservation efforts, technological innovations, and international cooperation. Strategies for sustainable development must prioritize equitable access to resources, promote renewable energy and efficient resource use, and support resilient ecosystems.

Moreover, it is essential to recognize the role of human behaviour, societal norms, and cultural practices in shaping population dynamics and environmental impacts. Education, empowerment, and awareness-raising efforts are critical for fostering sustainable lifestyles and promoting responsible stewardship of natural resources.

In navigating the complex interplay between human populations and the environment, collaboration among governments, civil society, academia, and the private sector is essential. By working together, we can develop holistic solutions that balance the needs of present and future generations while safeguarding the planet's ecological integrity.

Ultimately, addressing the challenges posed by population growth and environmental degradation requires a collective commitment to sustainable development, social equity, and environmental stewardship. Only through concerted action and shared responsibility can we build a more resilient and prosperous future for all.

SHRI SHIVAJI SCIENCE COLLEGE, NAGPUR



NAME : SAYALI KAMBLE

CLASS : BSC 2ND YEAR

BATCH : G-2

GROUP : CBG

SUBJECT : ENVIRONMENTAL SCIENCE

TOPIC : HUMAN POPULATION AND ENVIRONMENT

SUBMITTED BY: BSC 2nd YEAR

REPORT PREPARED BY SAYALI KAMBLE

P. B. Zamarkar

**SUBMITTED TO Dr P. B. Zamarkar
[Environmental Sciences]**

ACKNOWLEDGEMENT

I Would like to express my special thanks and gratitude to my professor - Dr P. B. Zamarkar for giving me a golden opportunity to know more about the topic of "human population and environment".

Your useful advice & suggestions were really helpful to me during completion.

In this aspect I express my special thanks to you for such a great learning experience.



NAME: SAYALI KAMBLE

Subject – Environmental Sciences

HUMAN POPULATION AND THE ENVIRONMENT

Population growth:

Droughts, outbreak of diseases lead to human deaths. 14th century A.D experienced large scale mortality due to plague – about 50% of people in Asia and Europe died due to the disease.

Science and technological advancement have increased the expectancy of human. People started living with good sanitation food and medical facilities increase in population exponentially. In agriculture based families children are said to be assets who help the parents in fields. Therefore, in developing countries the population increase is at a rate of 3.4% per year.

Causes of rapid population growth

- The rapid population growth is due to decrease in death rate and increase in birth rate.
- Availability of antibiotics, immunization, increased food production, clean water and air decreases the famine-related deaths.
- In agricultural based countries, children are required to help parents in the field that is why population increases in the developing countries.

Population

It is defined as a group of individuals of the same species living in the same area in a given time.

Population density

It is expressed as a no. of individuals of the population per unit area or per unit volume

Parameters affecting population size

1. Birth rate or Natality : It is the no. of birth per 1000 people in a population in a given year
2. Death rate: It is the no. Of deaths per 1000 people in a population in a given year
3. Immigration: It denotes the arrival of individual from neighboring population
4. Emigration: It denotes the dispersal of individuals from the original population to new areas.

Characteristics of population growth

- Exponential growth
- Doubling time
- Infant mortality rate
- Total fertility rate
- Replacement level
- Male/female ratio
- Demographic transition.

Variation of population based on age structure

Pre-productive population (0-14 years)

Reproductive population (15 – 44 years)

Post reproductive population (above 45 years)

1. **Pyramid shaped** – India, Bangladesh, and Ethiopia. [Large no of young people enter into reproductive age group, hence Population growth increases].
2. **Bell shaped** – France, USA, and UK. [pre-productive age group population & reproductive age group population are almost equal, hence population growth is stable].

3. **Urn shaped** - Germany, Italy, and Japan [pre-productive population is less than reproductive age groups hence population growth decreases].

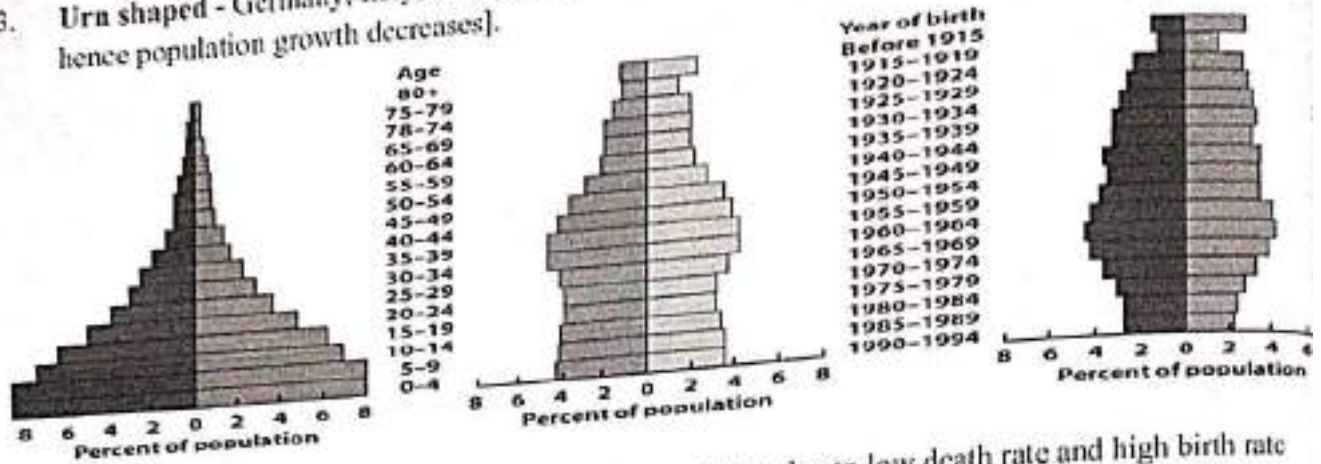

Population Explosion → The enormous increase in population due to low death rate and high birth rate

Doubling Time → The number of years needed for a population to double in size.

Causes of population explosion:

- Modern medical facilities reduces death rate & increases birth rate,
- Increase of life expectancy,
- Illiteracy.

Effects of population explosion (PE)

- Poverty - infant mortality is the tragic indicator of poverty
- PE leads to Environmental degradation,
- PE causes over - exploitation of natural resources,
- Renewable resources like forests are under threat,
- Increase in population increases disease, communal war
- Leads to development of slums
- Lack of basic amenities like water, education , health etc

Population characteristics and variation among nations:

1. **Exponential growth:** 1,3,5..... If a quantity varies by a fixed % 10^1 , 10^2 etc.

2. **Doubling Time $T_d = 70/r$** 2%

3. **Total Fertility Rate (TFR)** is 1.9 developing countries. 4.7 developed countries and 6.1 in 1950

4. **Infant mortality:** % of infants died out of those born in a year last 50 years.

5. **Replacement level:** Under low life expectancy and high infant mortality 2.7 in developing countries at developed countries.

6. **Life expectancy:** The average no. of years a new born baby is expected to live. The life expectancy global males and females has risen from 40 to 55.5 years. In India 22.6 and 23.3 in 1900 & 60.3 and 60 2000. In Japan and Sweden 77-77.4 & 82-84 years

Family welfare programme:

- Allows couples to describe their family size and also time spacing of their off spring
- Provide importance, knowledge and benefits of their small family to people
- Education in held and family welfare system Sex education awareness

WHO estimated 50% of worlds married couples adopted family planning measures, 300 million couples not assessed to family planning

FAMILY PLANNING PROGRAMME

Objectives

1. Reduce infant mortality rate.
2. Achieve 100% of birth, death, marriage, pregnancy registration
3. Encourage late marriages, late child-bearing.
4. Improve women's health, education, employment.
5. Prevent & Control of communal diseases.
6. Promote small family norms
7. Making free & compulsory education upto 14 yrs & Constraint spread of AIDS

Fertility control methods:

Traditional method → taboos and folk medicine

Modern method Permanent method (Sterilization done by minor surgery)

- a) Tubectomy = female sterilization done by tying the tubes carrying ovum to uterus.
- b) Vasectomy = male sterilization, done by tying the tubes carrying the

Temporary method

- a) Condoms = used by males to prevent sperms
- b) Copper Ts = small objects placed by doctor in the uterus
- c) Oral contraceptive pills, drugs

Environment and human health:

Environment is defined as man along with his surroundings, which consists of biotic, abiotic and sociological components. Therefore, when we cause danger to these components, which surrounds us, they in turn affect our health.

The environmental dangers created by man are many: Population explosion, unregulated urbanization, creating water, air and landscape pollution, deforestation, desertification, use of pesticides in agriculture etc. Every one of these has implications for the health of the individual as well as society as a whole. None can be ignored because the scale of potential calamity is increasing day by day.

Health hazards may be arising from: water contamination or pollution, air pollution, use of pesticides enters through food chain, radiation effect of nuclear water, diseases caused from improper disposal of solid wastes and also due to noise pollution.

HUMAN RIGHTS

Human rights are the fundamental rights, which are possessed by all human beings irrespective of their caste, nationality, sex and language.

IN 1948 Universal Declaration of Human Rights UNKHR was established by UN.

- Human right to freedom [express views, forming union, building houses, choose any profession]
- Human right to property [right to earn property]
- Human right to freedom of religion [freedom to choose religion to his wishes]
- Human right to culture and education [right to conserve culture, language, establishing educational institutions]
- Human right to constitutional remedies [can go to court, if fundamental rights are denied]
- Human right to equality [all citizens are equal before law without discrimination of religion, sex, caste, place]
- Human right against exploitation [children should not be employed as labours]
- Human right to food and environment [right to get sufficient food, safe, water, healthy environment]
- Human right to good health [right to have very good physical and mental health].

VALUE EDUCATION

It is nothing but learning about the particular thing through knowledge. We can identify our values ourselves with the help of knowledge and experience.

Types

1. Formal education-
Self related learning process, all will read, write, get jobs, tackle any problem with formal education.
2. Value education –
Analyze our behavior, provide proper direction to youth, know right & wrong.
3. Value-based environment education-
knowledge about principles of ecology, biodiversity, care for natural resources, know to safe and clean environment.

Objectives

- To improve the integral growth of human beings.
- To create attitudes and improvement towards sustainable lifestyle.
- To increase awareness about our national history our cultural heritage, constitutional rights, national integration, community development and environment.
- To create and develop awareness about the values and their significance and role.
- To know about various living and non- living organisms and their interaction with environment.

Value Education:

Education is one of the most important tools in bringing about socioeconomic and cultural progress in a country. The objective of education should not be merely coaching the students to get through the exams, get good results and get some good job. Education does not simply mean

Value based environmental education:

Environmental education is something that every person should be well versed with. The principles of ecology and fundamentals of environment help to create a sense of earth citizenship and a sense of care for earth and its resources - a sense of commitment towards the management of the resources in a sustainable way so that our children and grand children too have a safe and clean planet.

Following the Supreme Court directives 1998 environmental education has been included in the curriculum right from the school stage to university level. The objective of it is to make everyone environment

erate. Let us see how environmental education can be made value based one.

Preparation of text books materials on environmental education – to built a positive attitude towards environmental factors.

Social values like love, tolerance, compassion can be woven into environment. Education. This will help to nurture all forms of life and biodiversity.

Cultural and religious values: Our culture and religions teach us not to exploit nature – but to perform such functions which project and sacred nature. Therefore these value scan be added up with environment. Education.

Environment Education should stress on earth centric views rather than human centric view such that it include the ethical values.

Global values: Stress on the concept human is part of nature and all natural processes are inter linked and they are in harmony. If this harmony is disturbed it may lead to imbalance in ecology and catastrophic results.

Spiritual values: highlights on self contentment, discipline, reduction of wants etc. This will reduce our consumerist approach. If the mentioned values are incorporated in environment education, the goal of sustainable development and environment conservation can be easily attained. Value based environment Education can bring about a total transformation of our mind set, our attitudes and life style to protect nature.

Methods of Imparting value Education:

- Telling
- Modeling - presenting ideas to learner's as model
- Role Playing - Acting the role of another person
- Problem Solving - Asking the learners about their decision during dilemma
- Studying biographies of great man - use of great man good deeds & worthy thoughts

WOMANS WELFARE

Need of Women Welfare

- Women suffer gender discrimination
- Devaluation at home, matrimony, workplace, public & power
- Dowry death, rape, domestic violence, mental torture to women
- Human rights are violated, decision making are neglected

Objectives

- To provide education
- To impart vocational training
- To generate awareness
- To improve employment opportunities
- To restore dignity, equality and respect.
- To aware problems of population

Objectives of National Commission For Women

- To examine constitutional & legal rights for women To review existing legislations
- To sensitize the enforcement & administrative machinery to women's causes.

Various Organizations towards Women Welfare:

- The National Network for Women & Mining (NNWM) → fighting for gender audit of

- India's mining companies
- United Nations Decade for Women → inclusion of women welfare related issues on international agenda.
- International Convention on the Elimination of All Forms of Discrimination Against Women (CEDAW) → Protection & Promotion of women's upliftment
- Non-Government Organizations (NGO's) → Empower, educate village women & making them independent
- Ministry for Women and Child Development → work for upliftment of women by family planning, health, education & awareness

CHILD WELFARE:

Reason for child Labors

- | | |
|---------------|---------------------------------------|
| Poverty | → work in unhealthy conditions |
| Want of Money | → parents need money for their family |

Various Organizations towards Child Welfare:

1. **UN Conventions on Rights of Child or International Law** → promote & protect children in society

Rights of the Child:

- | | |
|----------------------------|--|
| The right to survival | → emphasizes on good health, nutrition, standard of living |
| The right to participation | → freedom of thought to the child |
| The right to development | → ensures education, care, support, social security & recreation |
| The right to protection | → freedom from exploitation, inhuman treatment & neglect |

2. **World summit on children** → well being of the children is targeted

3. **Ministry of Human Resource Development (MHRD)** → concentrate on child's health, education & nutrition

4. **Center for Science & Environment (CSE)** - keeping environment clean for healthy life of children

HIV/AIDS

AIDS is the abbreviated form for Acquired Immuno Deficiency Syndrome caused by a virus called (Human Immune deficiency Virus). Immune deficiency means that the disease is characterized by a weakness of immune system

Origin of HIV/AIDS

1. Through African Monkey or Chimpanzees to human.
2. Through Vaccine Programme
 - a. Polio, small pox vaccine prepared from monkey's kidney-Africa.
 - b. spread through Hepatitis-B viral vaccine-Los Angeles and New York.
 - c. through small pox vaccine programme of Africa

Scenario in India: India ranks 2nd with 5.1 million HIV affected people. The % is lower than Thailand, Myanmar & South Africa

Factors influencing modes of Transmission of HIV

1. Unprotected sex with infected person.
2. Using needles or syringes from HIV positive person.
3. During pregnancy, breast feeding HIV transmits from mother to infant babies.
4. Blood transfusion during accident and pregnancy.
5. Biologically the male to female transmission is 2 to 4 time more efficient than female to male transmission.
6. Women's cervical tissue is more vulnerable to HIV than men.
7. Transmission of HIV to new born babies happen easily

Factors not influencing transmission of HIV

1. Tears, food, air, cough, handshake and normal kissing.
2. Mosquito flies and insect bites.
3. Sharing of utensils, clothes, toilets and bathroom.

Functions of HIV in human body

- White blood cells (WBC) are responsible for the formation of antibodies called T-helper cells-
- T- helper cells are the key infection fighters in the immune system.
- Once HIV cells are enter into the boy they destroy the T-cells & cause many infection diseases.

Major symptoms

- Persistent cough for more than one month.
- General skin disease. Viral infection.
- Fungus infection in mouth and throat.
- Frequent fever, headache and fatigue

Other symptoms

- Fever for more than one month
- Diarrhea for more than one month.
- Cough & TB for more than one month.
- Fall of hairs.
- 10% of body weight loss within short period.

Control and Preventive measures

1. **Education.** → health education, avoid sharing razors, needles and syringe
2. **Prevention of Blood borne HIV transmission.** → screening of blood for HIV before transmission & following strict sterilization in hospitals
3. **Primary health care** → AIDS awareness programme, participation of voluntary health agencies].
4. **Counseling services** → Counseling through phone or through telephone].
5. **Drug treatment** → Early medical care, taking nutritious diet, maintaining stress free mind].

Effects

- Death
- Loss of labor & level of production decreases
- Inability to work due to lack of energy & frequent fever & sweating
- More water is needed for maintaining hygiene in AIDS affected locality.

Screening test:

- ELISA-Enzyme Linked Immuno Sorbent Assay
- Western blot

- DNA test
- Immuno fluorescent antibody assay

DENGUE FEVER

Dengue infection is caused by Arbovirus

- Dengue virus (DENV) infects 50 million (WHO) to 100 million (NIH) people annually.
- Forty per cent of the world's population, predominately in the tropics and sub-tropics, is at risk for contracting dengue virus.
- DENV infection can cause dengue fever, dengue haemorrhagic fever, dengue shock syndrome, and d

Dengue
Mosquito transmitted Viral Infection

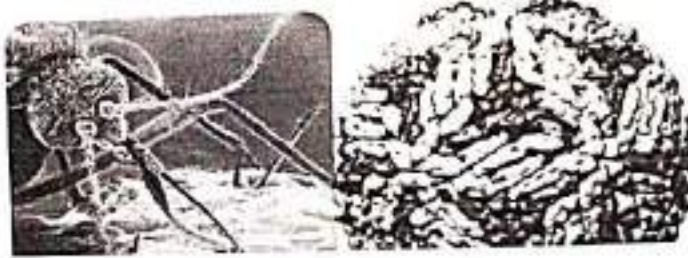

What causes Dengue?

- Dengue (DF) and dengue haemorrhagic fever (DHF) are caused by one of four closely related, but antigenically distinct, virus serotypes (DEN-1, DEN-2, DEN-3, and DEN-4), of the genus Flavivirus.
- Infection with one of these serotypes provides immunity to only that serotype for life.

How Mosquitos spread the infection

- The disease starts during the rainy season, when vector Mosquito *Aedes aegypti* is abundant
- The *Aedes* breeds in the tropical or semitropical climates in water holding receptacles or in plants close to human dwellings
- A female *Aedes* acquires the infection feeding upon a viremic human.
- After a period of 8 – 14 days mosquitoes are infective and remain infective for life. (1- 3) months.

Clinical Manifestations

- Any or few of the following events can occur.
- Fever,
- Severe head ache
- Muscle and joint pains
- Nausea, vomiting,
- Eye pain

How Dengue Infection starts and manifests

- Incubation period 4 – 7 days (3 – 14 days)
- Fever may start with, Malaise, chills, head ache
- Soon leads to severe back ache, joint pains, muscular pain, pain in the eye ball.
- Temperature may persist for 3 -5 days.
- On some occasions once again raises in about 5 – 8 days (Saddle back fever)
- Myalgia may be severe with deep bone pain

On majority of the occasions a self limited condition,
Subside on its own
Death is a rare event.

reatment

No Anti-viral therapy available
Symptomatic management in Majority of cases
Dengue Hemorrhagic fever to be treated with suitable fluid replacement
No Vaccine available, difficult in view of four serotypes.

ontrol of Dengue

- Control of Mosquito breeding places.
- Anti mosquito measures
- Use of Insecticides.
- Screened windows and doors can reduce exposure to vectors.

NE FLU

HAT IS SWINE FLU?

H1N1 flu is also known as swine flu. It's called swine flu because in the past, the people who caught it had direct contact with pigs. That changed several years ago, when a new virus emerged that spread among people who hadn't been near pigs.

In 2009, H1N1 was spreading fast around the world, so the World Health Organization called it a pandemic. Since then, people have continued to get sick from swine flu, but not as many.

ow Do You Catch It?

The same way as the seasonal flu. When people who have it cough or sneeze, they spray tiny drops of the virus into the air. If you come in contact with these drops, touch a surface (like a doorknob or sink) where the drops landed, or touch something an infected person has recently touched, you can catch H1N1 swine flu. People who have it can spread it one day before they have any symptoms and as many as 7 days after they get sick. Kids can be contagious for as long as 10 days.

vine Flu Symptoms

ese, too, are pretty much the same as seasonal flu. They can include:

- Cough
- Fever
- Sore throat
- Stuffy or runny nose
- Body aches
- Headache
- Chills
- Fatigue

ce the regular flu, swine flu can lead to more serious problems including pneumonia, a lung infection, and other breathing problems. And it can make an illness like diabetes or asthma worse.

ow Is It Treated?

me of the same antiviral drugs that are used to treat seasonal flu also work against H1N1 swine flu. Oseltamivir

(Tamiflu), peramivir (Rapivab), and zanamivir (Relenza) seem to work best, although some kinds of swine don't respond to oseltamivir. These drugs can help you get well faster. They can also make you feel better.

Besides a flu shot, there are other things you can do to stay healthy:

- Wash your hands throughout the day with soap and water. Sing the "Happy Birthday" song twice to sure you've washed long enough. Or use an alcohol-based hand sanitizer.
- Don't touch your eyes, nose, or mouth.
- Avoid people who are sick.

Role of Information Technology in Environment And Human Health:

Information technology means collection, processing storage & dissemination of information.

1. REMOTE SENSING [RS]

- Gathering information about an object without coming in contact with it is called remote sensing.
- Any force like acoustic, gravity, magnetic, electromagnetic etc. could be used for remote sensing.

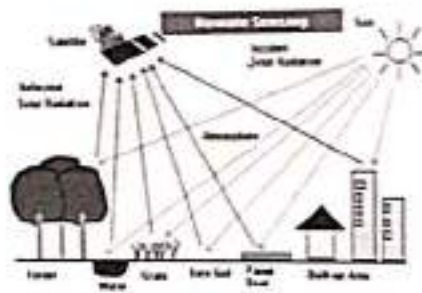

Applications

In agriculture → RS provide information about land, water management, use of seeds, fertilizer input etc

Forestry → Information on type, density & extent of forest cover, wood volume, forest fire, pest etc.

Land cover → Gives spatial information on land, RS data is converted to map

Water resources → surface water body mapping, ground water targeting, flood monitoring, water quality monitoring, run-off modeling, irrigation water management

2. DATA BASE (DB) - Collection of inter related data on various subjects.

Applications

- **Ministry of environment and forest** → compile data on biotic communities, diseases like HIV, malaria, flu etc
- **National Management Information System (NMIS)** → DB on R&D projects, research scientists etc.
- **Environmental Information System (ENVIS)** → DB on pollution control area, clean technology, biodiversity, remote sensing, environmental management, desertification etc

3. GEOGRAPHICAL INFORMATION SYSTEM (GIS)

It is a technique of superimposing various thematic maps using digital data on a large number of inter-related aspects.

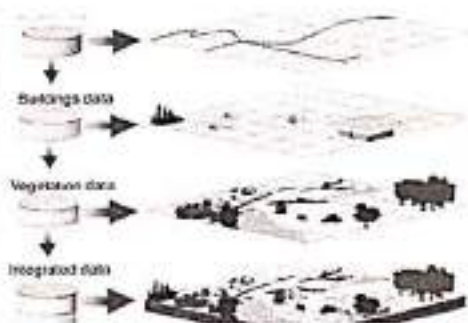

Application

- Thematic maps are super imposed using software's.
- Interpretation of polluted zones, degraded lands
- To check unplanned growth and related environmental problems.

SATELLITE DATA

- Helps in providing reliable information and data about forest cover
- Provide information about forecasting weather, smog, ozone depletion
- Reserves of oil, minerals can be discovered.

WORLD WIDE WEB → It provides more and latest data.

Important on line learning center

www.mmhc.com/environmentalscience

Multimedia digital content manager (DCM) in the form of CD-ROM

Applications

- These online learning center provides the current and relevant information on, principles, problems, quarries, application of EVS
- It has digital files of photos, power points lecture presentations, animations, web exercises and quiz.
- They are useful to both students and teachers of environmental studies

USE OF INFORMATION TECHNOLOGY IN HUMAN HEALTH

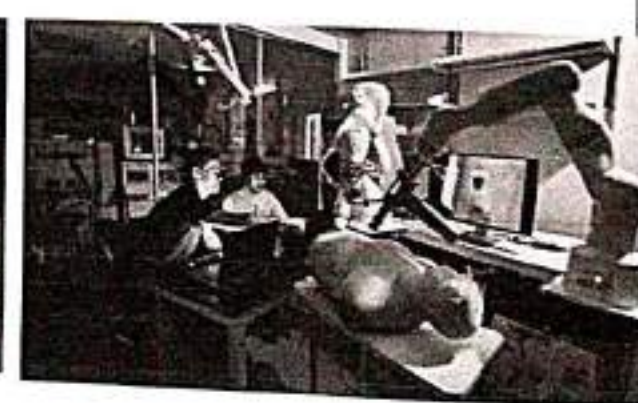

In Health

- WHO describes Health as a state of complete physical, mental and social well-being and not merely the absence of disease or infirmity.
- Innovations leading to converging of IT & Life Sciences creating new Work/Internships

- HIT (Health Information Technology) provides the umbrella framework to describe the comprehensive management of health information across computerized systems.
- Helps in exchange between consumers, providers, government, quality entities and insurers.

Databases

- Data regarding birth, death rates, immunization programs can be maintained more accurately than before health centers due to computers.
- Information and statistics about diseases like malaria, fluorosis, AIDS, etc.
- DNA databases and genetic information about population, medical records, fingerprints, etc can be stored and accessed.

Bioinformatics

- Inter-disciplinary field that develops methods and software tools for understanding biological data.
- Combines computer science, statistics, mathematics and engineering to study and process biological data.
- Major applications in sequence analysis, Databases, literature, structural bioinformatics, gene and protein expression analysis and algorithms, statistical methods to assess relationships

Telemedicine

- Use of telecommunication and information technologies in order to provide clinical care at a distance.
- Helps eliminate distance barriers. • Saves lives in critical care and emergency situations.
- Benefit remote regions with specialists living far away.
- Also eliminates the possibility of transmission in case of infectious diseases.

Biomechanics

- Robots that emulate or simulate living biological organisms or are inspired by them chemically or mechanically.
- Nanotechnology use is also being studied. • Nano-bots are programmed to act as delivery systems within organism (like blood).
- In biomimicry, robots have to be programmed to make the mechanism simpler and more effective.
- Research on humanoid robots is also becoming increasingly popular.

Controlling diseases

- Isolation is one of the major step in controlling highly infectious diseases.
- In the ongoing Ebola virus containment, spreading awareness was the first step taken.
- This reduces panic and provides information about prevention and if infected, treatment options.
- Several airports in many countries, screened passengers for high temperature and other symptoms via thermal sensors and computers without any manual labor need. This was possible due to applying IT services in medical fields.

Application of IT in health services

1. The data regarding birth and death rates, immunization and sanitation programme are maintained more accurately using IT packages
2. It helps the doctor to monitor the health of the people effectively
3. The information regarding the out break of epidemic diseases can be conveyed easily
4. On-line help of expert doctors can be consulted to provide better treatment and services to the patient
5. With a control system the hospital can run effectively
6. Drugs and its replacement can be administered efficiently

Shri Shivaji Education Society Amravati's
Science College,
Congress Nagar, Nagpur

Notice

Geological Tour Excursion Parseoni, Ramtek

All the students of B.Sc. Geology are hereby informed that a Geological field tour has been arranged in Parseoni, Ramtek on 6th March 2024.

Students should deposit Rs. 400/- and a consent letter (compulsory) on or before 05/03/2024. They should collect blank consent letters from department staff/attendants and get them signed by themselves and their parents. Students should note that a geological tour is a part of the syllabus and marks are also part of internal marks, hence it is compulsory for all students.

Note: Please bring a lunch box and water bottle.

Handwritten signature
Date 05/03/24

Handwritten signature of Dr A A Halder

Dr A A Halder
Coordinator, IQAC
Science College,
Congress Nagar, Nagpur.

Handwritten signature of Prof. M. P. Dhore

Prof. M. P. Dhore
Principal
Science College,
Congress Nagar, Nagpur



Action Taken Report

All three years of Geology students, and faculty members were present in the field. This excursion aimed to give knowledge about field aspects and how they are useful for the Geology peoples were explained by the geoscientists.

During the excursion, many field-related questions were asked by the students to scientists and answers were given by the respective people The excursion was successfully organized in the Parseoni and Ramtek area.

**Shri Shivaji Education Society Amravati's
SCIENCE COLLEGE, CONGRESS NAGAR, NAGPUR**

Session 2023 – 2024

Department of Geology

Organised “Geological Field Excursion to Parseoni & Ramtek Area ”

In association with

“Geological Survey of India Field Training Centre, Nagpur”

Under the Guidance of

Mr. Rashtrapal Chavhan (Director, GSIFTC, Nagpur)

Dr. Chatrapal Ramteke (Geoscientist, GSIFTC, Nagpur)

Date: 6th March 2024

Time: 7:30 – 8:00 PM

Department of Geology, SSES's Science College, Nagpur in association with **Geological Survey of India Field Training Centre, Nagpur**” on 6th February 2024 at 7:30 AM. Under the Guidance of Mr. Rashtrapal Chavhan (Director, GSIFTC, Nagpur) and Dr. Chatrapal Ramteke (Geoscientist from GSIFTC, Nagpur). All three years of Geology students, and faculty members were present in the field. This excursion aimed to give knowledge about field aspects and how they are useful for the Geology peoples were explained by the geoscientists. During the excursion, many field-related questions were asked by the students to scientists and answers were given by the respective people The excursion was successfully organized in the Parseoni and Ramtek area.



Students Leaving for the excursion from the college.



Mr. Rashtrapal Chavhan (Director, GSI Field Training Centre Nagpur) interacting with students in a field



Mr. Rashtrapal Chavhan (Director, GSI Field Training Centre, Nagpur) explaining about the toposheets.



Dr. Chatrapal Ramteke (Geoscientist, GSI Field Training Centre, Nagpur) explaining about the usage of Brunton Compass.



Mr. Rashtrapal Chavhan (Director, GSI Field Training Centre, Nagpur) while explaining the measurement of dip and strike.



Mr. Rashtrapal Chavhan (Director, GSI Field Training Centre, Nagpur) while explaining the measurement of dip and strike.



Students Collect the rock sample from the field.



Group Photo from the field.



Faculty members with the Geoscientist in the field.



Students having fun at the end of the field area.

1st year geology group.

Page No. _____
Date _____

	Name	Group	Age	Gender	Signature
1	Kavish Mankar	CGM (G1)	18	Female	[Signature]
2	Ananya Gulabke	PCG (G3)	18	Female	[Signature]
3	Bhumiika Thaware	CGM (G1)	19	Female	[Signature]
4	Pradyumna Rout	CGM (G1)	19	Female	[Signature]
5	Ukhuti Bankar	CGM (G1)	17	Female	[Signature]
6	Riddhi Rajput	CGM (G1)	19	Female	R. Rajput
7	Ashwani Abhinavastav	CGM (G1)	18	Male	[Signature]
8	Tanushree Yelne	CGM (G1)	18	Female	[Signature]
9	Abhaya Anupam	CGM (G1)	18	Female	A. Anupam
10	Akshati Kale	CBG (G2)	18	Female	[Signature]
11	Manasi Deshpande	CBG (G2)	19	Female	[Signature]
12	Ashwini Kathane	CBG (G2)	19	Female	[Signature]
13	Ayesha Jabeen	PCG (G3)	18	Female	[Signature]
14	Yugansh Kanoye	PCG (G3)	18	Male	[Signature]
15	Rohit Kumar Pat	CBG (G2)	20	Male	[Signature]
16	Kanudini Pawane	CBG (G2)	18	Female	[Signature]
17	Ashubh Dhangre	PCG (G3)	18	Female	[Signature]
18	Shivani Wkey	CBG (G2)	18	Female	[Signature]
19	Dalvi Delote	CBG (G2)	18	Female	[Signature]
20	Natasha Bidarkar	CBG (G2)	17	Female	[Signature]
21	Pratik Ramteke	PCG (G3)	23	Male	[Signature]
22	Dipak Baghel	CBG (G2)	18	Male	[Signature]
23	Sahil ^{Kapse}	CBG (G2)	18	Male	[Signature]
24	Aarja Nartam	CBG (G2)	18	Female	[Signature]

Geology short Tour 2024 "Ramtek"
Bsc. 2nd sem IV - [6th OF March]

Cash - 8400/-
Online - 2400/-
Page:
Date:

Name	Group	M/F	Sign.
1) Nidhal Ingle	PCG (G3)	F	
2) Durgeshwari choudhari	PCG (G3)	F	
3) Adhan. Manwatkar	CBG (G2)	M	
4) Arya Wikey	PCG (G3)	F	
5) Hitali Ramteke	CBG	F	
6) Pooja Hajare	PCG	F	
7) Sharvari Patil		F	
8) Nandini choudhari		F	
9) Kavitha Wikey	CGM	F	
10) Himanshi Mehar	CGM	F	
11) Kunal Bhondge	CGM	F	
12) Sumati Kale	CGM	F	
13) Gayatri Wikey	CBG	F	
14) Vidya Wikey	CBG	F	
15) Saloni Nandanwar	CGM	F	
16) Arya Kundarpawan	PCG	F	
17) Shreyal Bornbarde	CGM	F	
18) Sahil Motiwala	CBG	M	
19) Swayam Sawarkar	CGM	M	
20) Jatin Khare	-11-	M	
21) Aditya Dhudhde	-11-	M	
22) Ram Nemade	-11-	M	
23) Prerhit Wahale	-11-	M	
24) Aarti Baghele	-11-	F	
25) Sakshi Namaware	CBG	F	
26) Kshiti Gupta	PCG	M	
27) Purva Adhau	PCG	F	
28) Sayali Kambhe	CBG	F	
29) Anjali Bansod	CBG	F	

Camlin

Short Tour Names (3rd year)

1)	Sakshi Dubey	(G ₁)	Female	9325434949	Sakshi
2)	Saniya Borkar	(G ₁)	Female	7820965916	Saniya
3)	Rugved Joshi	(G ₁)	Male	9307496561	Rugved
4)	Harshal Mehar	(G ₁)	Male	7756074880	Harshal
5)	Priyanshu Athi	(G ₁)	Male	8475859678	Priyanshu
6)	Prachi sodikarane	(G ₂)	Female	9923619810	Prachi
7)	Sanchit Joshi	(G ₃)	Male	9519382461	Sanchit
9)	Pujal Tulshiram Nistane		Female	8788375730	Pujal
10)	Devesh Patle		Male	7559207725	Devesh
11)	Gaurav Pasharamkar		Male	9359004257	Gaurav
12)	Gauri Panchbudhe		Female	93120445704	Gauri
13)	Shradha Masram		Female	9561649445	Shradha
14)	Durgeshwari Tripathi		Female	8408911853	Durgeshwari
15)	Aditya vadibhasme		Male	9075001875	Aditya
16)	Palguni Kumbhare		Female	738707078352	Palguni

Feedback Analysis:

After successful completion of the program feedback from all the present students was collected. Analysis of feedback were done and after feedback analysis following observation noted remarkably.

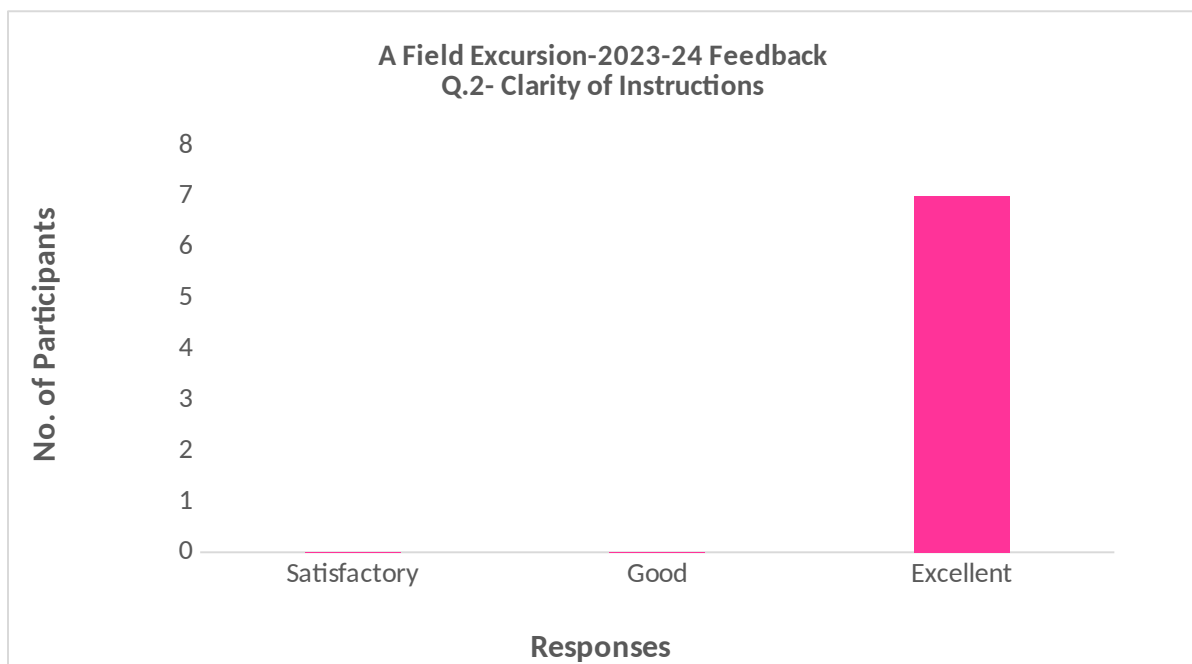
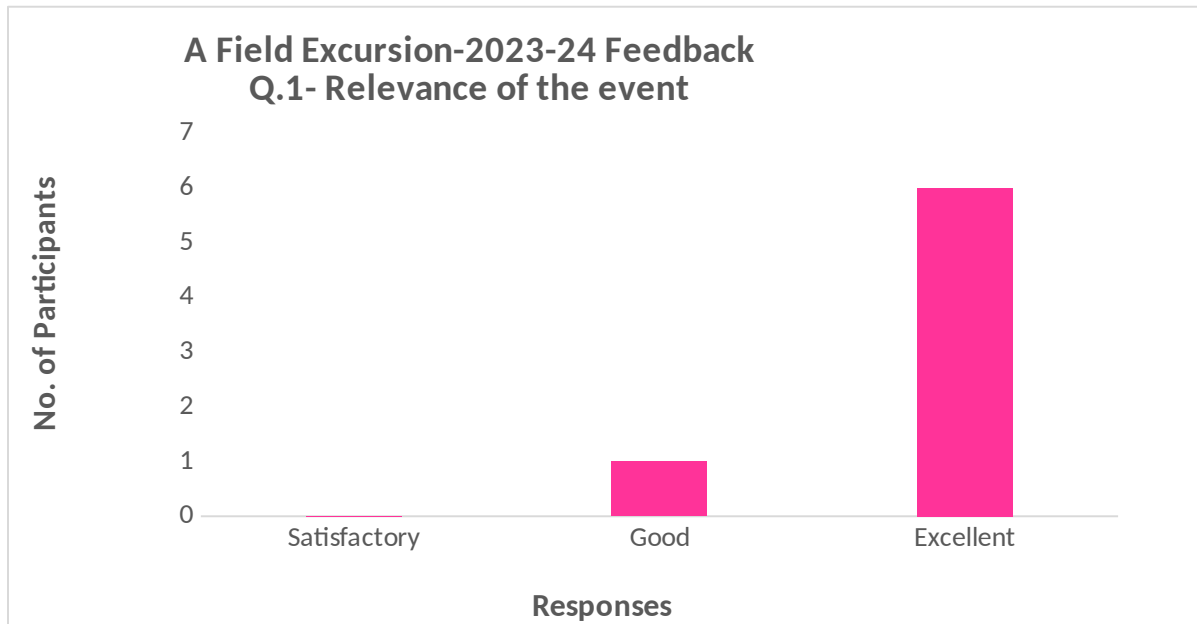

A Field Excursion-2023-24 Feedback Q.3- Engagement of Instructor





A Field Excursion-2023-24 Feedback Q4- Interaction and Participation

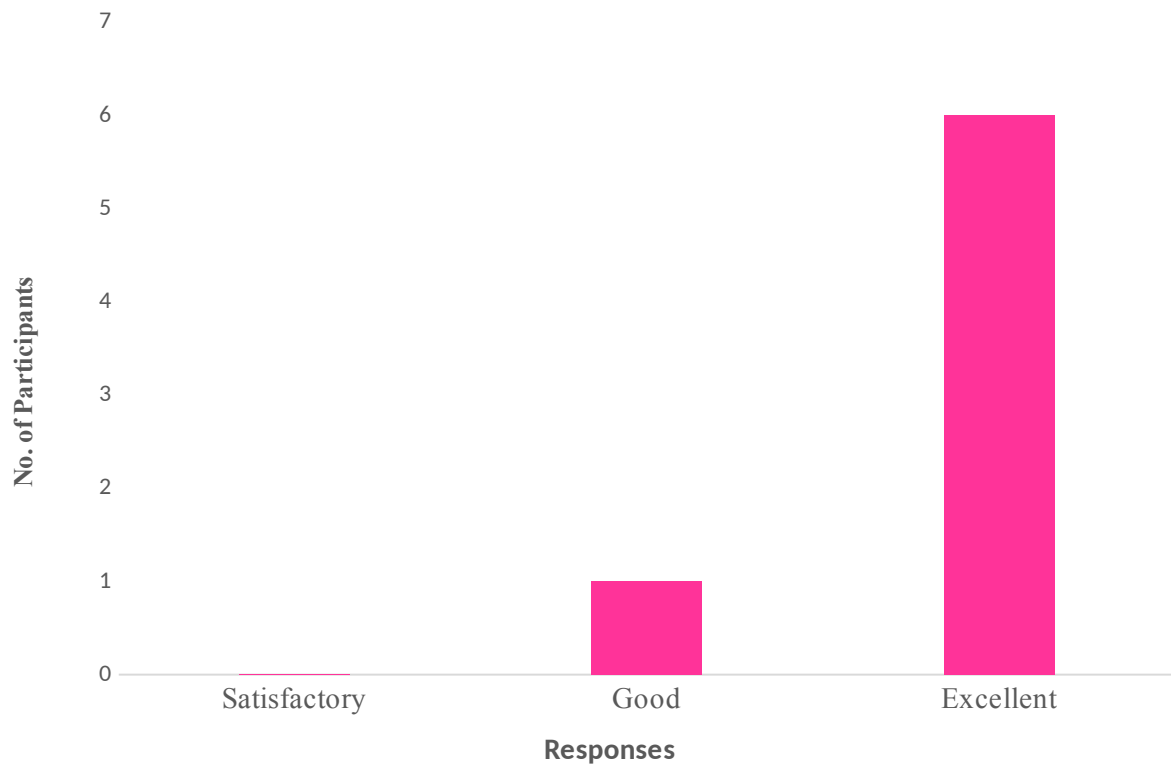

A Field Excursion-2023-24 Feedback Q.5-Benefits of Program



Dr A A Halder
Coordinator, IQAC
Science College,
Congress Nagar, Nagpur

Prof. M. P. Dhore
Principal
Science College,
Congress Nagar, Nagpur





GEOLOGY REPORT (2023-2024)



**SHRI SHIVAJI SCIENCE
EDUCATIONAL SOCIETY AND
JUNIOR COLLEGE**

GEOLOGICAL FIELD EXCURSION TO PARSHIVNI BY

Department of geology

2023-2024

6TH MARCH 2024

**IN THE GUIDANCE OF
MR. MAHESH PHALKE**

(HEAD OF THE DEPARTMENT, GEOLOGY)

AND

**MRS. PUSHPA ZAMARKAR
(ASSISTANT PROFESSOR)**

MISS. APURVA FULADI (ASSISTANT PROFESSOR)



• **SUBMITTED BY:-**

BSC 3RD YEAR (6TH SEMESTER)

REPORT PREPARED BY :-

FALGUNI VINOD KUMBHRE

SUBMITTED TO

MR.MAHESH PHALKE SIR

(HEAD OF THE DEPARTMENT)

[GEOLOGY]

ACKNOWLEDGEMENT

- At the very outset we express our deep sense of gratitude to Mr. Mahesh D. Phalke, Head of Department of Geology, to choose a comfortable place for field work and permitted us to complete our field tour in a good manner.
- We are very thankful to Mrs. Pushpa Zamarkar and GSI Sir to guide us the useful information about during the field work.
- We are very thankful to all the staff members, who supported us and provide necessary help during the entire tour.
- At last, we are thankful to our colleagues for their kind cooperation and encouragement during the tour and everyone who is directly or indirectly helped us.

- **Date : 5 MARCH 2024**
- **(sem 6)**
- **Place : Nagpur**
- **SHRI SHIVAJI SCIENCE COLLEGE**

**SCIENCE COLLEGE CONGRESS NAGAR,
NAGPUR, MAHARASHTRA (INDIA) –
440012**



Department Of Geology (2023 -2024)

CERTIFICATE

This is an to certify that “FIELD STUDY REPORT OF “
PARSEONI” submitted to Department of Geology,
SHRI SHIVAJI EDUCATION SOCIETY AMRAWATI
SCIENCE COLLEGE, Nagpur, embodies the result of
the literature field work carried out by the students
of Bsc Third year (6TH semester)

Mrs.Pushpa Zamarkar / Miss. Apurva Fuladi
Mr.Mahesh D.Phalke
(Tour Incharge)

Mr.Mahesh D.Phalke
(Head Of Department of Geology)
(Department of geology)

INDEX

SR NO.	NAME OF THE CHAPTER	PG No
01.	Introduction Purpose of Field Accessibility Location	06- 10
02.	Geology Aims & objectives About the Area	10- 14
03.	Methodology Brunton Compass Geological Hammer Stratigraphic succession of parshivani	14- 17
04.	Geology of the Area SPOT 1 : Topographic map SPOT 2 : Weathered Gneiss SPOT 3 : Eroded Biotite Gneiss SPOT 4 :Marble SPOT 5 :Z-type fold SPOT 6 : Marble with pegmatite intrusion SPOT 7 : Penicontemporaneous structure CONCLUSION	17- 33



INTRODUCTION

- Geology which deals with the study of rocks, and of the way they are formed. It demands passionate understanding and learning. We can get theoretical knowledge by readings but practical knowledge can only be gained by practical perceptual observation.
- Purpose of tour
- Accessibility to the locations
- Location of study area.
- Starting our tour on 6 March 2024 we visited an Parshivani . We studied general things about the rocks following that we went to learn about different types of rocks , fold belt ,map ,toposheet and topographic feature, biological weathering



Purpose of tour :-

- **Tour or excursion is a journey by a group of people to a place away from their normal environment. The purpose of tour is usually observation for education research or to provide students with experiences outside their everyday life activities such as going camping with teachers and their classmates. The aim of this tour was to observe the subject in its natural state and possibly collect samples. It is seen that more advantage children may have already experienced cultural institutions outside of college thus field tour provide a common ground with more advantage and less advantage children to have some of the same cultural experiences and educational well being. Depending upon the objectives of studies there are numerous methods of fields investigations. However there are certain basic procedures that we have to adopt. Since the main purpose of our tour this tour was to observe the geology of area**

Accessibility :-

Our tour started on morning of 6 march we all gathered at our college premises at 8.00 am and departed for parseoni at 8:15am by four wheeler. It was 34.8 km journey. We reached there at 11:30am and then GSI sir told us some basic things about topograghy, hill , rock Within half an hour and after discussing the basic things we began our journey again through the bus which was organize by the authority.

Midway we saw the different types of rocks. It took almost half an hours and after that we were going to salai saw a different types of rock . And by 4:30pm we go to Ghogra mahadev we departed for Nagpur 6 pm and by 7:45pm we reach Nagpur.



Location of Area:-

Parseoni (salai) is located in Nagpur District in the Vidarbha Region of the Indian of Maharashtra.

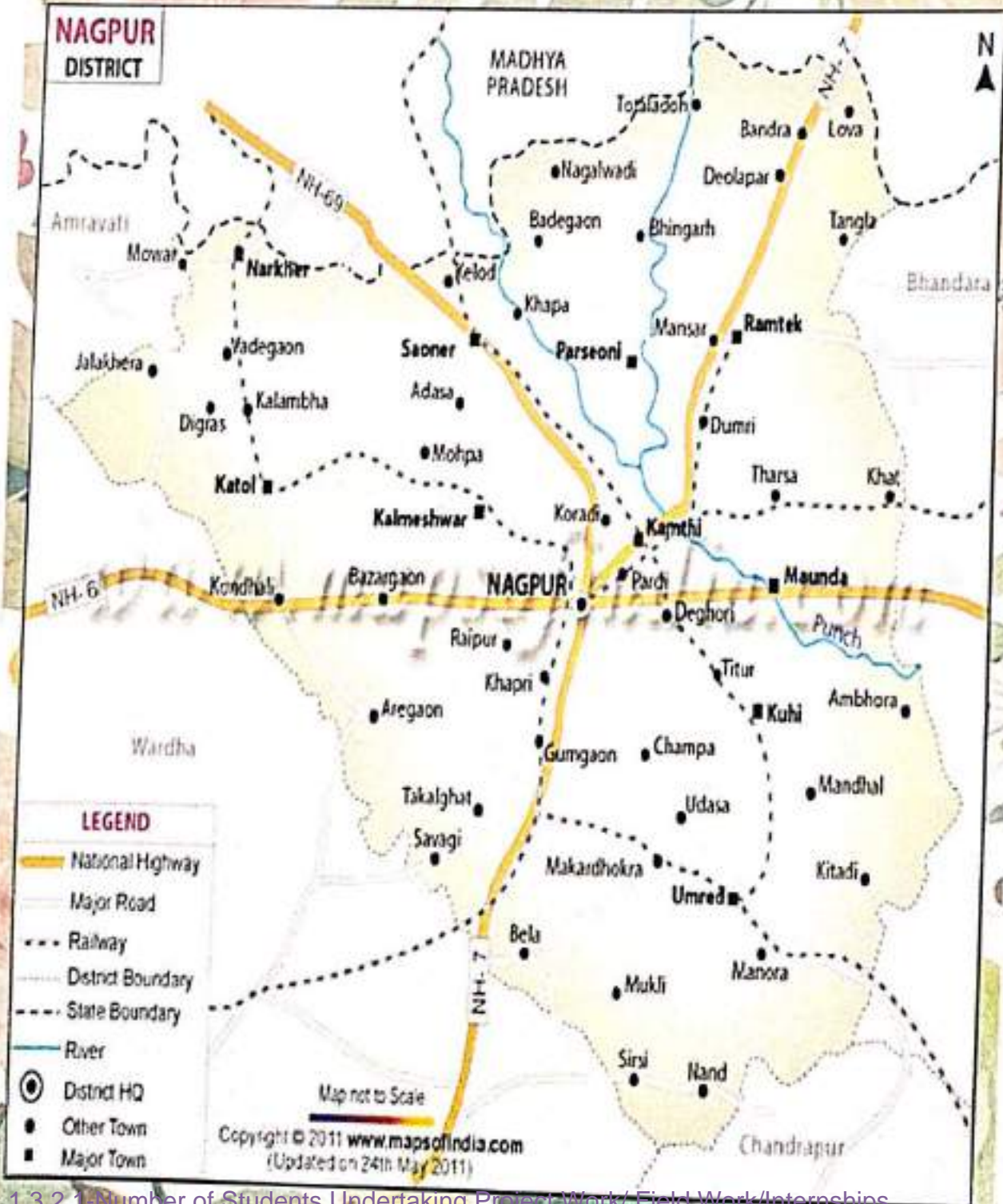

GEOLOGY

- Parseoni is located at 21.23'N 79.09'E. It has an average elevation of 310 meters . It is located at a distance of around 34.8 km from Nagpur.
- **Physiography :** The study area in general is gently undulating plain with isolated positive landforms. The area is extensively covered with soil and remains under thick cultivation. A few laterite exposures in the form of capping are also seen scattered in the area .The overall trend of the sediment core of the Parseoni signify the increased rate of soil erosion and enhanced nutrient concentrations in the recent units at the top owing to accelerated anthropogenic activities and likely to be multiplied in coming years with serve Modifications in the landscape pattern .
- Geologically, the Nagpur area has been represented by the rocks of the Archean age, the Lower Gondwanas , the Lametas , the Deccan Basalt associated with intertrappeans and alluvium. The ramtek is surrounded by the granitic gneiss with migmatite and granite of the Tirodi gnessic Complex Group of the archean to Paleoproterozoic age and quartzite and quartz muscovite schist of the sausar Group of the mesoproterozoic age. A collected sediment core was cut into the equal halves for the lithological and paleolimnological studies.
- The gneisses and fold belt area have been involved in folding of three generations. The fold of the first phase(F1) are isoclinal with an axial planar cleavage. Superposition of tight to isoclinal upright folds (F2) with WNW – ESE – striking axial planes on the early isoclinal folds has resulted in a boomerang – shaped map pattern of the area. The structure of the third generation are represented by gentle wraps (F3) with N- to NNE – striking axial planes. The arcuate shape of the sausar belt is a result of this F3 folding. The complex structural geometry of the area invalidates the stratigraphic successions proposed by earlier workers.
- Geological mapping and structural analysis of the manganese-bearing Sausar group and associates rock in Parseoni area, Maharashtra, have led to reinterpretation of stratigraphy and structure. A local stratigraphy successions for the Sausar supracrustal rocks, giving due weightage to lithologic criteria and structural considerations, has been proposed which is different from the existing divergent lithostratigraphic successions. The lithologic unit interpreted as a conglomerate horizon, near the contact of the granite gneiss and the Sausar group in this area, has been reinterpreted to be of tectonic origin, Sausar Group Preserves evidence of four generations of folding

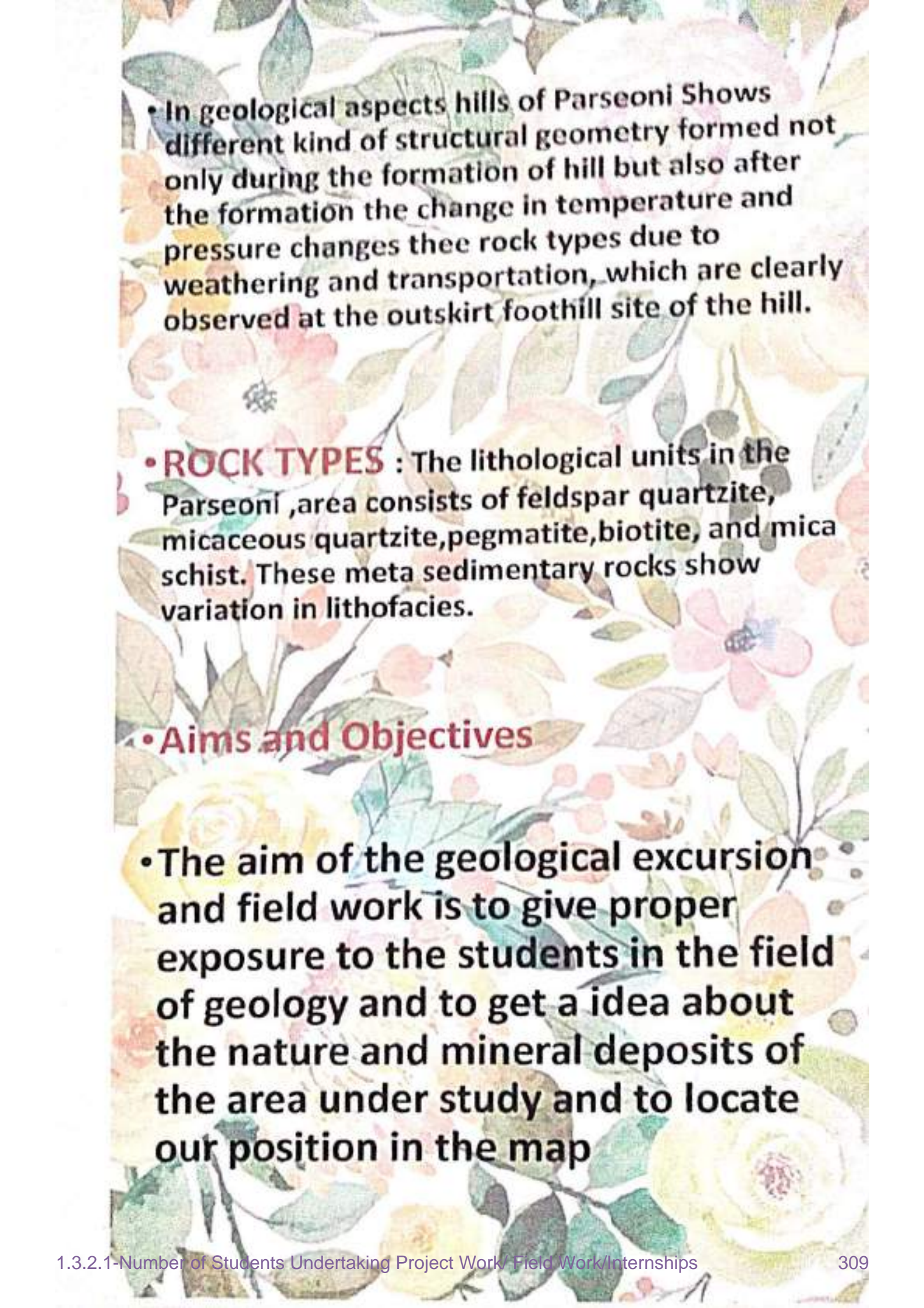

- In geological aspects hills of Parseoni Shows different kind of structural geometry formed not only during the formation of hill but also after the formation the change in temperature and pressure changes the rock types due to weathering and transportation, which are clearly observed at the outskirts foothill site of the hill.

- **ROCK TYPES** : The lithological units in the Parseoni ,area consists of feldspar quartzite, micaceous quartzite, pegmatite, biotite, and mica schist. These meta sedimentary rocks show variation in lithofacies.

- **Aims and Objectives**

- The aim of the geological excursion and field work is to give proper exposure to the students in the field of geology and to get a idea about the nature and mineral deposits of the area under study and to locate our position in the map



Objectives of geological field :-

- **To study the topographic map and different structure on the different scale**
- **To get details about geology of the area**
- **To predict the past geological history an environment on the basis of lithology , structure and other important things**

About the Study Area:-

Parseoni is a fine confluence of devotion, literature and history.

- The region of Parseoni, which is around 57 kilometer from Nagpur, the central city of India, is replete with ancient tradition and exploits of bravery. The Ramgiri hill is moderate height (113m). Parseoni is an important and popular tourist centre as the tiger sanctuary nearby, places of worship and recreation enhance its important as a tourists spot.
- Detailed structural mapping near Parseoni shows that the rocks of the area have taken part in folding of three generations. Superposition of upright F2 folds with ESE – striking axial planes on isoclinal F1 folds has resulted in a map pattern of type 2 interference.
- The rock of Mahuli- Parseoni area have a synclinal structure with both the limbs showing a normal order of superposition is untenable because of the following reasons : (a) The regional fold referred to as “Mahuli – Parseoni syncline” is a second generation structure near Parseoni. To establish stratigraphic order in such a structure, the disposition of the early folds should be studied carefully. (b) Near Parseoni, the quartzite bands show stratigraphic younging toward the core at one place on the southern limb of the synform, but the younging is away from the core at a place on the northern limb
- The stratigraphic Succession given by these workers therefore does not stand critical scrutiny

- **METHODOLOGY**

- **Brunton Compass**

- A compact pocket instrument that consists of an ordinary folding open sight, a mirror, and a rectangular spirit-level clinometers, which can be used in the hand or on a staff or light rod for reading horizontal and vertical angles, for leveling, and for reading the magnetic bearing of a line. It is used in sketching mine workings, and in preliminary topographic and geologic surveys on the surface. e.g. in determining elevations, stratigraphic thickness, and strike and dip.



TOP VIEW

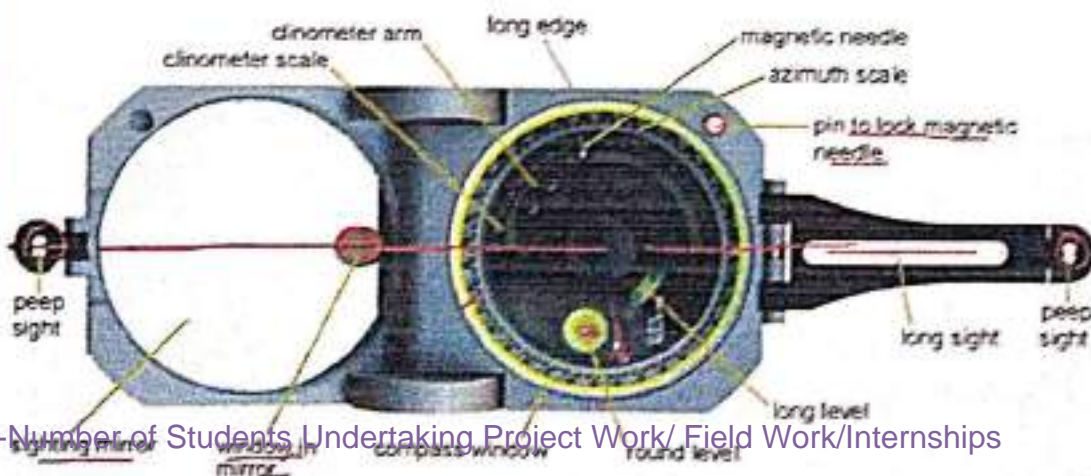

• Geological Hammer

- A geologist's hammer, rock hammer, rock pick, or geological pick is a hammer used for splitting and breaking rocks. In field geology, they are used to obtain a fresh surface of a rock to determine its composition, bedding orientation, nature, mineralogy, history, and field estimate of rock strength. In fossil and mineral collecting, they are employed to break rocks with the aim of revealing fossils inside. Geologist's hammers are also sometimes used for scale in a photograph. The hammer also serves as an extension of the senses. Permitting the geologist to perceive the rock's granularity, soundness, and resistance to fracturing that may be relevant to its use or identification.



• **Stratigraphic succession of the Parseoni area, Nagpur district, Maharashtra**

- Stratigraphic succession area of the parseoni ,the sausar group belt involves the stratigraphic position of various formations of the sausar group.precambrian metasediments of parseoni area belong to the sausar group .these comprise of the quartzite ,micaschist with manganese ore and marble .the metasediments of the area show evidence of three phases of folding.
- The early folds (F1) are isoclinal with an axial planar cleavage (S1).
- The second fold(F2) are tight to isoclinal with axial Panar crenulation cleavage (S2).
- These (F2) folds have EW striking vertical axial planes and cngrows pucker axis lineations.
- The third fold(F3) are open upright with NS striking axial planes.
- An antiformal F2 fold plunging E is mapped in the area.
- The absence of any primary top and bottom criteria the stratigraphic succession for the area suggested by earlier worker

• GEOLOGY OF THE AREA

- Structural patterns in the sausar group around mansar parseoni area :
- The Precambrian rocks of the mansar area, Nagpur district, Maharashtra, belong to the sausar group and the Tirodi Gneiss. Both these lithological units show an unconformable relation in the area, marked by a conglomerate at the base of the sausar group. Detailed mapping of the sausar group around kandri mines, shows that the rocks of the area have been involved in folding of three generations. The metasedimentary bands in the kandri mines and the surrounding area show an arcuate outcrop that closest northwest.
- Structural stratigraphic relations in Precambrian rocks of sausar belt, the sausar group of paleoproterozoic age comprises a thick sequence of carbonate quartzite-psamopelitic rocks. These rocks have undergone polyphase deformation. The regional E-W to ENE-WSW alignment of the belt is found to be the effect of second deformation.

• SPOT 1 : TOPOGRAPHIC MAP

- • Which it is said $1\text{cm} = 25000\text{m}$ that means $1\text{cm} = 250\text{m}$ and $1\text{cm} = 50,000$ that means $1\text{cm} = 500\text{ m}$.
- • Linear scale can be adjusted according to our need $2\text{cm} = 1\text{km}$ and $1\text{cm} = 500\text{m}$.
- • Longitude from west to east and latitude from south to north.
- • Area can be calculated as length x Breadth.
- • Each toposheet more or less occupy 72 sq km .
- • In $550/3$ 550 represents degree sheets which consist of 64 toposheet and $0/3$ represent toposheet consist 16 parts.
- • Map are made according to contour.
- • 1 contour do not intersect with other contour.
- • C All can see parseoni on the map and then we went toward to kahnadevi temple ontour interval depend upon area to area.
- • We can also see water bodies on map.
- • We can locate ourself on map in two opposite sides for which use brunton compass

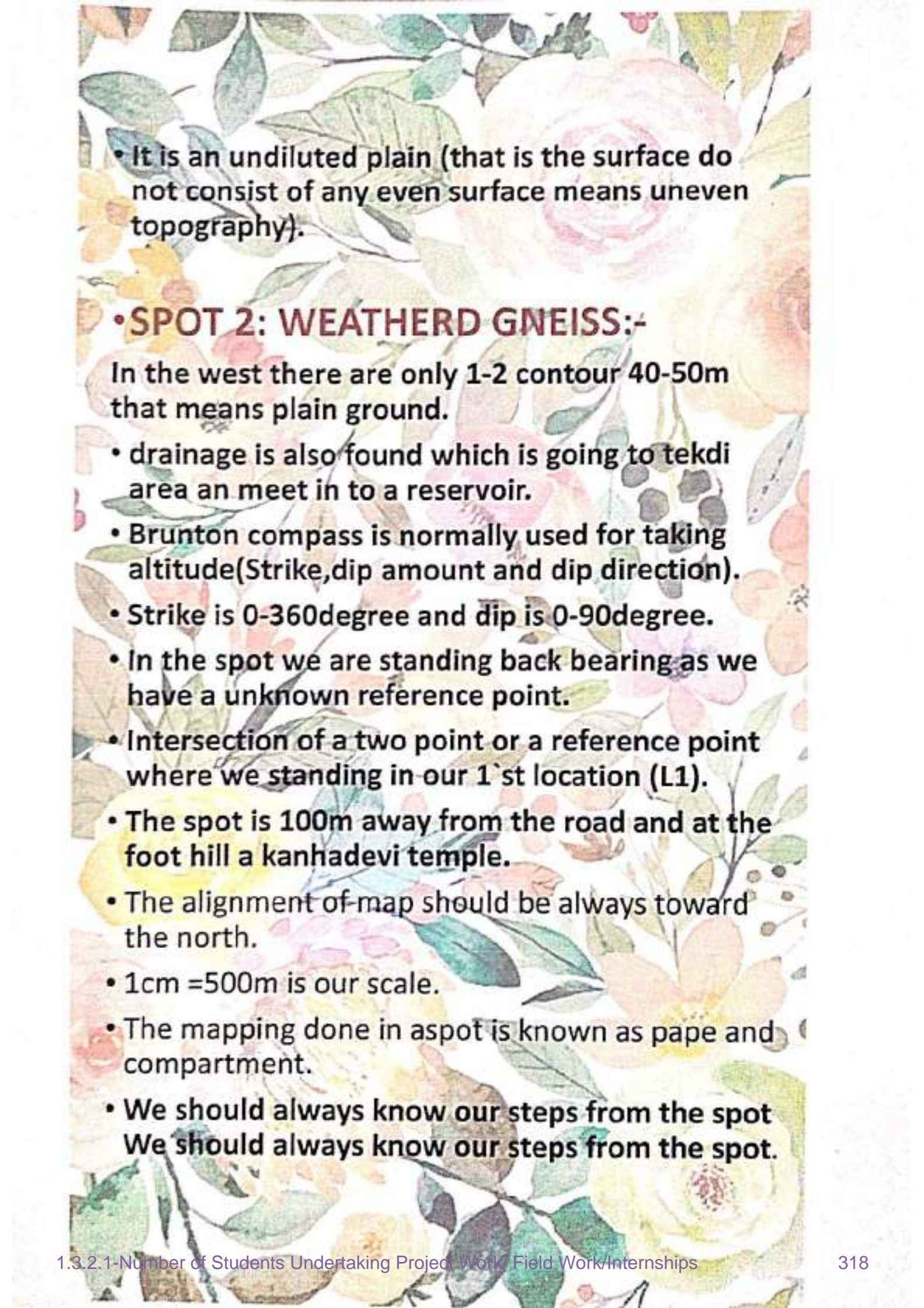

- 
- It is an undiluted plain (that is the surface do not consist of any even surface means uneven topography).

• **SPOT 2: WEATHERD GNEISS:-**

In the west there are only 1-2 contour 40-50m that means plain ground.

- drainage is also found which is going to tekdi area an meet in to a reservoir.
- Brunton compass is normally used for taking altitude(Strike,dip amount and dip direction).
- Strike is 0-360degree and dip is 0-90degree.
- In the spot we are standing back bearing as we have a unknown reference point.
- Intersection of a two point or a reference point where we standing in our 1`st location (L1).
- The spot is 100m away from the road and at the foot hill a kanhadevi temple.
- The alignment of map should be always toward the north.
- 1cm =500m is our scale.
- The mapping done in aspot is known as pape and compartment.
- We should always know our steps from the spot
We should always know our steps from the spot.



SPOT 3: ERODED BIOTITE GNEISS :-

- The basement oldest rock formation.
- Its age is proterozoic era and consist of sausar sediment as diposition.
- Its basin consist of meta-sediment such as carbonate, phyllite, schist, etc.
- due to deposition of meta sediment fractures are created and hydrothermal materials are channelized through this ruptures and part of sediments are flows with it.
- So the contact between basin and oldest rocks are called as thrust cntact or intrusive contact.
- When the basins are firstly formed in them are conglomerates (sedimentary rock).
- The south of the area consist of volumetric conglomerate that means the material has come from and means the materials has come from south and deposit towards the north.
- It means in the anging direction of the basin anger river rack is found.
- First archean rock is found known as phenotic peiotite gneiss which come from sausar sediment.
- The first formation on sausar sediment is conglomerate, quartz, mica, shist and the basement of basin is archean i.e , phenotic biotite gneiss .
- It is chor bawali formation and consist of quartz mica schist .
- Dip = 299° .
- Strike = $N61^\circ W$.
- Dip direction = $29^\circ NE$.

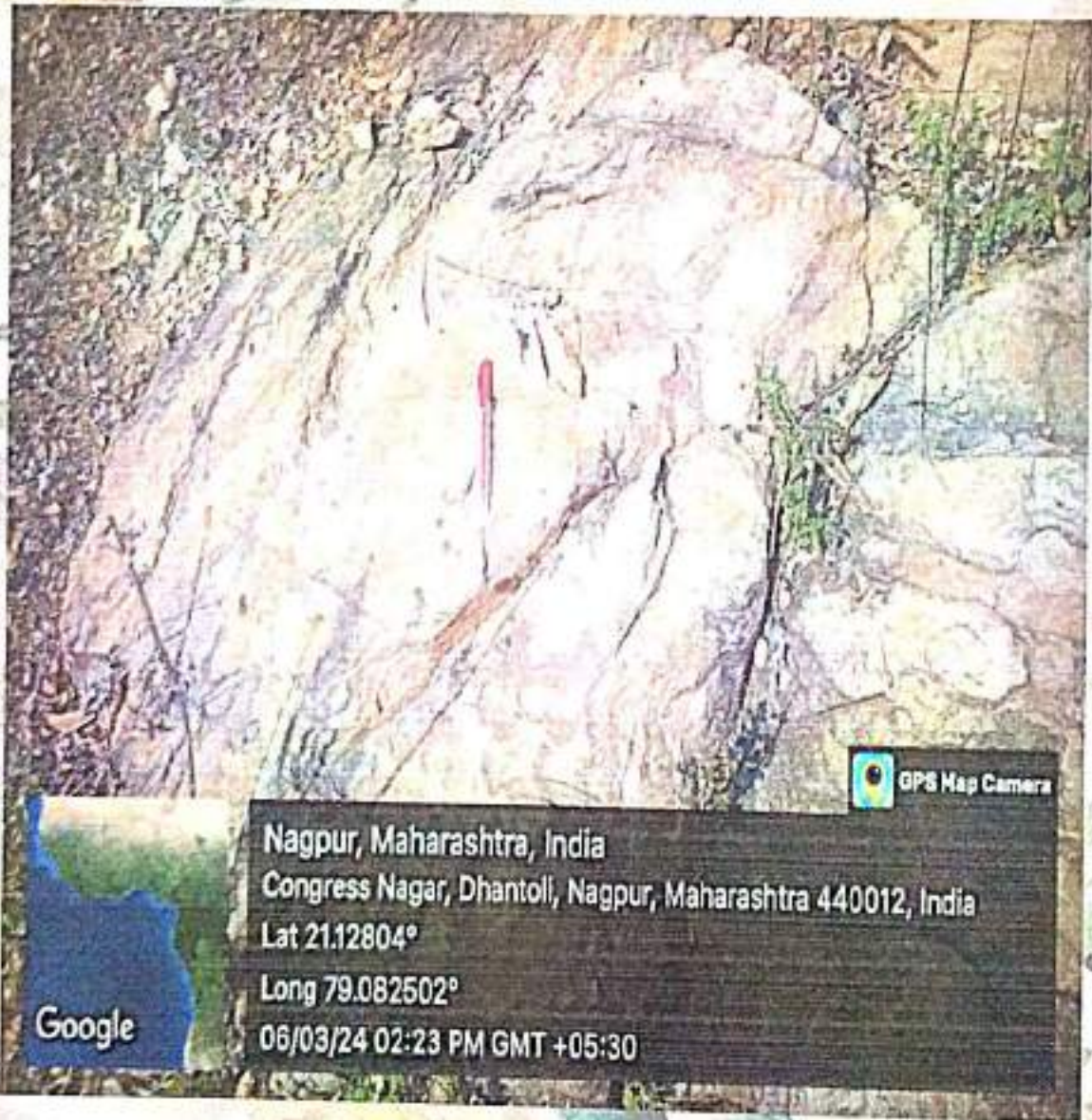

SPOT 4: MARBLE :-

- The oldest rock is pegmatite ,biotite gneiss complex of archean age. The sausar basin started early proterozoic age.
- The first formation is sita sawanghi→ mansar→ chor bawali→ Junevani →bichua .
- Mineralization part sausar is found in down of mansar i.e manganese horizon 1 and in mansa i.e manganese horizon 2. but the garnetiferous manganese i.e manganese horizon 1 is found in mansdar which is economically viable.
- Oldest rock of archean age s shown by + sign.
- We can see magnese in this spot of black colour of lowhangi formation in marble rock and can be scratched by nail or acid can be putted on it.

The rocks found down of mansar is lowhangi which means it is the oldest.

Basin enclosed towards the north direction because material is supplied from south direction . The manganese in lowhangimarble come fromsyngenetic sediments i.e. silica replaced from MnO_3 .

- Manganese consist of so much of impurities that Fe and Mg are removed and only silica is found.



SPOT 5:- Z-Type fold:-

- **Definition – Folds are wave like structure that the result form deformation of bedding ,foliation,or other originally planar surface in rock.**
- **Antiform structure**
- **Plunge direc tion**
- **Left limb Z-form**
- **In right limb S-Form**
- **Z and S –fold are three dimensional structure and will have hinge lines (or fold Axes if we consider them to be cylindrical folds). An axial surfaces that can be measured.**
- **Our view indicates the left outcrop is a Z-fold , the one on the right S-fold.**
- **We can also determine the general attitude of the first order fold limbs from dip and strike on associated beds.**
- **If 1st order fold closure is beneath the surface ,then it is syncline if above ,an anticline or antiform.**
- **If the structure was a syncline then the vergence should be in the opposite direction.**
- **structure is therefore an antiform.**
- **If we have good falling direction confirm 1st order structure ia an overtuned anticline.**
- **The difference between S and Z-folds lies in their sense of rotation or vergence.**
- **The long limbs of S-fold are connected by a shorter limb that implies counter clock wise rotation or sense of diasplacement ;the opposite applies to Z-fold.**
- **The vergence of paracitic fold is towards the honge line (or zone).**
- **Z-type fold are developed in thrust or reverse fault.**
- **Z-type shows thrustsed ,dip is north thrust or reverse also called as dip fault.**
- **Antiformal syncline –have a syncline character younger rock in core older rock on limb syncformal anticline have a anticlinal character younger rock of the limb older**

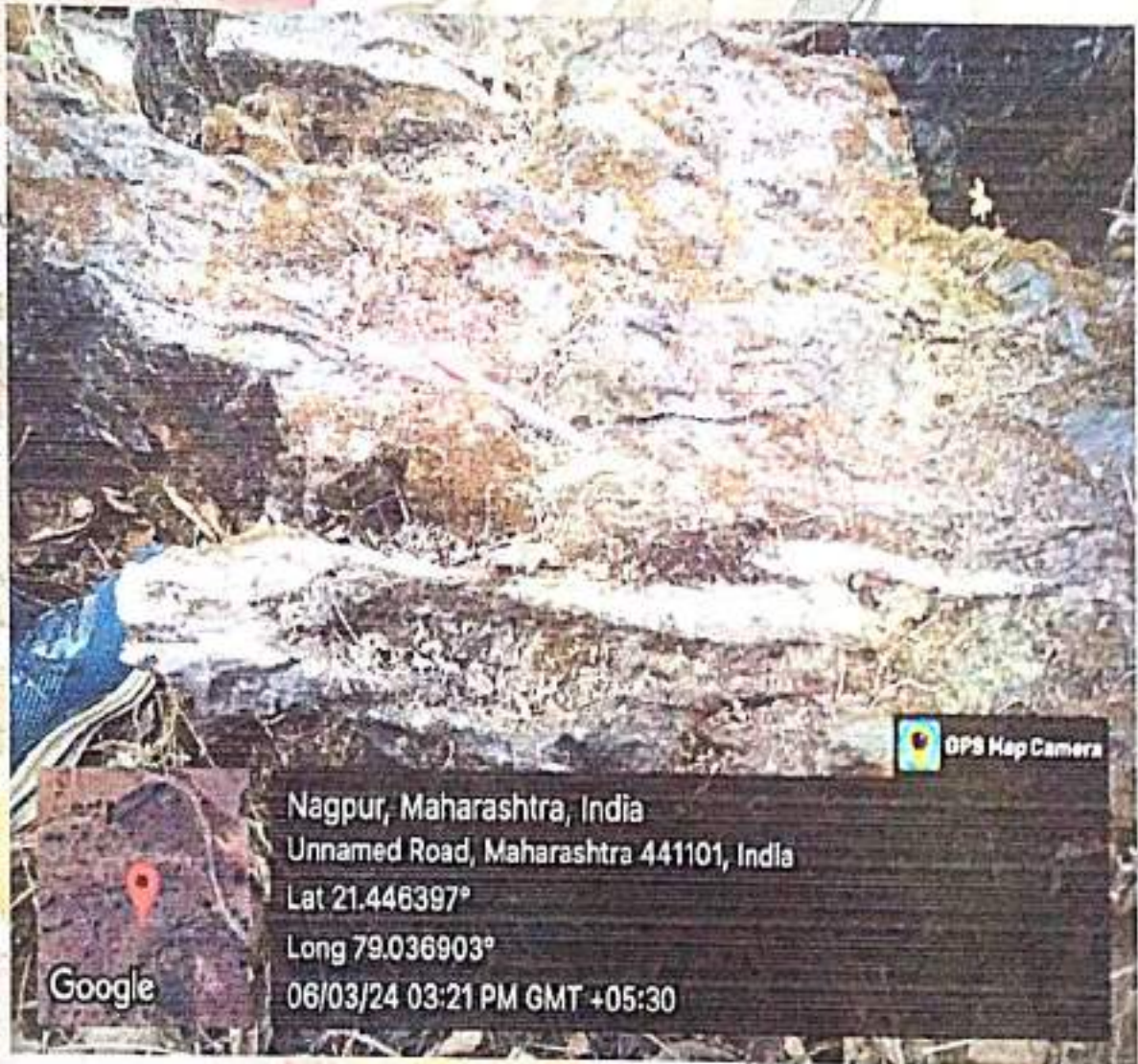

• SPOT 6 : MARBLE WITH PEGMATITE INTRUSION :-

- A pegmatite is an igneous rock showing a very coarse texture with large interlocking crystals usually greater in size than 1cm and sometimes greater than 1 meter. Most pegmatites are composed of quartz, feldspar and mica having a similar solid composition of granites
- The zero fault pegmatite is a large unzoned pegmatite or graphic granite that is well exposed.
- The geochemical data has facilitated development of a three step process responsible for its origin.
 - 1. Anatectic partial fusion of a potassic metarhyolite most of the resultant anatectic melt phase recrystallized in situ to form the leucosome of the microcline gneiss, but some plots between the 720 ° and 730 ° c. Isotherm of the 500Mpa phase. Some relaxation and cooling from peak condition.
 - 2. Intrusion of mt.eu granite into arble layers, during which the anatectic melt underwent dense mineral. Fractionation, resulted in the formation of the zero fault pegmatitic fault.
 - 3. The melt encountered CO₂ vapours, which reduced H₂O activity, increased solid as temperature and resulted in significant under cooling.
- The latter led to rapid-crystallization (at 720 °c to 740 ° c) leading to development of a quenched graphic texture.
- While emplacement of graphite granite into arble is common among pegmatites.
- Pegmatite is a type of igneous rock that is characterized by its coarse grains and large interlocking crystals.
- Pegmatite is an intrusive igneous rock which means it forms, solidifies and crystallized beneath earth surfaces.
- Pegmatite forming magma also have a low viscosity unlike other intrusive igneous rocks.



• SPOT 7 :- PENECONTEMPORANEOUS STRUCTURES :-

- A geological phenomenon originally or effectuated during or soon after the formation of the rocks in which it is displayed.
- Definition :- the fold and faults formed during slumping are called penecontemporaneous.
- Penecontemporaneous means that they formed almost (hence "pene") at the same time as the original deposition of the layers.
- Penecontemporaneous folds and faults are characteristically chaotic.
- They are infraformational i.e bounded above and below by relatively undeformed strata.
- Sediments may be deposited with a gentle initial dip. In this case, gravity may pull them down during storm or earthquake. the downslope movement is helped by fluid pressure.
- Deposition on a preexisting slope or tilting prior to full lithification in a tectonically active region can pull the layer down the slope.
- Fluid pressure in the layers keeps the layers apart.
- If sediments that move down the slope are soft, they may produce a slurry of clasts suspended in a matrix called debris flow. When the debris flow comes to rest, it forms a poorly sorted, conglomerate.
- If the sediments are dislodged by gravity. they maintain their cohesion and produce what is called slumping.
- The deformed interval is intraformational meaning that it is bounded both above and below by relatively undeformed strata.





• CONCLUSION : -

At Parshivani, we observed various types of rocks such as mica schist, quartzite, manganese, marble, and also various types of folds like symmetrical fold, etc.

We learnt about the various characteristics of these rocks which was beneficial for us as it forms a part of our syllabus.

\The trip of Parseoni also gave us idea of conducting field work and the various aspects of field work such as sampling of the rocks, drawing geological field diagrams etc.

All in the trip to Parseoni was a fruitfull one





THANK
YOU



**Shri Shivaji Education Society Amravati's
Science College Congress Nagar, Nagpur
Department of Zoology
Session: 2023 - 2024**

Report on visit to NEERI on 4/10/23

On the occasion of CSIR foundation day, National Environmental Engineering Research Institute (NEERI), Nagpur had organized science model exhibition-cum-competition and the significant R&D achievements/ ongoing activities was briefed at the respective laboratories of the institute on 29/9/23 and 4/10/23.

Students of Department of Zoology, Shri Shivaji Science College, Congress Nagar, Nagpur Visited NEERI, Nagpur on 4/10/23. There was total 25 students along with 2 faculty of PG Zoology, Ms. Khushboo Sheikh and Dr. Shilpa Katre. after entering the institute registration was done and refreshment boxes was provided to the students. Students were then allowed to see the science model exhibition where various students from class 6th to 12th had displayed their models.

Various laboratory of NEERI, was also open for the students where the research scholars have given a brief information about the instruments and various ongoing research projects to the students. Students got to know about various useful information and different fields of Life Sciences.

HOD

Prof. A.D. Bobey

Dr. A. D. Bobey
Professor & Head
Department of Zoology,
Shri Shivaji Science College,
Congress Nagar, Nagpur-12.

Convener

Dr. S.G. Kadu



UG & PG students visited NEERI on 4/10/23



Science exhibition model



B.Sc. Sem I Students



Demonstration on air pollution controller



Visit to Biotechnology lab

LETTER FROM NEERI



सी.एस.आई.आर. - राष्ट्रीय पर्यावरण अभियांत्रिकी अनुसंधान संस्थान
CSIR - National Environmental Engineering Research Institute

(वैज्ञानिक तथा औद्योगिक अनुसंधान परिषद / Council of Scientific & Industrial Research)

(वैज्ञानिक तथा औद्योगिक अनुसंधान विभाग, विज्ञान एवं प्रौद्योगिकी मंत्रालय, भारत सरकार के अंतर्गत स्वायत्त संगठन) NEERI
(Autonomous Organization under the Dept. of Scientific and Industrial Research, Ministry of Science & Technology, Govt. of India) 0001/2008



सेवा: निदेशक, नीसी
From: The Director, NEERI

Office of the Principal
S. S. E. S. Amravati's
Science College, Nagpur.

Inward No. 5896 Dt. 21/09
2023

Sign.....

PRMMG/CSIR-NEERI Foundation Day /Miser 2022-23
18 September 2023

To,
Principals
Schools / Colleges

Sub: Participation of schools/colleges in CSIR-NEERI Foundation Day celebrations at NEERI - confirmation reg.

Dear Sir / Madam,

I am pleased to inform that 82nd CSIR Foundation Day celebrations will be held at National Environmental Engineering Research Institute (NEERI), Nagpur on 4th October 2023 (Wednesday). The Institute will be kept opened between 10.30 am to 2.30 pm on this day for students. The significant R&D achievements / ongoing R&D activities will be briefed at the respective Laboratories of the Institute on this day.

Science model exhibition-cum-competition for students will also be organized as per the following.

29.09.2023 (Friday) 11.00 am - 12.30 pm Evaluation of science models.
(The participating students need to bring their models on 29.09.2023 for evaluation)

04.10.2023 (Wednesday) 10.30 am - 2.30 pm Inauguration of the exhibition by the dignitaries
(The models will be kept at NEERI till 4.10.2023 as the models will also be displayed on 4.10. 2023)

May I request you to kindly confirm the participation of students in this science model exhibition-cum-competition. The students will get an opportunity to display their innovation and creativity in the areas of air pollution control, water technology and management, waste management, etc. Each school will be allowed to present one science model only, in each category, i.e. Category I: students studying in 5-7 standard, Category II: 8-10 standard, and Category III: students studying in 11-12 standard. There will be three prizes in each category. The science model exhibition-cum-competition will exclusively be focused on the environment. The participating students may display their skill towards betterment of the environment through development, innovation, creativity, etc. involving science and technology intervention.

Your school may also plan for visit of students to the Institute on 4 October 2023 between 11.00 am to 2.30 pm so that they can see various Laboratories of the Institute and interact with our scientists.

For circulation
Miser
21-9-23

name of the school, name of the science model, participation category, mobile number, number of visiting students, etc. at the contact details provided below.

While contacting and confirming, you are requested to kindly indicate your willingness as per the following:

1. Participation in science model exhibition-cum-competition (timings: 11.00 am – 12.30 pm on 29.09.2023 for evaluation and 10.30 am to 2.30 pm on 04.10.2023 for exhibition) – The participating students need to bring their models on 29.09.2023 for evaluation and the models will be kept at NEERI till 4.10.2023 as the models will also be displayed on 4.10.2023.

2. Students visit to NEERI Laboratories (timing: 10.30 am to 2.30 pm on 04/09/2023)

There is no fee for participation in the Science Model Exhibition-cum-Competition and visit to CSIR-NEERI. As refreshment packets will be given to the participating students, please inform us well in advance about the number of students visiting CSIR-NEERI latest by 27 September 2023 through e-mail given below.

Looking forward to your kind cooperation and participation in this regard.

Thanks and regards,

Yours sincerely



(Prakash Kumbhare)
Sr. Principal Scientist & Head
PRMMG, CSIR-NEERI

e-mail: prakashkumbhareneeri@gmail.com

Mob: 9423063927

PERMISSION LETTER TO VISIT NEERI ON 4/10/23

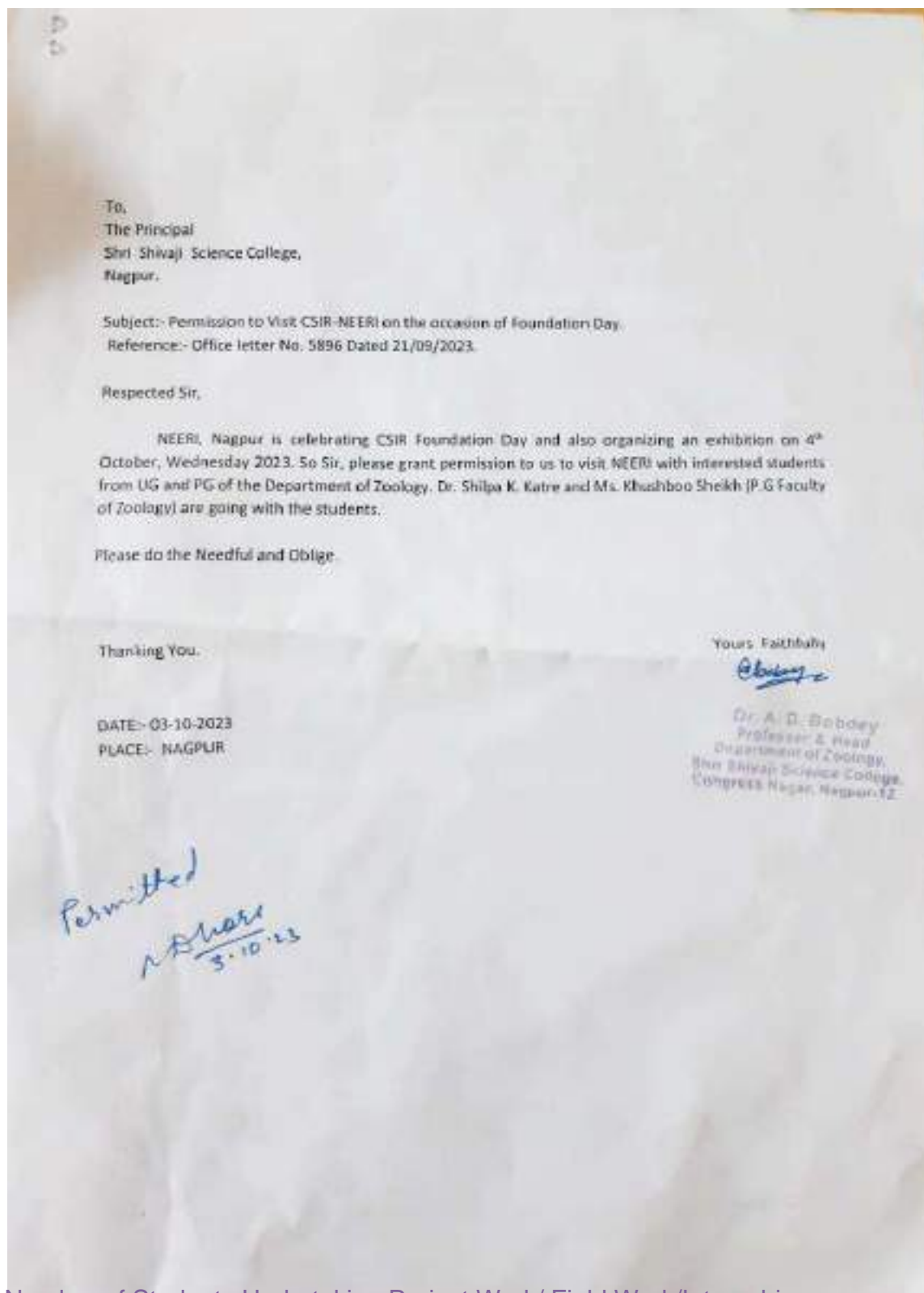

Shri Shivaji Education Society Amravati's
Science College Congress Nagar, Nagpur
Department of Zoology
Session: 2023 – 2024

NOTICE

Date : 2/10/23

All the students of UG/PG are here by informed that they have to visit NEERI on 4/10/23, so all the students should to be present In the zoology lab at 9.30 am.



Head
Prof. A. D. Bobdey



Convener
Dr. S.G Kadu

Dr. A. D. Bobdey
Professor & Head
Department of Zoology,
Shri Shivaji Science College,
Congress Nagar, Nagpur-12.

STUDENTS ATTENDANCE

VISIT TO CSIR-NEERI, NAGPUR

ON THE OCCASION OF FOUNDATION DAY

List of STUDENTS Participated in visits organized by the Department of Zoology,
S.S.E.S.A., Science College Nagpur.

S. No.	Name of students	B.Sc.(Zoo)	M.Sc. (course)	Sign.	Date
1.	Falguni. Y. Tichkar	B.Sc. V th (com)		[Signature]	
2.	YASH- S. Dhole	B.Sc III rd (Zoo)		[Signature]	
3.	Sanika V. Kante	B.Sc III rd (com)		[Signature]	
4.	Shruaddha Bante	B.Sc II nd (com)		[Signature]	
5.	Sanika Bhandar	B.Sc I st (com)		[Signature]	
6.	Mohak. Solanki	B.Sc II nd (CBZ)		[Signature]	
7.	Aarav. Bharambe	B.Sc III rd (Zoo)		[Signature]	
8.	Hanishini Kothre	B.Sc III rd (com)		[Signature]	
9.	Muwanali Kote	B.Sc III rd (Zoo)		[Signature]	
10.	Khushi. Baheti	B.Sc I st (com)		[Signature]	
11.	Laynesta. Gurnade	B.Sc I st (com)		[Signature]	
12.	Gauri. I. Dote	B.Sc I st (com)		[Signature]	
13.	Yashashree S. Maywat	B.Sc III rd (CBZ)		[Signature]	
14.	Shriyaja. Kalambe	B.Sc III rd (com)		[Signature]	
15.	Roshni. Dutt	B.Sc III rd (com)		[Signature]	
16.	Snega. Bhorgade	B.Sc III rd (CBZ)		[Signature]	
17.	Srushti. Patil	B.Sc III rd (com)		[Signature]	
18.	Anshu. Gaurish. Meshram	B.Sc V th (com)		[Signature]	
19.	Afija. M. Gandhukia	B.Sc V th (com)		[Signature]	
20.	Sajana. S. Mungu	B.Sc V th (com)		[Signature]	
21.	Umakanti. J. Rajel	B.Sc III rd (CBZ)		[Signature]	
22.	Gurjun. P. Sherkar	M.Sc I (Zoo)	M.Sc (Zoo)	[Signature]	
23.	Surbli. G. Kakale		M.Sc I (Zoo)	[Signature]	
24.	Shriya. P. Urkude		M.Sc I (Zoo)	[Signature]	
25.	Kshatna. S. Bante		M.Sc I (Zoo)	[Signature]	
26.	Nikita. P. Dhole		M.Sc I st (Zoo)	[Signature]	
27.	Rishi. Kote		M.Sc I st (Zoo)	[Signature]	

Shri Shivaji Education Society Amravat's

Science College

Congress Nagar Nagpur

CERTIFICATE

DEPARTMENT OF BOTANY

This is certify that the project report on “ Shiv tekdi , Ghogra mahadev , Pench dam” has been carriedout by the students of B.sc. 1st year (CBZ) during the academic year 2023-2024 .



Signature of the teacher



Prof. R. N. Deshmukh

HEAD
DEPARTMENT OF BOTANY
SHRI SHIVAJI EDUCATION SOCIETY
AMRAVATI'S SCIENCE COLLEGE
CONGRESS NAGAR, NAGPUR

Head of Department

ACKNOWLEDGEMENT

We are very thankful to our Hon'ble principal Dr. M. P. Dhore sir and HOD Dr. R. N. Deshmukh sir for allowing us to have a wonderful experience to acquire knowledge without teacher in the joyful surrounding .

We are also very thankful to our teacher of our Botany Department especially in-charge Dr. Reshma Sonwalkar mam and Dr. Sharayu Deshmukh mam as well as Non – teaching staff members of Botany department who made this paper presentation possible as well as memorable.

- 1] Poonam Dubey
- 2] Manisha Dehankar
- 3] Tanushree Jadhav
- 4] Gayatri Bhise
- 5] Sangita



Submitted to :- Dr. Reshma Sonwalkar / Dr. Sharayu Deshmukh

CONTENT

- INTRODUCTION
- ACKNOWLEDGEMENT
- SHIV TEKDI
- PENCH DAM
- GHOGRA MAHADEV
- FLORA
- BILIOGRAPHY

SHIV TEKDI , PARSHIVNI

INTRODUCTION :-

Shiv Tekdi, Parshivni is a hindu temple located in Parshivni, Maharashtra. The average rating of this place is 4.00 out of 5 stars based on 46 reviews. The street address of this place is 95J5+3R8, Parshivni, Maharashtra 441105, India. It is about 5.98 kilometers away from the Amdli railway station.

Origin : Nagpur

Destination : Shiv tekdi , parshivni

Distance : 47 km

Driving time : 1 hours



PENCH DAM AND RESERVOIR

INTRODUCTION :-

1.3.2.1. Number of Students Undertaking Project Work/ Field Work/ Internships 346
Kamthikhairi Dam, also called PENCH Dam, is on the [Pench river](#) near

Parshivni in the state of Maharashtra, India. The dam was constructed for irrigation, and supplies water to two districts of Maharashtra ,[Nagpur](#) and [Bhandara](#). The dam is located in the West [Pench National Park](#) Range, surrounded by forested hills, and is 54 km north of Nagpur. The tallness of the dam over its most reduced establishment is 32 m 105 ft while the length is 1,876 m 6,155 ft. The volume content is 4,928 km³ 1,182 cu mi and gross stockpiling limit is 230,000.00 km³ 55,179.93cu mi.

Origin : Nagpur

Destination : Pench dam and reservoir

Distance : 54 km

Driving time : 1 hr 30 min



GHOGRA MAHADEV

INTRODUCTION : Ghogra Mahadev is a Hindu temple dedicated to Lord Shiva, located in the Parshivni tehsil of Nagpur district, Maharashtra, India. It is a popular pilgrimage destination for Hindus, and is also known for its natural beauty. The temple is situated on a rocky hillock, and is surrounded by a maze of white rocks. A stream of water



Flows through the rocks, creating a beautiful waterfall. The shivling in the temple is believed to be a very powerful manifestation of Shiva. They pray for Shiva's blessings, and they seek his protection from evil. The temple is especially crowded during the Shivratri festival in February or March. Shivratri is a major Hindu festival that celebrates the night of Shiva's marriage to Parvati. During Shivratri, devotees fast and pray to Shiva. They also visit temples dedicated to Shiva, such as Ghogra Mahadev.

Origin : Nagpur

Destination : Ghogra mahadev

Distance : 47 km

Driving time : 1 hr 15 min

FLORA INTRODUCTION

In our recent study tour, we had the incredible opportunity to explore a diverse range of floral species in Shiv Tekdi, Penchand Ghoghra Mahadev.

1) *Barleria*:

Barleria is a genus of plants in the family *Acanthaceae*

Kingdom: Plantae

Clade:

Tracheophyte

sClade:

Angiosperms

Clade:

Eudicots

Order:

Lamiales

Family: *Acanthaceae*

Genus: *Barleria* L. (1753)



It is also called as Porcupine Flower Yellow Hedge *Barleria* in English

Some species are – *B. cristata*

B. prionitis *B. lupulina* , etc .

2) SOLANUM:

Solanum is a large and diverse genus of flowering plants, which include three food crops of high economic importance: the potato, the tomato and the eggplant (aubergine, brinjal). It is the largest genus in the nightshade family Solanaceae, comprising around 1,500 species. It also contains the so-called horse nettles (unrelated to the genus of true nettles, *Urtica*), as well as numerous plants cultivated for their ornamental flowers and fruit.



Solanum species show a wide range of growth habits, such as annuals and perennials, vines, subshrubs, shrubs, and small trees. Many formerly independent genera like *Lycopersicon* (the tomatoes) and *Cyphomandra* are now included in *Solanum* as subgenera or sections. Thus, the genus today contains roughly 1,500 to 2,000 species.

Kingdom:- Plantae
Clade:- Trycoephytes
Clade:- Angiosperm
Clade:- Eudicots
Order:- Solanales
Family:- Solanaceae
Genus:- Solanum

3) *CANNA INDICA*

Canna indica, commonly known as Indian shot, African arrowroot, edible canna, purple arrowroot, Sierra Leone arrowroot, is a plant species in the family Cannaceae. It is native to much of South America, Central America, the West Indies, and Mexico. It is also naturalized in the southeastern United States (Florida, Texas, Louisiana, and South Carolina), and much of Europe, sub-Saharan Africa, Southeast Asia, and Oceania.

Kingdom:-Plantae
Clade:-Tracheophytes
Clade:-Angiosperms
Clade:-Monocots
Clade:-Commelinids
Order:-Zingiberales
Family:-Cannaceae
Genus:-*Canna*
Species:-*C. indica*



3) *VERNONIA*



Vernonia is a genus of about 350 species of forbs and shrubs in the family Asteraceae. Some Species are known as ironweed. Some Species are edible and of economic value. They are known for having intense purple flowers. There have been numerous distinct subgenera and subsections named in this genus, and some botanists have divided the genus into several distinct genera. For instance, the Flora of North Americarecognizes only about twenty species in Vernonia sensu stricto, seventeen of which are in North America north of Mexico, with the others being found in South America.

Kindom:-Plantae

Clade:-Trycheophytes

Clade:-Angiosperms

Clade:-Eudicots

Clade:-Asterids

Order:-Asterales

Family:-Asteraceae

Genus:-Vernonia

- Other flora which we explored are

1. Tinospora cordifolia ,
2. Ageratum ,
3. Cassia tora ,
4. Alternanthera ,
5. Phyllanthus ,

6. Azadirachta ,

7. Tephrosia ,



wild Tulsi , etc . **Tinospora cordifolia**



Shri Shivaji Education Society Amravati's
Science College Congress Nagar, Nagpur
Department of Botany

REPORT

Study Tour 2023-2024

16th October 2023

Field study is essential part of Botany. The natural Environment i.e. the Surrounding where we all interact the plants in their natural Habitat is one of the most interesting things that is needed to be studied by the students.

Educational tour are an excellent way to enhance the learning experience of student these tour provide an opportunity to explore the world outside of the classroom and gain practical knowledge.

As a part of B.Sc. Curriculum, one day trip was organized to Shiv Tekdi Temple it is located 35km North Parseoni Taluka in Nagpur District, Pench Forest, Dam (Navegaon Khairi) and Ghogra Mahadev located in the Parseoni Tehesil of Nagpur District, Maharashtra by Department of Botany, Science College, Congress Nagar Nagpur on 16th October, 2023 for semester I, III and Vth botany students.

Total 3 teaching staff, 3 non teaching staff and 64 students were visited to Shiv Tekdi Temple, Pench forest and Ghogra Mahadev. The major objective was to familiarize the students with the wild and cultivated flora and ecology of the region.

During excursion we found Forest rich in diversity. The student collected the different plant species during excursion. The diversity of plants with reference to their habitat, morphology , economic use etc.

AIMS AND OBJECTIVES OF THE STUDYTOUR

To observe and collect the plant species.

To study the Natural habitat and characters of the plants found in the area.

To collected plant may be kept and used for reference study.

Shiv Tekdi is small village/hamlet in parseoni Taluka in Nagpur District of Maharashtra State India. It comes under Tekdi Panchayath. It belongs to Nagpur Division. It is Located 35KM towards North from District head quarters Nagpur .831 KM From state capital Mumbai. Tekdi pincode is 441404 and postal head office is Kamthi Colliery. Tekdi

surrounded by Ramtek Taluka towards East saoner Taluka Towards west. Kamptee Taluka towards south,Nagpur Taluka tovars South. Ramtek ,Kamptee ,savner, Nagpur are the nearby cities to Tekdi. Tekdi Local language is Marathi Tekdi village Total Population is 352 and the number of houses are 79. feamles Population is48.3% Village literacy rate is 67.0% and females Literacy rate is 29.8% amdi Railway Station is the very near by railway to Tekdi. Ramtek, Kamthi,Nagpur, Khapa are the nearby towns to tekdi having road connectivity to Tekdi.

- ❖ Locality Name: Tekdi
- ❖ Taluka Name: Parseoni
- ❖ Constituency:Ramtek
- ❖ District: Nagpur
- ❖ State: Maharashtra
- ❖ Region: Vidarbh
- ❖ Division: Nagpur
- ❖ Language: Marathi ,Hindi
- ❖ Date: Monday 16 oct 2023
- ❖ Time Zone: IST(UTC+5:30)
- ❖ Elevation: 310 Meters, above sea level
- ❖ Telephone code/std code: 07102
- ❖ Pincode: 441404
- ❖ Temperature: 29.0 C
- ❖ Humidity: 41%

Kamthikhairy Dam, also called PENCH Dam, is on the [PENCH river](#) near Parshivni in the state of Maharashtra, India. The dam was constructed for irrigation, and supplies water to two districts of Maharashtra, [Nagpur](#) and [Bhandara](#). The dam is located in the West [PENCH National Park](#) Range, surrounded by forested hills, and is 54 km north of Nagpur. Ghogra Mahadev is a popular tourist destination the natural beauty of the place is simply stunning .the rocky formations the flowing river ,and lush vegetation make for truly unforgettable experiences .The rocky formations around the temple resembles a maze which is one of the things that makes the place unique.

Official name	PENCH Project (Kamthikhairy Dam) D01100
Location	Nagpur
Coordinates	21.4608421°N 79.1902631°E
Construction began	1970
Opening date	1976 ^[1]
Owner(s)	Government of

<u>Maharashtra, India</u>	
Dam and spillways	
<u>Type of dam</u>	<u>Earthfill</u>
Impounds	<u>Pench river</u>
Height	32 m (105 ft)
Length	1,876 m (6,155 ft)
Dam volume	4,928 km ³ (1,182 cu mi)
	Reservoir
Total capacity	180,000 km ³ (43,000 cu mi)
Surface area	23,653 km ² (9,132

SOIL TYPES

There are six types of soils found in Nagpur district i.e Kali soils, Morand soils, Khardi soils , Bardi soils, Kachchar soils, Wardi soils

CLIMATE

The climatic conditions of Nagpur are characterized by a tropical climate. In winter, there is much less rainfall than in summer. The temperature here averages 27.0°C | 80.7 °F. Annually, approximately 1128 mm | 44.4 inch of precipitation descends. Nagpur experiences a moderate climate, and the summers are not easy to define. The best time to visit is February, March, September, October, and November. In terms of precipitation, the month with the lowest amount of rainfall is December, recording a mere 6 mm| 0.2 inch in its entirety. This denotes an exceptionally dry period within that particular time frame. Most precipitation falls in July, with an average of 355 mm |inch.The month that experiences the highest temperatures throughout the year is referred to as May, where an average temperature of 35.6 °C | 96.1 °F prevails. In January, the average temperature is 21.1 °C | 69.9 °F. It is the lowest average temperature of the whole year.



Tour Incharge
Dr. Reshma P. Sonwalkar



HOD
Prof. R. N. Deshmukh

Lantana camara



Euphorbia hirta



Sida acuta



Tephrosia purpurea



Ocimum basilicum



Solanum virginianum

Vitex negundo



Jatropha podagrica



Persicaria longiseta



Clerodendrum chinense



Date: 20/09/2023

**Shri Shivaji Education Society Amaravati's
Science College, Congress Nagar, Nagpur**

Notice

All the students of B.Sc Sem - I, III & Vth are hereby informed that, Department of Botany will be organizing Short Excursion tour to visit Shiv Tekdi, Ghogara Mahadev and Pench forest as a part of your curriculum on dated 26/09/2023 to explore the flora in their natural habitat. All information will be provided to the students (respective groups) and they are informed to give their names on or before 22/09/2023 to Dr. Reshma P. Sonwalkar (8007684396).

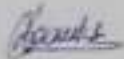

Tour In-charge

Dr. Reshma P. Sonwalkar



Prof. R.N. Deshmukh

Shri Shivaji Science College, Congress Nagar, Nagpur.

Department of Botany

Study Tour

Date: 16/10/2023

Sr.No	Student Name	Mobile No	Sem- I, III, V	Sign	Attendance
1	Poonam Dubey	8459364896	I	<i>Poonam Dubey</i>	P
2	Manisha Dehankar	8788524154	I	<i>Manisha Dehankar</i>	P
3	Sangita Suthar	8412811333	Sem I	<i>Sangita Suthar</i>	P
4	Grishma Ghatule	7385732343	Sem I	<i>Grishma Ghatule</i>	P
5	Gaytri Nagpure	9329948801	sem I	<i>Gaytri Nagpure</i>	P
6	Swasti Giradkar	8552977359	sem-I	<i>Swasti Giradkar</i>	P
7	Mohk Solanki	8411945305	Sem-I	<i>Mohk Solanki</i>	P
8	Tanshree Sorde	7887597689	Sem I	<i>Tanshree Sorde</i>	P
9	Rohan Darode	7704673328	Sem I	<i>Rohan Darode</i>	P
10	Sahil Chauhan	9155173048	sem I	<i>Sahil Chauhan</i>	P
11	Injila Khan	7972709708	I	<i>Injila Khan</i>	P
12	Unnati Atram	7875800112	I st	<i>Unnati Atram</i>	P
13	Soumya Yadav	7559426074	I st	<i>Soumya Yadav</i>	P
14	Tanvi Mandale	9579166655	Sem I	<i>Tanvi Mandale</i>	P
15	Devyani Alone	9834946591	Sem I	<i>Devyani Alone</i>	P
16	Dipesh Yadav	9168426808	Sem I	<i>Dipesh Yadav</i>	P
17	Deepak Baghel			<i>Deepak Baghel</i>	P
18	Tanushree Jadhav	7620182447	Sem I	<i>Tanushree Jadhav</i>	P
19	Janhavi Humne	9552046665	sem I	<i>Janhavi Humne</i>	P
20	Shrushti Yakar	8999654235	sem I	<i>Shrushti Yakar</i>	P
21	Vanshika Paware	9276989688	SEM I	<i>Vanshika Paware</i>	P
22	Sanika Raut			<i>Sanika Raut</i>	A
23	Aditi Rathod	9403041184	Sem I	<i>Aditi Rathod</i>	P
24	Natasha Pidurkar	9922136943	Sem I	<i>Natasha Pidurkar</i>	P
25	Madhavi Gurnule	7774885691	Sem I	<i>Madhavi Gurnule</i>	P
26	Kumudini Bawane	9356770242	Sem I	<i>Kumudini Bawane</i>	P
27	Mansi Deogadkar			<i>Mansi Deogadkar</i>	A
28	Ekta Tambuskar	89999608587	sem-I	<i>Ekta Tambuskar</i>	P
29	Namita Verma	9699709769	Sem I	<i>Namita Verma</i>	P
30	Mansi Nakhale			<i>Mansi Nakhale</i>	P
31	Gaytri Hedau	8421229560	Sem I	<i>Gaytri Hedau</i>	P
32	Pradnya Wasnik	8237978423	sem I	<i>Pradnya Wasnik</i>	P

33	Madhura Rajput	738701791	Sem I	Madhura	P
34	Sayali Kamble	8928614201	Sem III	Sayali	P
35	Yash Doric				P
36	Sanjay Satpute				P
37	Durga Walde	8466950322	Sem I	Durga	P
38	Juhi Uparkar	9764219620	Sem III	Juhi	P
39	Devyani Walke	8263512082	Sem III	Devyani	P
40	Dakshina Madan	7028041891	Sem III rd	Dakshina	P
41	Anuradha Bhagat	9091490377	Sem III	Anuradha	P
42	Minal Besan	9356543795	Sem III	Minal	P
43	Avanti Zadgaonkar	8308787874	Sem III	Avanti	P
44	Yashashri Ghaywat	8767884027	Sem III	Yashashri	P
45	Manjari Dhole	8624996148	Sem III	Manjari	P
46	Ekta Kasekar	8625933724	Sem III	Ekta	P
47	Payal Chatap	9021528174	Sem III	Payal	P
48	Suhani Fulzele	7828290641	Sem III	Suhani	P
49	Samita Samrit	806550702	Sem III	Samita	P
50	Vidya Uikey	9307709765	Sem - III	Vidya	P
51	Gayatri Uikey	8010956309	Sem - III	Gayatri	P
52	Vedanti Fiske	9359091633	Sem - I	Vedanti	P
53	Kaynat Patei	9022794953	Sem I	Kaynat	P
54	Mrunmayee Sathawane	8999033129	Sem - III	Mrunmayee	P
55	Sneha Bongade	8010515429	Sem III	Sneha	P
56	Shrushti Raut	8637719336	Sem III	Shrushti	P
57	Riya Singh	8724978863	Sem I	Riya	P
58	Mansi Nakhale	7972747992	Sem I st	Mansi	P
59	Prashik Dhabarde				P
60	Gairina Chadokar	8604498505	Sem III	Gairina	P
61	Gayatri Bhise	7109004213	Sem I	Gayatri	P
62	Saloni Selote	86199653465	Sem I	Saloni	P
63	Shreya Kalambe	8208804360	Sem - III	Shreya	P
64	Shreelika Desai	9561853197	Sem - III	Shreelika	P
65					
66					
67					
68					
69					

Reshma

Tour Incharge
Dr. Reshma P.Sonwalkar

Bany

HOD
Prof. R.N. Deshmukh

Project Report on
On Job Training (OJT)
Comprehensive Guide to PCB Design & Fabrication
V S Informatics, Nagpur

As per the provisions of

National Education Policy 2020



Submitted to

RTM Nagpur University, Nagpur

Towards partial fulfillment of M.Sc. Physics Semester II

S/2024 Examination (Course Code MOJ2P01, Credit 4)



By

Joy George Panakal

Department of Physics

SHRI SHIVAJI EDUCATION SOCIETY AMRAVATI'S

SCIENCE COLLEGE

Congress Nagar, Nagpur

2023-2024

**Project Report on
On Job Training (OJT)
Comprehensive Guide to PCB Design & Fabrication**

Submitted to



RTM Nagpur University, Nagpur

Towards partial fulfillment of M.Sc. Physics Semester II

S/2024 Examination (Course Code MOJ2P01, Credit 4)

Joy.G.Panakal

Student M.Sc. Semester-II

Mr.Sandeep.Sonaskar

Mentor (V S Informatics)



Dr.(Mrs).R.N.Pathare

Supervisor &

Assistant Professor

Prof.S.W.Anwane

Professor & Head

Department of Physics
SHRI SHIVAJI EDUCATION SOCIETY AMRAVATI'S
SCIENCE COLLEGE
Congress Nagar, Nagpur



Certificate of OJT

This certificate goes to

Joy Panakal

in appreciation of your successful completion of On Job Training on "PCB
Design & Fabrication" from 15 Feb 2024 to 05 March 2024



Sandeep Sonaskar

Director



Acknowledgement

First, I would like to thank **Mr. Sandeep Sonaskar** the Director(Mentor) of **VS Informatics** for giving me the opportunity to do an internship within the organization.

I also would like all the people that worked along with me **VS Informatics** with their patience and openness they created an enjoyable working environment.

It is indeed with a great sense of pleasure and immense sense of gratitude that I acknowledge the help of these individuals.

I am highly indebted to Principal **Dr.M.P. Dhore**, for the facilities provided to accomplish this internship.

I would like to thank my Head of the Department **Mr. S.W. Anwane** for his constructive criticism throughout my internship.

I would like to thank **Dr.Ragini.N. Pathre**, College Internship coordinator and **Physics** Department internship coordinator for their support and advices to get and complete internship in above said organization.I am extremely grateful to my department staff members and friends who helped me in successful completion of this internship.

Mr. Joy George Panakal

VS Informatics

VS Informatics Pvt Ltd Established in 2010 under Govt Company Act 1959(CIN:U72900MH2010PTC205754) works in Cloud server hosting, Call center dialer,

Asterisk based communications, Research & Development in Iot & IIot. With vision to Provide technology solutions for customers with reliable, affordable and quality service.

Introduction to PCB

Printed Circuit Boards can be defined as rugged nonconductive board on substrate-based structure. The PCB's are mainly used to provide electrical connection and mechanical support to the electrical components of a circuit. Printed circuit boards (PCBs) are a massive part of just about every piece of electronic equipment that we have in our everyday lives. The computer you use, the phone in your pocket, your television, and so much more rely on these boards.

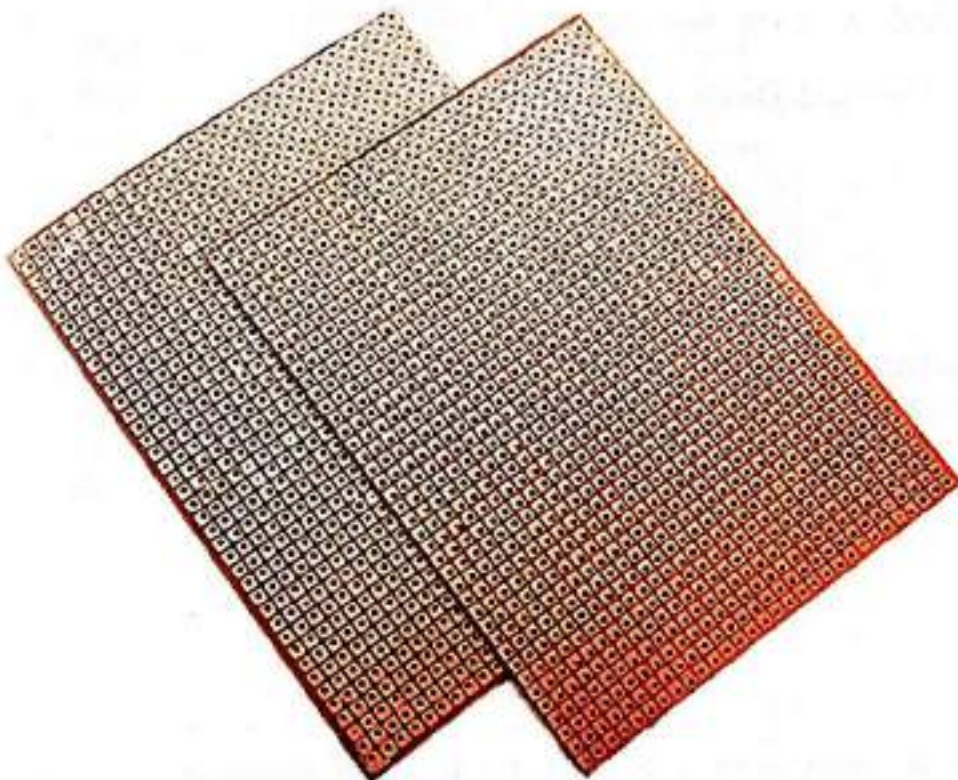

Types of PCB

- Single Layer PCB
- Double layer PCB
- Multi-Layer PCB

1. Single layer printed circuit boards are among some of the simplest to design and manufacture.

These boards have a single layer of conductive material (such as copper) on only one side of a non-conductive substrate.



2. Double layer PCBs have one conductive layer on top of a non-conductive substrate and another conductive layer on the reverse side (top and bottom layers).

The two conductive sides can be connected using plated holes in the substrate that connect to pads on both sides of the circuit board; these are called vias.

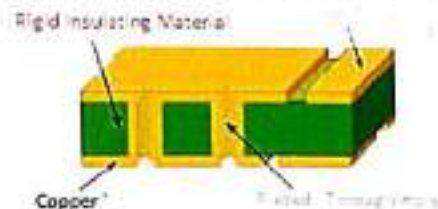

3. This term refers to a circuit board that has three or more conductive layers. The conductive layers are at the top and bottom, as well as at least one conductive layer sandwiched between non-conductive substrate.



Advantages of PCB

- A printed circuit board can contain a number of parts and elements. Because they utilize copper tracks rather than actual wires, it allows for the same types of results without using current-carrying wires. The boards are smaller and they are not as bulky. This is one of the reasons that so many different types of electronic devices are smaller than they were in the past.
- One of the best benefits of using printed circuit boards is the amount of time that can be saved. Connecting components traditionally takes a lot of time, whereas the circuit board will take far less time to assemble once the design is complete. The design phase is often what takes the most amount of time with printed circuit boards, but even this can be reduced when using the right type of software for its creation.
- The connections in the printed circuit board are made through the copy tracks, and as long as they have been manufactured properly, you are not going to have to deal with short circuits or loose connections. Compare this to other methods using actual wires, which could become loose when the board moved. In some cases, the wire itself might have a connection problem

Methods of making PCB

1. **Designing the Circuit:** The first step in making a PCB is to design the circuit schematic using a software tool like EasyEda.
2. **Creating the PCB Layout:** Once the circuit schematic is designed, the next step is to create the PCB layout. This involves arranging the components on the board and tracing the connections between them.
3. **Printing the Design:** The PCB layout is then printed onto a special type of paper known as a "photographic film" or "transparency film" using a laser printer or a photocopier.
4. **Transferring the Design onto the Copper Board:** The printed design is then transferred onto a copper-clad board using a heat press or iron. The toner from the printed design acts as a resist, protecting the copper beneath it.
5. **Etching the Board:** The next step is to etch the board using a chemical solution such as ferric chloride. The etchant removes the exposed copper, leaving only the circuit traces behind.
6. **Cleaning and Inspecting:** Once the etching is complete, the board is cleaned thoroughly to remove any remaining toner or etching residue. The board is then inspected to ensure that the traces are clean and free of defects.
7. **Drilling Holes:** Holes are drilled into the PCB to accommodate the components that will be soldered onto it. This can be done using a drill press or a CNC machine.
8. **Soldering Components:** Once the holes are drilled, the components are soldered onto the PCB. Solder is used to create electrical connections between the components and the trace lines on the board.

9. Testing the PCB: After soldering the components, the PCB is tested to ensure that the circuit functions as intended. This can be done using a multimeter or a dedicated PCB tester.

10. Finishing the PCB: Finally, the PCB is cleaned again to remove any flux or solder residue. It can then be coated with a protective layer such as solder mask or conformal coating to prevent corrosion and improve durability.

PCB Designing:

Following are the steps for PCB designing.

- Components of PCB
- Composition of PCB
- PCB Characteristics

1. Major PCB Component Families

- Resistors - An electric circuit element that introduces an electrical friction or resistance in the path of electric current is called a resistor. The characteristic by which it opposes the flow of current is known as resistance.
- Capacitors - An electric circuit element that has an ability of storing electrical energy in the form of electric field is called a capacitor. The property of the capacitor by virtue of which it stores electrical energy is known as capacitance.
- Inductors - Inductor is basically a wire of finite length twisted into a coil. An inductor is also a basic circuit element that is used to introduce inductance in an

electrical or electronic circuit. The inductor has a property, known as inductance, which oppose any change in the electric current.

- Bipolar junction transistor (BJT) - A BJT is constructed as two diodes sharing a common semiconductor junction, i.e., a p-n-p or n-p-n design. These three doped semiconductor regions correspond to the three terminals of the BJT: the base, collector, and emitter.
- Field effect transistor (FET) - Like the BJT, the FET contains three terminals – the source, gate, and drain – which are analogous to the emitter, base, and collector. In contrast, FETs conduct with only one charge carrier (electron or electron-hole) instead of the mix of electrons and electron holes in BJTs.

2. Composition of PCB

PCBs are a group of man-made organic chemicals consisting of carbon, hydrogen and chlorine atoms. The number of chlorine atoms and their location in a PCB molecule determine many of its physical and chemical properties. PCBs have no known taste or smell, and range in consistency from an oil to a waxy solid.

3. Materials of PCB

PCB generally consists of four layers, which are heat laminated together into a single layer. The different types of PCB materials used in PCB from top to bottom includes.

- Silk screen
- Solder mask
- Copper Foil
- Substrate/Core

About EasyEDA

EasyEDA is an easier and powerful online PCB design tool that allows electronics engineers, educators, students, makers, and enthusiasts to design and share their projects. This is a design tool integrate LCSC components catalog and JLCPCB PCB service that helps users to save time to make their ideas into real products.



Making of Schematic Design

1. Define Requirements:

- Before starting the schematic design, it's important to clearly define the requirements of the PCB in terms of functionality, components, interfaces, and any specific constraints.

2. Select Components:

- Choose the components that will be used in the design, ensuring they meet the required specifications and standards. Consider factors such as size, power requirements, signal compatibility, and availability.

3. Create Schematic Symbols:

- Develop or use schematic symbols for each component in the design. These symbols represent the electrical connections and functions of the components on the schematic diagram.

4. Connect Components:

- Connect the components in the schematic using lines and wires to represent the electrical connections between them. Pay close attention to signal flows, power distribution, and grounding schemes.

5. Organize and Label:

- Organize the components and wires in a clear and logical manner to enhance readability. Label signals, power supplies, and important nodes to ensure clarity and ease of understanding.

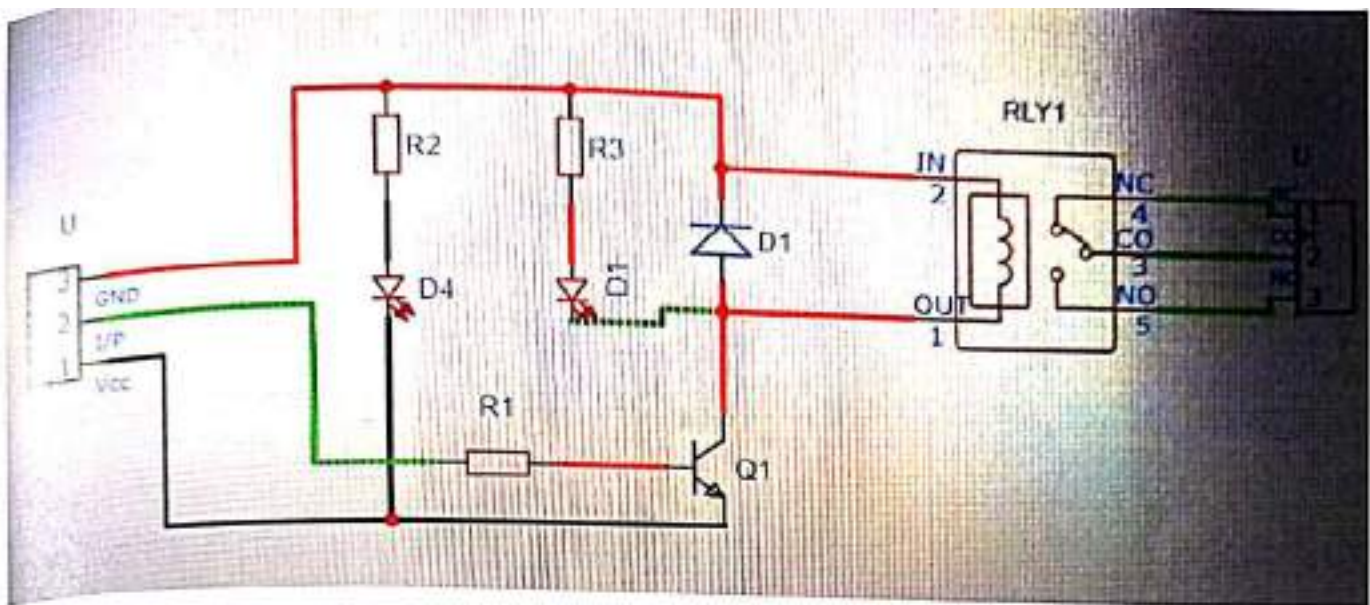

Netlist Generation

- A netlist is a list of all the electrical connections between components in a PCB design. It serves as a critical bridge between the schematic and layout stages of the design process. Here's how netlist generation typically works
- From Schematic to Netlist: PCB design software tools allow designers to generate a netlist from the schematic design. This process captures all the connections between components, including signal names, component designations, and pin numbers.

Bill of Materials (BOM) Generation

- A Bill of Materials (BOM) is a comprehensive list of components and materials required to build a PCB. It includes information such as part numbers, descriptions, quantities, and sometimes pricing information. Here's how BOM generation typically works
- Component Information: The BOM starts with a list of components used in the design, including active components (ICs, transistors) and passive components (resistors, capacitors).
- Supplier Part Numbers: For each component, the BOM may include supplier part numbers to facilitate sourcing and procurement processes.
- Quantities: The BOM specifies the quantities of each component required for the PCB assembly. This information is crucial for manufacturing and inventory management.

ID	A	B	C	D	E	F	G	H	I	J
	Name	Designator	Footprint	Quantity	Manufact	Manufact	Supplier	Supplier Pz	Price	
1	DIODE	D1	DIODE1N4	1						
2	S LED10	D1	LED-TH_LE	1						
3	P LED10	D4	LED-TH_LE	1	5600	VccLite	Digi-Key	L20325-ND		
4	Transistor	Q1	TRANSISTC	1	5600	VccLite	Digi-Key	L20325-ND		
5	10KΩ	R1,R2,R3	SMD-RESIS	3	TC0325B1	UniOhm	LCSC	C39049	0.074	
6	5 V SPDT	RLY1	RELAY-TH_	1	SRD-05VD	松乐	LCSC	C35449	0.333	
7	3 Pin 2.54	U,U	CONNECTI	2	Female he	BOOMELE	LCSC	C27438	0.074	

Footprint Description

- Position of pads or holes. This information indicates where the pads for the assembly of SMD components, or the holes for fixing the through-hole components, are located. This information is essential for the soldering process and must be precisely defined.
- Outline, or courtyard, of the component. It can be defined as an area, or perimeter, of protection for the PCB footprint. This prevents other components from being placed within this area. This boundary delimits the entire body of the component and is the primary layer responsible for defining the shape of the component.
- Reference designator. It is an alphanumeric code that uniquely identifies the component within the schematic and PCB layout. In Figure 2 some reference designators are highlighted, such as the R75 resistor and the LD3 LED.
- Pin 1 designator. When placing components with a large number of pins, such as integrated circuits, it is important to indicate the position of pin 1 on the footprint, in order to avoid possible misunderstandings during the assembly phase. This is the case, for example, of components which have QFP or DIP packages. In the example of Figure 1, the reference to pin 1 is represented by a circle.
- Mechanical information. Some components may have some mechanical part, or a protrusion that may extend over other components, creating possible collisions or overlaps between components. This occurs, for example, with heat sinks.
- 3D model and symbols. Each PCB footprint has an associated symbol in the schematic and, in most cases, also has an associated 3D model. This allows the designer to create a 3D model of the entire board, verifying the correct

positioning and mutual distances between the components.

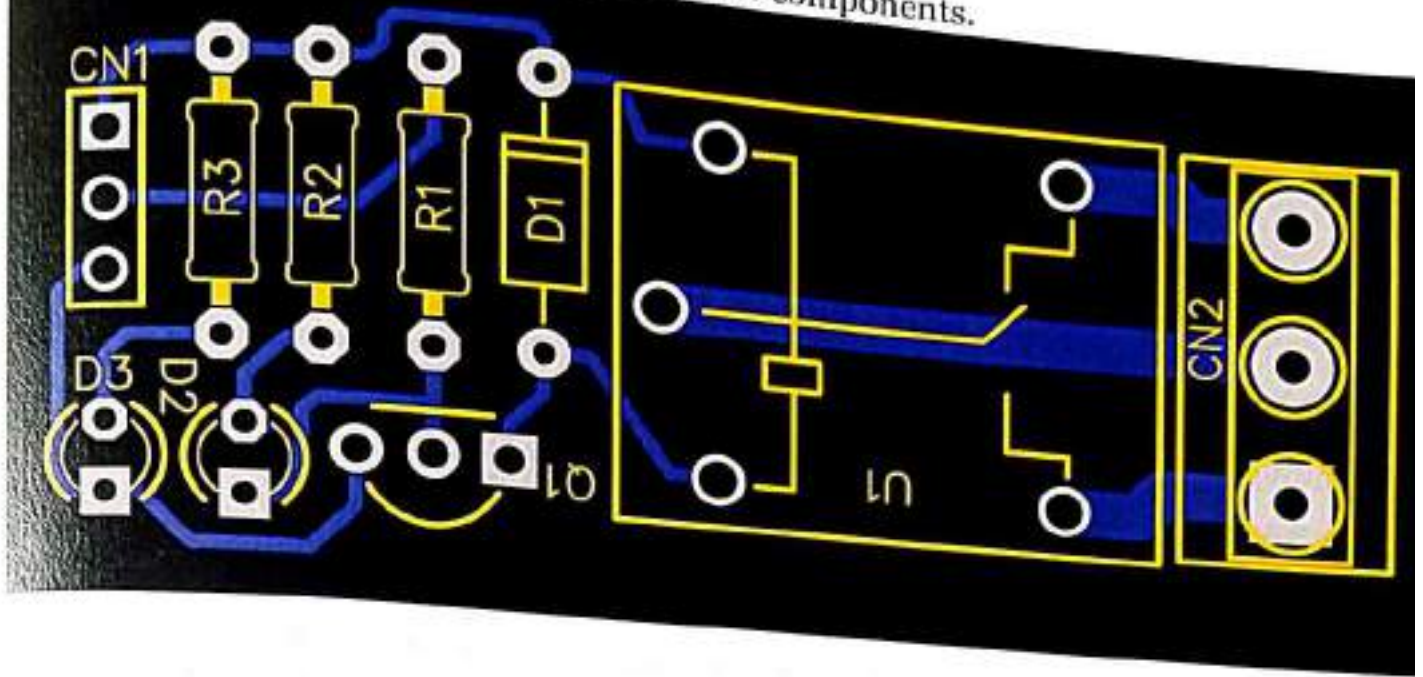

Selecting and assigning footprint

1. **Component Selection:** Ensure you have a detailed component list, including part numbers, manufacturer names, and package types. This information will help you find the appropriate footprints.
2. **Footprint Library:** Use a footprint library that contains a wide variety of standard footprints for different components. You can also create custom footprints if necessary.
3. **Identify Footprints:** Match each component in your list with the corresponding footprint in the library. Make sure the footprint matches the package type and dimensions of the component.
4. **Check Manufacturer Datasheets:** Refer to the manufacturer datasheets for each component to verify the recommended footprint. Datasheets often provide detailed information on the footprint dimensions and pad layouts.

Designing tracks in PCB

- **Track Width:** The track width determines the amount of current the track can carry without overheating. The track width should be chosen according to the current-carrying capacity required to prevent overheating and damage to the PCB. The wider the track, the higher the current it can carry.
- **Track Spacing:** The spacing between tracks should be sufficient to prevent electrical crosstalk or interference. The spacing should meet the minimum requirements to avoid short circuits or signal integrity issues.
- **Routing:** The routing of tracks should be done carefully to avoid signal interference and maintain signal integrity. Proper signal paths should be followed, and signal lines should be kept as short as possible to reduce signal degradation.

PCB Edges

- **Edge Clearance:** Ensure that there is sufficient clearance between the edge of the board and any components or tracks to prevent electrical shorts or interference. The clearance should meet the minimum requirements specified by the manufacturer and industry standards.
- **Edge Plating:** Edge plating is the process of plating the edges of the PCB with copper to provide additional mechanical strength and protection. Edge plating can also help improve EMI shielding and grounding.

3D View of Gerber File Generation

- Gerber files are a standard file format used in PCB fabrication. They contain information about the PCB layout, such as copper traces, pads, holes, and markings.
- Generating a 3D view of a PCB from Gerber files involves converting the 2D information into a 3D model that can be visualized in three dimensions.



Component Creation

- When designing a PCB, creating accurate and detailed components is crucial for the success of the project. Components are the individual parts that make up the electronic circuit and include devices such as resistors, capacitors, integrated circuits, connectors, etc.
- Components need to be created with specific attributes such as footprint, pin configuration, designators, and 3D models for accurate placement on the PCB.

Adding Component to Library

- To add a component to a library in a PCB design software, you typically follow these steps:
- Create a New Library: Start by creating a new library within the PCB design software where you want to store the component.
- Add Component: Add a new component to the library by specifying its properties such as name, value, description, and any other relevant information.

Footprint Creation for PCB

- Creating a footprint for a component involves designing the physical layout of the component as it will be placed on the PCB. Here are the general steps involved
- Refer to Component Datasheet: Start by referring to the component datasheet for accurate dimensions, pad layout, and recommended footprint details.

Etching Process

PCB etching is the process of removing unwanted copper from a printed circuit board. Once all of the excess copper has been removed from the PCB, only the required circuit remains.

Before the etching process begins, a layout for the board is generated. This desired layout for the board is transferred onto a PCB by a process called photolithography. This forms the blueprint that decides which pieces of copper must be removed from the board.

On the outer layer of the PCB, the tin plating acts as the etch resist. However, in the inner layer, the photoresist is the etch resist. Generally speaking, there are two approaches to inner layer and outer layer PCB etching. These are dry etching and wet etching. Here at ABL Circuits, we use a wet etching process using a Tech Win Alkali Etching Machine.

Drilling

PCB drilling (which is also known as printed circuit board drilling), is the process of creating holes, slots and other cavities in an electronic circuit board.

During the PCB drilling process, a number of different hole types are drilled. These include via holes (such as thru-holes, buried holes, blind holes and micro-holes), component holes and mechanical holes.

Due to the precision required, holes are usually carved out using a manual or laser PCB drill. Boards can also be fed into a drilling rig manually or automatically. Here at ABL Circuits, our drill has a laser-detect function. This ensures both concentricity and correct bit diameter (0.1mm-6.5mm), even when unmanned.

Soldering

PCB soldering refers to the process of using solder to join two small pieces together onto the surface of an electrical circuit board. The process involves dissolving a solder and running it on the two contacts you wish to bond together.

This technique is a relatively simple and effective way of connecting two or more electrical components on a circuit board.

Soldering Techniques

The soldering techniques can be divided into 2 categories:

- Soft soldering
- Hard soldering

Soft soldering

Soft soldering is a common process for electronics, as well as plumbing. This soldering method is usually used to create electrical connections and adhere electronic components to PCBs. However, the strength of the bonding created by this technique is not as high as hard soldering.

A eutectic tin/lead alloy is used to soft solder metals together. The heat source is usually an electric or gas-powered soldering iron.

Soft soldering is most commonly used to connect connectors to cables, place jumper wires on parts or printed circuit boards, solder wires from transformer coils, and make repairs.

Hard soldering

Hard soldering or silver soldering bonds 2 pieces of metals (i.e. base metals) together, not by melting the solder directly, but by heating the base metals to a temperature that the solder holding the metals together instantly melts. When cooled, an immensely tight joint is formed – through “capillary effect”. Temperature required to melt the solder material, usually silver or brass, is higher than soft solder and requires a blowtorch. This method is used for joining pieces of brass, copper, silver, or gold. Brazing is a form of hard soldering.

Practical

- Schematic Design:-

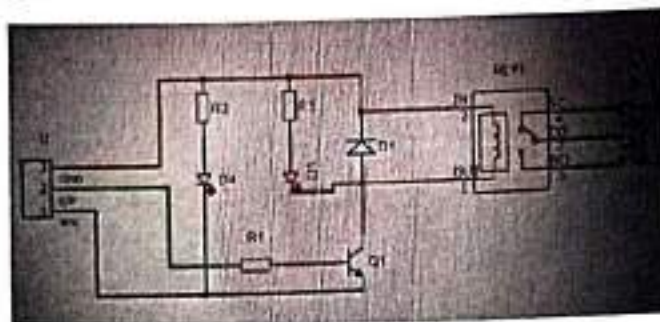

• Footprint:-

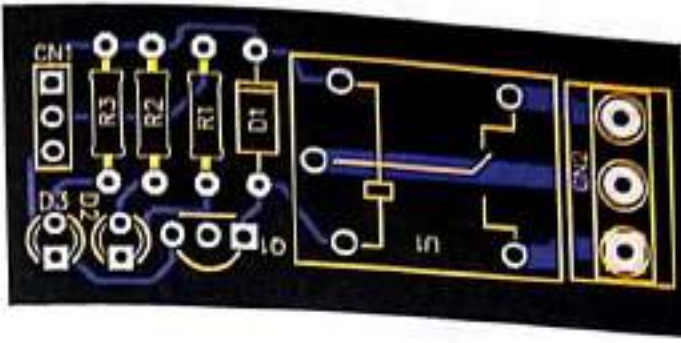

• 3D View:-



• PCA:-

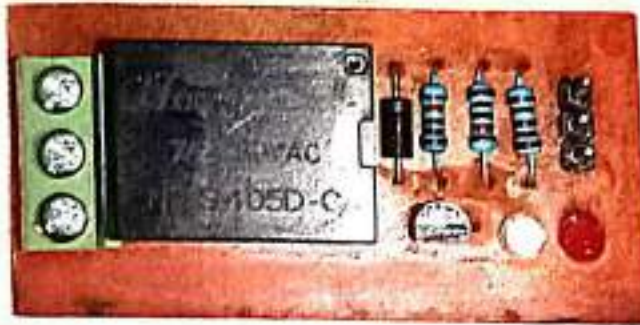

Assignment

LED Dimmer Circuit Diagram:-

LED Dimmer Circuit

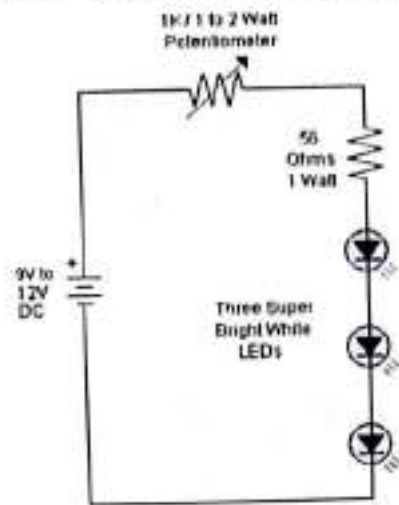

Schematic Circuit of LED Dimmer Circuit:-

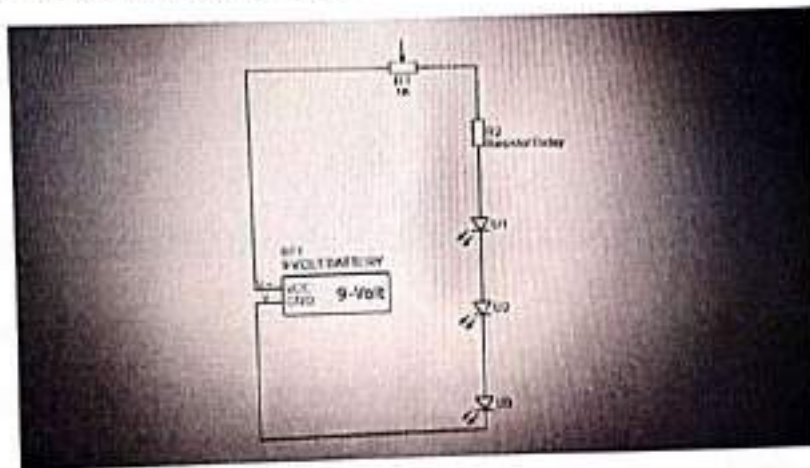

Bill of Materials:-

ID	Name	Designator	Footprint	Quantity	Manufact	Manufact	Supplier	Part No	
1	9 VOLT BATTERY	B1	9V BATTERY	1	No. 7	ReliaPro	LCSC	C9001	
2	1K Resistor	R1	PCB_MDU	1	R-0904N-1	Hittite		R-0904N-1-100	
3	Potentiometer	R2	603	1	PTFR0603I	Resistor	To LCSC	C231646	
4	3x Super Bright White LEDs	U1,U2,U3	LED-SMD	3	108	DEL552	OSRAM	LCSC	C2806682

Circuit Explanation Relay SPDT 5V

Introduction:-

The Single Channel Relay Module is a convenient board which can be used to control high voltage, high current load such as motor, solenoid valves, lamps and AC load. It is designed to interface with microcontroller such as Arduino, NodeMCU, etc. The relay's terminal (COM, NO and NC) is being brought out with screw terminal. It also comes with a LED to indicate the status of relay.

Circuit Diagram:-

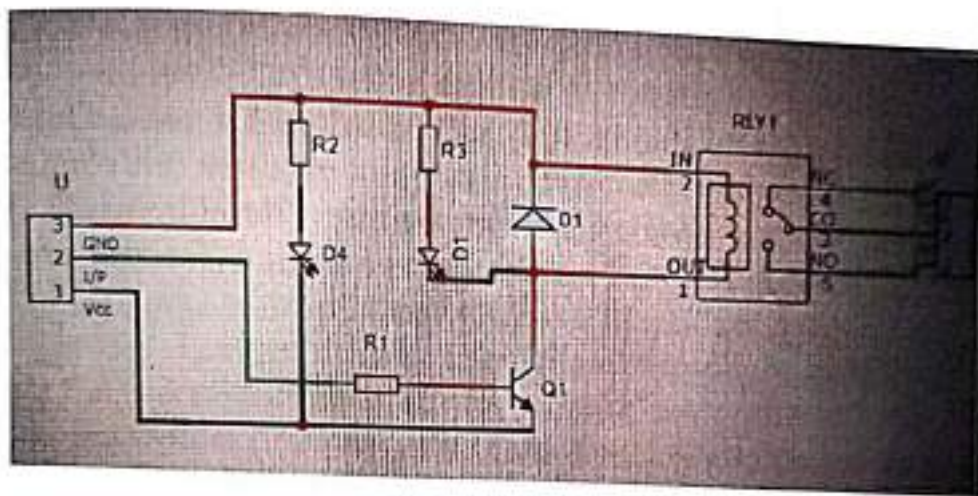

Components Description:-

- **Relay SPDT 5V**-The relay module with a single channel board is used to manage high voltage, current loads like solenoid valves, motor, AC load & lamps. This module is mainly designed to interface through different microcontrollers like PIC, Arduino, etc.
- **Diode 1N4007 PnN Junction**-1N4007 is a PN junction rectifier diode. These types of diodes allow only the flow of electrical current in one direction only. So, it can be used for the conversion of AC power to DC. 1N 4007 is electrically compatible with other rectifier diodes and can be used instead of any of the diode belonging to 1N400X series.
- **Transistor BC547 NPN**-A transistor is basically an electrically controlled switch. There is an input, output, and a control line referred to as the emitter, collector, and base. When the control line (base) is triggered it will connect the emitter and the collector just like switching a switch. Since the power between the emitter and collector can be higher than the base, transistors are often used as amplifiers.
The BC547 is a NPN transistor meaning when power is applied to the base (control pin) it will flow from the collector to the emitter. Typically NPN

transistors are used to “switch ground” on a device, meaning, they are placed after the load in a circuit.

- **Resistor 10k**-A 10k resistor is a fundamental electronic component that plays a vital role in circuits by limiting the flow of electric current. Its resistance value is 10,000 ohms. These resistors are identified by a color code, typically brown-black-orange-gold, where each color represents a digit or multiplier.
- **Led**-A light-emitting diode (LED) is a semiconductor device that emits light when an electric current flows through it. When current passes through an LED, the electrons recombine with holes emitting light in the process.
- **Sip 3 pin 2.54mm**-This specification covers the requirements for application of SIP (Single In-Line Package) Sockets with Compliant Pins Contacts on 2.54 mm [.100 in.] centers. The sockets consist of a housing and contacts, and are available in a variety of sizes (ie, contact positions). They are designed to be inserted into printed circuit (pc)boards using manual or robotic equipment.
- **Wire connector 3 Pin 5mm**-The 5mm 3Pin Screw Type PCB Terminal Blocks are a reliable and versatile solution for connecting wires on printed circuit boards. These solderable connectors offer a convenient and secure way to establish electrical connections in various electronic devices and systems. With a pin spacing of 5mm, these terminal blocks are designed to accommodate wires with ease. The generous spacing allows for easy installation and connection, reducing the risk of accidental shorts or faulty connections. Whether you are a seasoned electronics hobbyist or a professional, these connectors will make your PCB assembly process quick and efficient.

Theory of Operation:-

It works on the principle of an electromagnetic attraction. When power flows through the first circuit, it activates the electromagnet, generating a magnetic field that attracts a contact and activates the second circuit. When the power is switched off, a spring pulls the contact back up to its original position, switching the second circuit off again.

Conclusion:-

The following observations can be drawn from the detailed study on PCB, The Printed Circuit Board (PCB) is very important in all electronic gadgets, which are used either for domestic use, or for industrial purpose. PCB design services are used to design the electronic circuits. Apart from electrically connecting, it also gives mechanical support to the electrical components. Thus, an effective PCB design can help in reducing the possibilities of errors and the chances of short circuit. Therefore, learning to design circuit in a PCB has great chances to explore in the field of electronics.

All this valuable experiences and knowledge is that we have gained were not only acquired through the direct involvement in task but also through the other aspect of training such as work observation, interaction with mentors, and others related to the laboratory.

Here I am concluding, this training program has satisfied my primary objectives, and as a result I am more confident practically and theoretically on my respective subjects, which in future will become helpful to build my career.

Shri Shivaji Education Society Amravati's

SCIENCE COLLEGE

Congress Nagar, Nagpur

Department of Physics

OJT 2023-24

Sr No	Name of the Students	Year
1	Joy George Panakal	M Sc II Sem
2	Mahevash Zamani Baig	M Sc II Sem
3	Nakul Avinash Deogade	M Sc II Sem
4	Nisha Yuvraj Shidurkar	M Sc II Sem
5	Ranita Eknath Aglave	M Sc II Sem
6	Sakshi Omprakash Ukey	M Sc II Sem
7	Shraddha Vishwas Raut	M Sc II Sem
8	Prerana Ambade	M Sc IV Sem
9	Yash Chaube	M Sc IV Sem



Dr. S. W. Anwane
Professor and Head
Department of Physics
Shri Shivaji Education Society Amravati's
SCIENCE COLLEGE
Congress Nagar Nagpur

Shri Shivaji Education Society Amaravati's

Science College

Congress Nagar, Nagpur – 440012



DEPARTMENT OF CHEMISTRY

A Report on

“DEMONSTRATION OF INSTRUMENTATION”

As a part of On Job Training

Submitted By

GAURI PRADIP NASARE

(MSc Semester-II)

2023-24

 20/06/24



धातुकी एवं पदार्थ अभियांत्रिकी विभाग

विश्वेश्वरय्या राष्ट्रीय प्रौद्योगिकी संस्थान
नागपुर - ४४० ०१० (भारत)

Department of Metallurgical & Materials Engineering

Visvesvaraya National Institute of Technology
Nagpur - 440 010 (India)

VNIT NAGPUR

PNX +91(0712) 2227828, 2223710
2221635, 2236330
2224123, 2226750
2236331, 2236332

FAX +91(0712) 2223230, 2223969
HoD (MME) +91(0712) 2801324
MME Office +91(0712) 2801284
Email head@mme.vnit.ac.in

CERTIFICATE

This is to certify that... **KU. Gauri Pradip Nasare**has worked as on-job trainee entitled "**Demonstration of Instrumentation**", in Visvesvaraya National Institute of Technology, Nagpur under the supervision of Prof. Dilip Peshwe from 18th to 30th March 2024. He/She worked for not less than 120 hours during this tenure.



Course Co-ordinator & HOD

Professor & Head
Department of Metallurgical Engineering
Visvesvaraya National Institute of Technology
NAGPUR-440 010

CERTIFICATE

This is to certify that report on "**Demonstration of Instrumentation**" Submitted by **ku.Gauri Pradip Nasare** as a part of on-job training in partial fulfilment of the requirement of the degree of Master of Science in Chemistry, **S.S.E.S Amt's Science College, RTM Nagpur University, Nagpur**. This work was carried out manner in excellent manner by **ku.Gauri Pradip Nasare** under the supervision of Assistant professor of Science College, Nagpur. during the academic year 2023-2024.

Date:- 15/05/2024

Place:- Nagpur

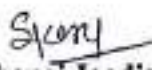
Dr. Mrs. Shubhangi Jagdish Kene
Internal Mentor
Department of chemistry,
S.S.E.S Amt's science College, Nagpur.

CERTIFICATE

This is to certify that **ku.Gauri Pradip Nasare** has carried out the training program / Internship in accordance with the Guidelines of M.Sc. curriculum of RTM Nagpur University for 120 hrs. The student is eligible for examination for 4 credit courses on on-job training/Internship.

Date:- 15/5/2024

Place:- Nagpur

Professor & Head
Department of Chemistry,
Shri Sirya Science College
Congress Nagar, Nagpur
Dr. R.U. Khope

Head & Professor

**Department of chemistry,
S.S.E.S Amt's science College,
Nagpur.**

DECLARATION

I, hereby declare that the work presented in the internship report has been submitted in the partial fulfilment for the degree of Master of Science in Chemistry (M.Sc. Sem-II), Department of Chemistry, S.S.E.S Am't's Science Collage, RTM Nagpur University, Nagpur and has not been submitted for any other degree or diploma.

Date:- 15 May 2024

Place:- Nagpur

GAURI P. NASARE

ACKNOWLEDGEMENT

I am thankful to our Principal **Dr. M. P. Dhore** for allowing us to join VNIT to understand the uses of different state of arts instrument handling technique as a part of on-job training. I would also like to thank **Dr. R. U. Khope**, Head of Department of chemistry, S.S.E.S Amt's science College, Nagpur, for their encouragement and insightful suggestions. I would also like to thank **Dr. Dilip Peshwe, Department of Chemistry and Other Teaching Staff of VNIT, Nagpur** for constant encouragement and guiding me throughout the project work. I would like to express my sincere obligation to my guide **Dr. Mrs. Shubhangi. J. Kene**, Co-Ordinator P.G. Department of Chemistry, for suggesting the Topic and guiding me throughout the project work. I would like to express my sincere obligation to my guide **Dr. Sneha Dandekar**, Department of Chemistry, for their invaluable guidance and support throughout. My earnest thanks to my friends, teaching and non-teaching staff of MSc. Department Of Chemistry. I am very much obliged to active suggestion and prepare inspiration to do this project work. I am grateful to my friends who supported me during the monitoring work, analytical work and data compilation for the project. It gives me immense pleasure to acknowledge all the staffs of the department for their constant guidance, kind-cooperation and valuable suggestions to complete and compile this work.

GAURI P. NASARE

CONTENT

Sr. No.	Particulars	Page No
1	Fourier Transform InfraRed Spectroscopy	2-5
2	Thermogravimetry Differential Thermal Analysis	6-8
3	Muffle furnace Heat Treatment	9-12
4	Scanning Electron Microscope	13-16
5	Field Emission Scanning Electron Microscope	17-20
6	X-Ray Diffraction	21-24
7	Small punch Creep Testing Machine	25-27
8	Atomic absorption spectroscopy	28-31
9	Raman Spectroscopy	32-34
10	Conventional Creep Testing Machine	35-37

Fourier Transform InfraRed Spectrometer

Name of the Instrument:-Fourier Transform InfraRed Spectrometer

Laboratory:- Thermal Analysis Lab

Date:- 19.03.2024

Time:- 11:30 AM

Introduction:-

- i) FT-IR stands for Fourier Transform InfraRed, the preferred method of infrared spectroscopy. In infrared spectroscopy, IR radiation is passed through a sample.
- ii) Some of the infrared radiation is absorbed by the sample and some of it is passed through (transmitted).
- iii) The resulting spectrum represents the molecular absorption and transmission, creating a molecular fingerprint of the sample.
- iv) Like a fingerprint no two unique molecular structures produce the same infrared spectrum. This makes infrared spectroscopy useful for several types of analysis.

Principle :-

- i) Infrared spectroscopy has been a workhorse technique for materials analysis in the laboratory for over seventy years.
- ii) An infrared spectrum represents a fingerprint of a sample with absorption peaks which correspond to the frequencies of vibrations between the bonds of the atoms making up the material.
- iii) Because each different material is a unique combination of atoms, no two compounds produce the exact same infrared spectrum.
- iv) Therefore, infrared spectroscopy can result in a positive identification (qualitative analysis) of every different kind of material.
- v) In addition, the size of the peaks in the spectrum is a direct indication of the amount of material present.
- vi) With modern software algorithms, infrared is an excellent tool for quantitative analysis.

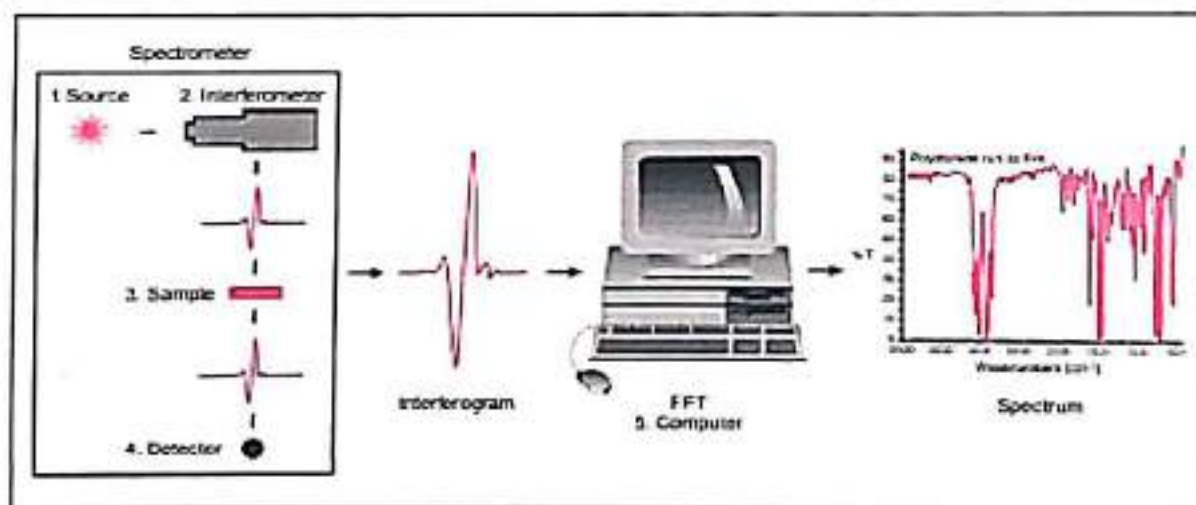

Procedure:-

The normal instrumental process is as follows:

- i) **The Source:** Infrared energy is emitted from a glowing black-body source. This beam passes through an aperture which controls the amount of energy presented to the sample (and, ultimately, to the detector).
- ii) **The Interferometer:** The beam enters the interferometer where the "spectral encoding" takes place. The resulting interferogram signal then exits the interferometer.
- iii) **The Sample:** The beam enters the sample compartment where it is transmitted through or reflected off of the surface of the sample, depending on the type of analysis being accomplished. This is where specific frequencies of energy, which are uniquely characteristic of the sample, are absorbed.
- iv) **The Detector:** The beam finally passes to the detector for final measurement. The detectors used are specially designed to measure the special interferogram signal.
- v) **The Computer:** The measured signal is digitized and sent to the computer where the Fourier transformation takes place. The final infrared spectrum is then presented to the user for interpretation and any further manipulation.

A Simple Spectrometer Layout

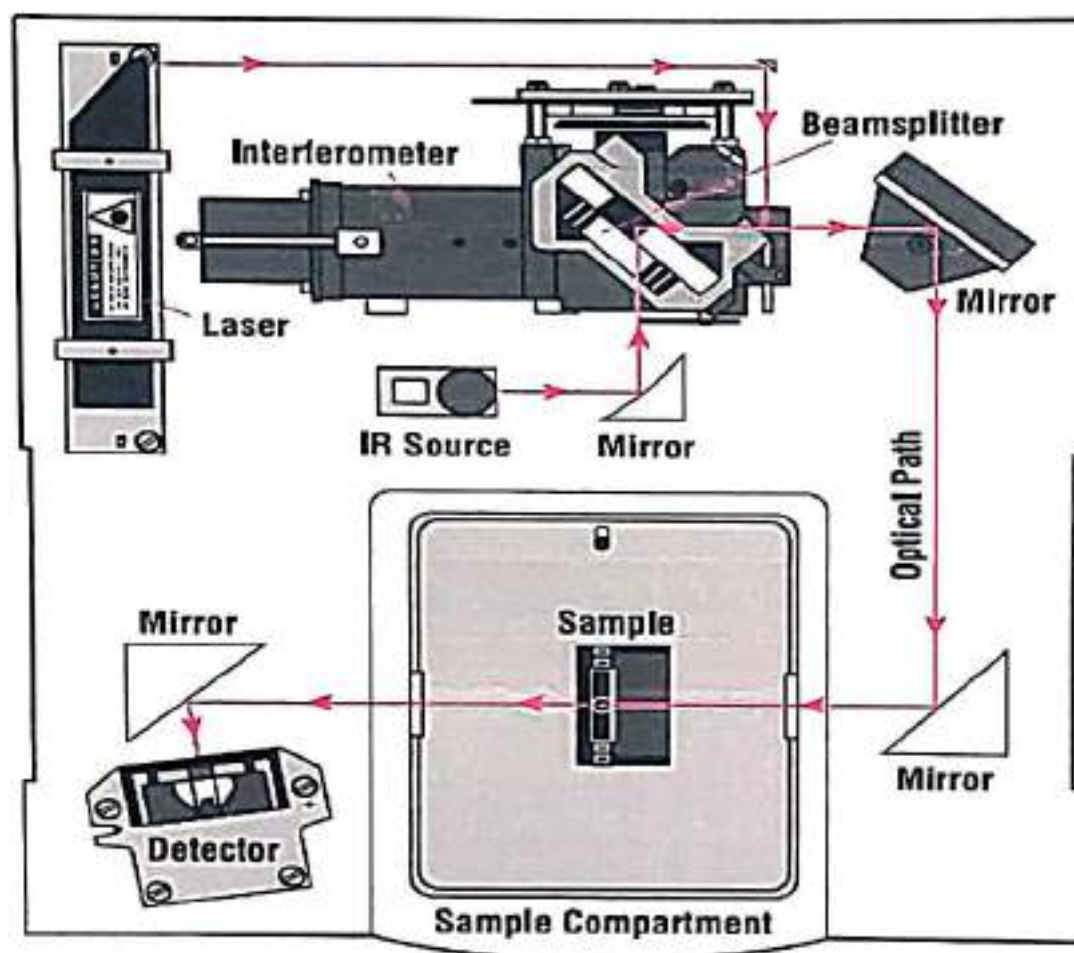

Thermogravimetry Differential Thermal Analysis

Name of the Instrument :- Thermogravimetry Differential Thermal Analysis

Laboratory:- Thermal Analysis Lab

Date:- 19.03.2024

Time:- 12:30 PM

Introduction:-

- i) Thermo-gravity is a branch of thermal analyzer which examine the mass change of a sample as function of temperature (in the Scanning mode) or as a function of time (in the Isothermal mode).
- ii) Thermogravimetric Analysis (TGA) is a forceful technique for the measurement of thermal stability of material including polymers (like thermos-plastic, thermosets, elastomers, composites, plastic films, fibers etc.)

Principle :-

- i) The TG /DTA module uses a horizontal differential System balance mechanism sample weight changes are measured by change in position of slit by optical position sensors.
- ii) The sig to signal from the optical position sensor is sent the balance circuit.
- iii) The balance circuit supplies sufficient feedback current to the driving coil so that the slit return to the balanced position.
- iv) The Current running to the driving coil in the sample slide and the current running to driving coil on the reference side is detected and converted into weight sample.

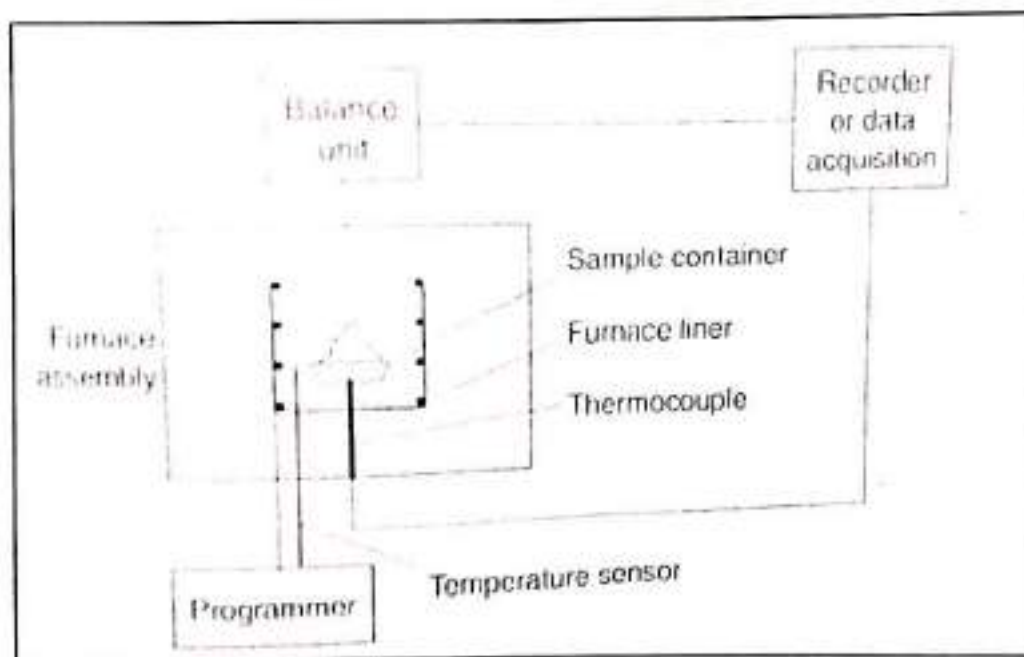

TGA

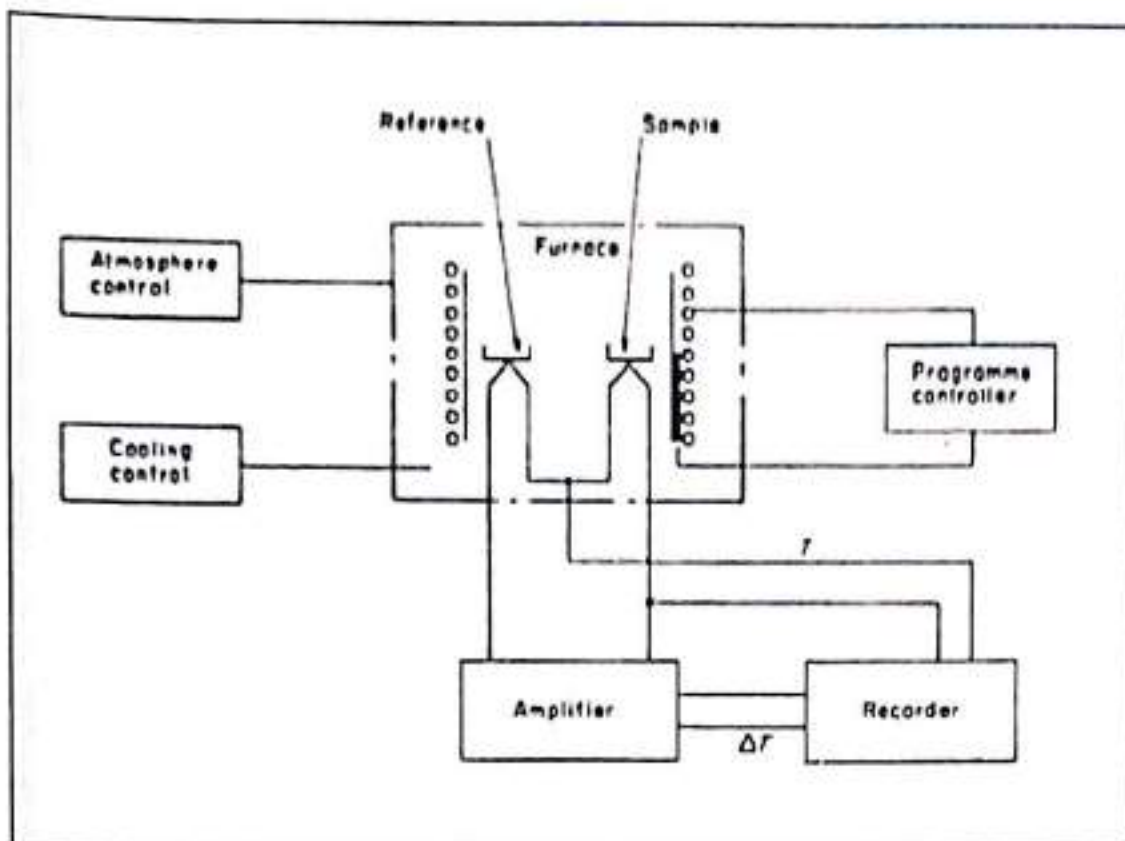

DTA

Procedure:-

Procedure is as followed for TGA

There are two mini size crucibles in furnace, one is reference crucible and another one is Sample crucible. Both the Crucible are made up of platinum (as its melting point is very high) for both the crucible there are two holding pans. Reference crucible is placed on left holding pan and Sample Crucible on right holding pan.

Firstly, for background both the crucible (Reference and Sample) are filled with alumina powder (Melting

Application:-

- i) thermal decomposition of inorganic, organic & polymeric Substance
- ii) Solid-state reaction
- iii) Distillation and evaporation of liquid
- iv) Pyrolysis of coal, petroleum & wood.
- v) Thermal Oxidative deposition of Material
- vi) Reaction Kinetics studies
- vii) Rate of evaporation and sublimation.

Conclusion:-

Thermogravimetry is concerned with the change in weight of material as its temperature changes.

- i) This loss indicated decomposition or evaporation of the Sample.
- ii) The temperature at which no weight loss takes place indicates stability of material.

Conventional Creep Testing Machine

Name of the Instrument :- Conventional Creep Testing Machine

Laboratory:- Creep Testing Lab

Date:- 22.03.2024

Time:- 03:00 PM

Introduction:-

- i) Materials are generally both viscoelastic and extensible. Viscoelastic Materials can be deformed by elongating under the loads they are exposed to the temperature of the material being tested has significant impact on a polymer creep behavior, which deforms at the fastest rate near the glass transition point. Depending on the rate at which its Molecules are distorted a polymer at a given temperature and molecular weight may behave as either liquid or solid. viscoelastic behaviors is the broad term use to describe this phenomenon.
- ii) The amount and duration of elongation of materials under a constant load can be quite interesting the permanent deformation of solid Material by continuous constant Mechanical load is called creep. The material, which is exposed to loads your long time changes in size and shape. The amount of the load, time, temperature, structure, and morphology of the Material all affect, How much the material deform under creep behavior can be roughly. predicted using a power-law Model,

$$\epsilon(L) = M(\sigma, T)t^n$$

Principle :-

- i) According to Hooke's law, the material behaves elastically. According to this principle, the force applied up to the yield strength cause the material to deform in the direction of force and store elastic energy. If the applied force is removed without exceeding the yield strength, the material tends to return to its original shape. However, In the applied force exceeds the yield strength The material exhibits a plastic behavior and begins to breaks.
- ii) An instantaneous deformation is purely elastic response when load is applied following this deformation is primary deformation, characterized by a rapid decrease in low deformation. The next is secondary deformation, a steady state linear deformation, tertiary deformation, which occurs as the sample nears fracture is the acceleration of deformation up to fracture The typical stage of creep deformation.

Procedure:-

- i) The material was tested with the test Machine Based on the dead load principle the load is applied by adjusting the weight or cross section of specimen The stress can be altered. The required temperature can be set in the creep testing machine results from the specimen being clamped with sufficient accuracy.
- ii) **Punch Indenter:**
The punch lip consists of hemi-spherical end with diameter ranging from 2 to 2.5 mm, but on alternative assembly can be used such as flat tip Indenter, and a 2 to 2.5 mm diameter ceramic ball. Ball material include Si_3N_4 . In this instance, the ball should be replaced after every test the geometries of two punch configuration are displaced in Depending on material that is to be tested the punch material can vary from high strength steel for testing. relatively soft and ductile Material such as copper, to high temperature ceramic Materials are to be tested.

iii) Measurement of deformation:

Upon exertion of the testing load, disc deformation is monitored and recorded from two locations by linear variable displacement transducer. One LVDT is usually positioned in a location to detect the movement of load pan and record the displacement on the top surface of disc. The other LVDT is located within the lower die-pull rod assembly and measures the deflection on the underside surface of the specimen by quartz rod. This enables the deformation on both surfaces to be closely monitored. Throughout the test and the resultant SPC curve usually displays an average of the top and bottom recording.

Application:-

- i) It is used to determine how efficient and stable a material is. The machine is used by students and companies to create a creep curve on how much pressure and stress a material can handle. The machine is able to calculate the stress rate, time and pressure.
- ii) Determine a material's expected deformation and avoid failure when designing new systems under different environmental conditions.
- iii) It is used in evaluating materials for boilers, gas turbines, jet engines, ovens or any application that involves high temperature under load.

Conclusion:-

- i) This study presents a low-cost constant load creep test machine for performing creep testing of materials.
- ii) Materials have a very common use area and it is very important to know their mechanical properties. Therefore, a simple low-cost test system was created to examine the constant load creep properties of materials.

Attendance Sheet
Shri Shivaji Science College, Congress Nagar, Nagpur.
M.Sc. Sem II (On Job Training)

Sr. No	Roll	Students Full Name	Days																
			Date	1	2	3	4	5	6	7	8	9	10	11	12	13	14	15	
1	Ku	AAREEN NIGARASIQBAL	18/12/24																
2	Ku	GAURIPRADIPNASARE	19/12/24																
3	Ku	JANIVITUMESHFATING	20/12/24																
4	Ku	KRUSHBUSOMESHWARCHIL	21/12/24																
5	Ku	LAXMI ANIL RAODHOBE	22/12/24																
6	Ku	MAHEK DINESH SHINDE	23/12/24																
7	Ku	MUSKANSATENDRAKUNIBHAW	24/12/24																
8	Ku	NIDHIKADHESHYAMGUPTA	25/12/24																
9	Ku	NIKHITAPANDHARIPIPARE	26/12/24																
10	Ku	PALTAVIPARAMBORRKAR	27/12/24																
11	Ku	PRADNYAARVINDAPTE	28/12/24																
12	Ku	PRANJUASHOKAMBUJE	29/12/24																
13	Ku	ROHITAVISHNUPARDHI	30/12/24																
14	Ku	SEJAL SUBHASH THENGE	31/12/24																
15	Ku	SHABAHATMD. IRFANKHAN	1/1/25																
16	Ku	TANAYAVINAYAKLANJEWAN	2/1/25																
17	Ku	TANNUDINESH SINDURKAR	3/1/25																

**ON JOB TRAINING REPORT
ON
MICROBIOLOGICAL FOOD ANALYSIS
AT
HALDIRAM FOODS INTERNATIONAL, PVT. LTD.
KAPSI, NAGPUR**



**Partial fulfillment of the degree of
MASTER OF SCIENCE
(M.Sc.-I, Semester-II)
IN
MICROBIOLOGY
Submitted by
ANURADHA PURUSHOTTAM KHOPE**



**Department of Microbiology
Shri Shivaji Education Society, Amravati's
SCIENCE COLLEGE, CONGRESS NAGAR, NAGPUR-12**
Accredited with CGPA of 3.51 at 'A+' Grade by NAAC, Bangalore
A College with Potential for Excellence
An Institutional Member of APQN
Recognized Centre for Higher Learning & Research
A Mentor College under Paramarsh Scheme of UGC, New Delhi
A Mentor College under Paris Sparsh Scheme of Maharashtra State
An ISO 21001: 2018 Certified Institution

2023-2024

Table of Contents

Contents	Page no.
Declaration	I
Certificate of College/Institution	II
Certificate of Haldiram Industry	III
Acknowledgement	IV
Introduction	1
Plan of Work	3
Outcomes	38

DECLARATION

I, the undersigned here by declare that the on job training at "Haldiram Foods International, Pvt. Ltd., Nagpur" has been carried out under the guidance and supervision of Mr. Sanghshil Bansod, HR Manager, Haldiram Foods International, Pvt. Ltd., Nagpur and Dr. Pranita B. Gulhane, Assistant Professor & Supervisor, Department of Microbiology, S.S.E.S. A's Science College, Congress Nagar, Nagpur.

This on job training was for 126 hours that provided exposure to the industry in the form of internship.

Place- Nagpur

Date- 15/06/24

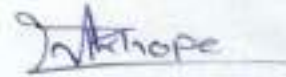

- Ms. Anuradha P. khope

CERTIFICATE

This is to certify that the On Job Training present in this training report entitled "Microbiological Food Analysis" conducted at Haldiram's Foods International, Pvt. Ltd., Nagpur in association with P.G Department of Microbiology S.S.E.S. A's Science College, Congress Nagar, Nagpur under my supervision.

This training report has not been submitted earlier to any other University/Institution for the award of any degree or diploma.

Place- Nagpur

Date- 15/06/24

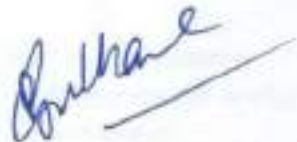

Dr. Pranita B. Gulhane
Assistant Professor & Supervisor
Department of Microbiology
Science College, Congress Nagar, Nagpur

Assistant Professor,
Department of Microbiology
S.S.E.S., Amt's
Science College, Nagpur

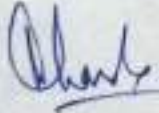
Evaluated

FI No. : 27AAACH362BL12G
No. : U15100MH1987PTC045509



HALDIRAM FOODS INTERNATIONAL PVT LTD

'Haldiram House', Plot No. 145, Old Pardi Naka, Bhandara Road, Nagpur-440 035, (M.S.), INDIA
Mobile : +91 9764449796, +91 9607678600, Email : hr@haldirams.com, Web : www.haldirams.com

HF IPL/HR/2024/JUNE/IS/00004

DATE: - 06 - April -2024

TO WHOMSOEVER IT MAY CONCERN

This is to certify that **Ms. Anuradha Purushottam Khope** a student of **S.S.E.S.A's Science College, Congress Nagar, Nagpur** has completed her Internship in **Quality Department** under the supervision of **Mr. Sanghashil Bansod (Assistant Manager- Quality Assurance)**.

She has completed training of **126 Hrs** from **18th March 2024** to **06th April 2024** in our organisation at **Unit Central Lab**.

During this period, she successfully completed the task assigned to her. She has been sincere, hardworking and punctual in her internship tenure.

For **Haldiram Foods International Pvt Ltd.**

Satya Prakash Tiwari
General Manager HR



ACKNOWLEDGEMENT

Special thanks to Hon'ble Prof. M.P. Dhore, Principal, Science College, Congress Nagar, Nagpur for providing the platform to carry out On Job Training. I am grateful for his moral support throughout this training period.

It is indeed my proud privilege to express deep sense of gratitude to my admired teacher, Dr. Pranita B. Gulhane, Assistant professor & Supervisor, Department of Microbiology, Science College, Congress Nagar, Nagpur for her immense help, cooperation, and valuable guidance that she has extended to me for the successful completion of this training.

I express my sincere gratitude and thanks to all the teachers, Ms. Ankita Manapure, Ms. Sayali Sangole and Ms. Anjali Pogade of the department for their academic help during the period of my training.

I would sincerely like to thank "HALDIRAM FOODS INTERNATIONAL, PVT. LTD., NAGPUR" for giving me opportunity to work at their premises and use their resources as and when required.

I acknowledge to Mr. Sanghshil Bansod, HR Manager, Haldiram's Food International, Pvt. Ltd., Nagpur for the efforts in making possible for me to carry out my training successfully.

I express sincere thanks to my parents for their immense support, love and care as well as thanks to my friends who gave moral support and shared a great moment together.

I would like to praise and thank God, the Almighty, who has granted countless blessings, knowledge, and opportunity to the writer, so that I have been able to accomplish the training.

- Ms. Anuradha P. khope

INTRODUCTION

Haldiram's is a well-known Indian snack and sweets brand, with its origins in Nagpur, Maharashtra. Founded in 1937 by Shri Ganga Bhishen Agrawal, it started as a small, sweet shop in Bikaner, Rajasthan. This modest shop quickly gained popularity and scaled up to meet a booming demand for its unique tasting bhujia. Building on this legacy, his grandson, its pioneer Mr. Shiv Kishan Agrawal steered the business towards the heights it has tasted today.

Haldiram's Nagpur is particularly renowned for its wide range of snacks, sweets, and ready-to-eat food products. Some of their most popular items include bhujia, namkeens, samosas, and various traditional sweets like rasgulla and gulabjamun.

Over the years, Haldiram's has not only maintained the quality and authenticity of its products but has also expanded its presence nationally and internationally. It operates numerous outlets across India and has a global reach, making it a favorite choice for those seeking traditional Indian snacks and sweets.

The success of Haldiram's Nagpur can be attributed to its commitment to quality, hygienic production processes, and a diverse product range that caters to a wide array of tastes. It remains a beloved brand for food enthusiasts both in India and abroad.

Certifications:

- **BRCGS Food Safety Global Standard**
- **Food Safety and Standards Authority of India**
- **FSSC 22000**
- **Halal Food Certified**
- **ISO-22000 FOOD SAFETY MANAGEMENT**

CENTRAL LAB

Haldiram's Central Lab in Kapsi, Nagpur, where they conduct quality control of their product. This central lab plays a crucial role in ensuring that the product company's high-quality standards comply with food safety regulations.

Given below are details on the three subsidiary laboratories operating within the laboratory structure. These specialized labs are committed to distinct sets of parameters, each with its own specific focus on testing and analyzing.

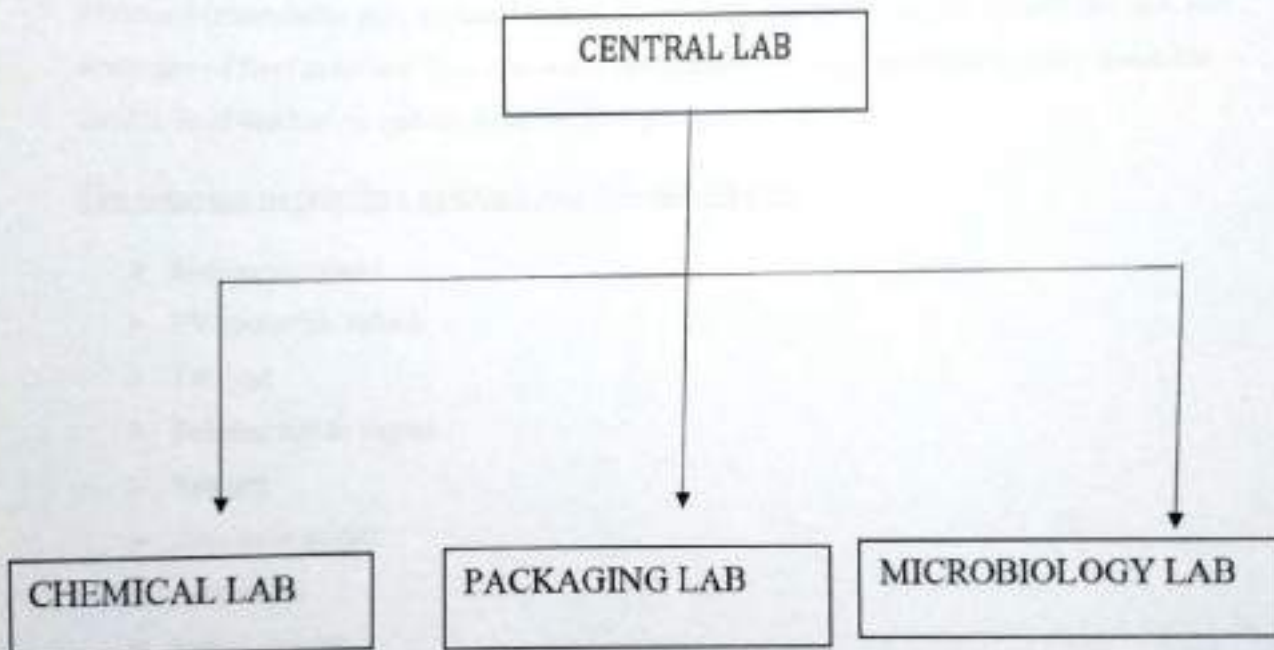

PLAN OF WORK

1. Chemical Lab
2. Packaging Lab
3. Microbiology Lab
4. Instrumentation

CHEMICAL LAB

Chemical laboratories play a crucial role in maintaining and enhancing the quality, texture, and aesthetics of food products. This involves a comprehensive analysis of both the raw materials used in food production and the final finished goods.

The common parameters analyzed and determined are:

- Moisture content
- PV (peroxide value)
- Fat Test
- Sulphur test in sugars
- Salt test
- Alcoholic acidity
- Acid value
- Iodine content
- Iodine value
- FFA (Free Fatty Acid)
- Saponification value
- Gluten content
- TBHQ (Tertiary butyl Hydroquinone)

Moisture Content

A) By using oven method:

Aim: - To determine the moisture content of a sample by using an oven.

Principle: - Moisture content refers to amount of water present in a material, usually expressed in a percentage of the material total weight. It is a crucial parameter in various and significantly affect the properties, quality, and shelf life.

Procedure: -

1. Weigh accurately about 5 gm of sample in a previously dried and tared dish.
2. Place the dish with its lid underneath in the oven maintained at 130°C for 2 hours.
3. The time should be recorded from the time the oven attains 130°C after dish is placed.
4. Remove the dish after 2 hours, cool in the desiccator and weigh.

Formula: -

$$\text{Moisture (\%)} = \frac{(W1 - W2) \times 100}{W1 - W2}$$

Where,

W1 = weight of empty dish.

W2 = weight of dish with sample before drying.

B) By using Moisture Analyzer.

Aim: - To determine the moisture content of a sample quickly and accurately using a moisture analyzer.

Requirements: - Moisture analyzer, sample, aluminum plate.

Procedure: -

1. Weigh a clean and dry aluminum plate using an analytical balance and record its weight.
2. Transfer the sample onto the plate and record the combined weight.
3. Turn on the moisture analyzer and allow it to warm up and reach the desired operating temperature.
4. Place the sample into the moisture analyzer.
5. Analysis process involves heating the sample and measuring the weight change as moisture evaporates.

Peroxide Value

Aim: -Determination of peroxide value of given sample.

Reagent: -Acetic acid chloroform solvent mixture in 3:2 ratio, freshly prepared saturated potassium iodine solution, 0.1 N sodium thiosulphate solution.

Principle: - It is defined as the mill equivalent of peroxide per kilo gram of sample. The PV of an oil or fat is used as a measurement of the extent to which rancid reactions have occurred during storage.

Procedure: -

1. Weigh 5g sample into a conical flask.
2. Add 30 ml of acetic acid chloroform solvent and swirl then add 0.5 ml saturated potassium iodide solution with a pipette and place it in a dark room.
3. Then add about 30 ml water.
4. Add about 0.5ml starch solution as an indicator.
5. Perform titration with 0.01 N sodium thiosulphate.
6. Shake till the color disappears.

Formula: -

$$PV = \frac{\text{Burette reading} \times \text{Normality of sodium thiosulphate} \times 1000}{\text{Weight of sample}}$$

Fat content by Soxhlet method

Aim: - To determine the fat content present in the sample.

Material and equipment: - Sample to be analyzed volatile solvent, Soxhlet extraction apparatus, extraction flask, condenser, siphon, extraction thimble, balance for weighing, heat source, flask, beaker.

Procedure: -

1. Firstly, take the initial weight.
2. Take 5-10 gm of sample into filter paper thimble.
3. Plug the thimble by using tissue paper.
4. Assemble the Soxhlet extraction apparatus.
5. Add 200 ml hexane into extraction flask.
6. Connect the extraction chamber to the extraction flask.
7. Attach condenser vertically above the extraction chamber.
8. Heat the extraction flask containing the solvent.
9. Remove extraction flask after 6 hr. from Soxhlet apparatus and keep into water bath for 1 to 2 hrs.
10. Keep in desiccator for cooling.
11. Measure the final weight.

Formula-

$$\text{Fat content} = \frac{(\text{Final weight} - \text{Initial weight}) \times 100}{\text{Weight of sample}}$$

Sulphur Test in Sugars

Aim: To determine Sulphur test in sugars

Material: Sugar samples, sulfuric acid, sodium hydroxide, pipettes, beakers, conical flask, burette, burette stand, distilled water, iodine solution, starch solution etc.

Principle: Sulphur reducing bacteria can metabolize Sulphur containing compounds present in the culture medium and reduce the Sulphur to hydrogen sulfide. The released hydrogen sulfide reacts with an indicator to form black- colored insoluble components which turn the whole medium black.

Procedure:

1. Take 25 g sample in conical flask and add 100 ml water. If the sample is liquid, then 100 ml water is not required and mix well.
2. Then add 25 ml 1N NaOH and keep it for 30 minutes and add 6N 10 ml H₂SO₄ after that titrate with 0.1 N iodine solution using starch solution as indicator.
3. The end point will be light bluish color.

Formula: -

$$SO_2 = \frac{32 \times \text{Normality of iodine solution} \times \text{Burette reading} \times 1000}{\text{Weight of sample}}$$

Salt content in food sample

Aim: Determination of salt content in food sample

Material: Conical flask, burette, burette stand, distilled water, 0.1 N silver nitrate and 5% potassium chromate.

Principle: When a sample extract containing sodium chloride to which a few drops of potassium chromate solution is added is titrated with standard silver nitrate solution. Silver nitrate precipitates chloride as silver chloride. Immediately on completion of the precipitation reaction, the excess of silver nitrate reacts with potassium chromate forming reddish brown silver chromate, which is the end point. The quantity of silver nitrate used for the precipitation is the measure of the sodium chloride content of the sample.

Procedure:

1. Take 2 g sample in conical flask and add 100 ml water and mix it well.
2. Then titrate with 0.1 N silver nitrate solution using 5% potassium chromate as an indicator.
3. The end point will be reddish color.

Formula:

$$\text{Salt \%} = \frac{5.85 \times \text{Burette reading} \times \text{Normality of silver nitrate}}{\text{Weight of sample}}$$

Alcoholic Acidity

Aim: To determine the alcoholic acidity of the sample.

Material and equipment: Food sample, Ethanol, phenolphthalein indicator, sodium hydroxide, burette, pipette.

Procedure:

1. Take a sample of 5 gm into conical flask.
2. Dissolve sample with neutralized ethanol 50ml.
3. Use filter solution by filter paper.
4. Use 10ml filtrate and add phenolphthalein indicator till it gives pink color.
5. Titrate against 0.1 N of NaOH solution.
6. We get B.R reading till it gives the end point.

Formula:

$$\text{Alcoholic acidity} = \frac{(24.52 \times \text{B.R} \times \text{N of NaOH}) \times 100}{\text{Weight of sample}}$$

Acid Value

Aim: - To determine the acid value of the food sample.

Material and Equipment: - Food sample (e.g. edible oil), burette, Conical flask, pipettes, Heating source (e.g. hot plate or Bunsen burner), analytical balance.

Reagent: - Ethyl alcohol (95 % ethanol), Phenolphthalein indicator solution, Sodium hydroxide (NaOH) solution.

Procedure: -

1. Take 2-3 gm oil sample into conical sample.
2. Dissolve 50ml neutralized ethanol into sample.
3. Add phenolphthalein indicator about 2-3 drops.
4. Heat the sample on Bunsen burner or hot plate for 15 minutes.
5. After heating let it cool in condenser.
6. Titrate against 0.1 N of NaOH solution of 100ml.
7. Check burette reading after pink color endpoint.

Formula:

$$\text{Acid value} = \frac{(56.1 \times \text{burette reading} \times \text{N of NaOH})}{\text{Weight of sample}}$$

Iodine content

Aim: - To determine the iodine content in salt.

Reagents: - Potassium iodide solution, Sodium thiosulphate solution, 1% starch indicator.

Procedure: -

1. Take 10 g sample in stopper flask / IV flask.
2. Then add 50ml Distilled water and shake to dissolve the sample.
3. Then add 2N 5ml H_2SO_4 and again add 5ml 10% KI solution.
4. Then close the lid and place it in a dark place for 10 minutes.
5. After 10 minutes titrate with 0.005N sodium thiosulphate solution using 1% starch as an indicator.
6. The end point will be bluish to colorless.

Formula: -

$$\text{Iodine content} = \frac{\text{Burette reading} \times \text{Normality of sodium thiosulfate} \times 21140}{\text{Weight of sample}}$$

Iodine value

Aim: - To determine iodine value of a given sample.

Reagents: - carbon tetrachloride, wijs solution, 10% potassium iodide.

Principle: - To measure the degree of unsaturation.

Procedure: -

1. Take Weight of sample 0.2 g according to IV and add 25ml of carbon tetrachloride then add 25ml of wijs solution and close the stopper and keep it for 30 minutes. Simultaneously conduct the blank.
2. After 30 minutes add 100ml distilled water and 15ml 10% KI solution.
3. Then titrate the solution with 0.1N sodium thiosulphate using 1% starch as an indicator. Conduct also blank.
4. The end point will be bluish to colorless.

Formula: -

$$\text{Iodine value} = \frac{12.69 \times (\text{Blank} - \text{Sample}) \times \text{Normality of sodium thiosulfate}}{\text{Weight of sample}}$$

Free fatty acid

Aim: - Determination of free fatty acid.

Principle: - The free fatty acid in oil can be determined volumetrically by titrating the sample with potassium hydroxide in the presence of phenolphthalein indicator. The acid number is defined as the mg KOH Requires to neutralize free fatty acids Present in one gram of sample.

Procedure: -

1. Take 50 ml ethanol and neutralize it by NaOH
2. then add phenolphthalein indicator.
3. After adding phenolphthalein indicator light pink color formed.
4. Then add this to sample.
5. Then heat it by Soxhlet apparatus.
6. After heating add NaOH by titration.

Formula:

$$\text{FFA} = \frac{\text{BR} \times \text{Factor (28.2)} \times \text{N (0.1)}}{\text{Sample weight.}}$$

Where, BR = burette reading

N = normality

Saponification Value(SV)

Aim: - To determine the fatty acid present in the sample

Reagents: - Alcoholic KOH, ethyl alcohol, phenolphthalein indicator.

Principle: - The alkali breaks the ester band and release the fatty acid salt and glycerol. Higher the saponification value greater is the percentage of the short chain acids present in the glycerides of the oils or fats.

Procedure: -

1. Take 1.5 to 2.5 g sample in round bottom flask.
2. Add 25 ml alcoholic KOH conduct blank also.
3. Reflux while solution is clear.
4. Wash the condenser with 10 ml neutralize Ethyl alcohol.
5. Titrate with 0.5 N HCL using phenolphthalein indicator.
6. End point will be pink to colorless.

Formula: -

$$\text{Saponification value} = \frac{56.1 \times (\text{Blank} - \text{Sample}) \times \text{Normality of HCL}}{\text{Weight of sample}}$$

Gluten Content: -

Aim: Wheat and other related grains (including barley and rye) contain a mixture of two proteins gluten in when flour made from grinding these grains is mixed with water the two proteins combine and form gluten without water, gluten is not formed.

Procedure:

1. The dough is prepared from flour in a buffered solution of sodium chloride.
2. The wet gluten is then isolated by washing this dough with a solution of sodium chloride. Followed by removal of excess washing solution.
3. Desiccation at 130° C for 2hr.
4. Weighing of ball of gluten obtained.

Formula:

$$\text{Gluten content} = \frac{(\text{Final wt. of Petridis} - \text{Initial wt. of Petridish}) \times 1000}{\text{Weight of sample} \times [100 - \text{Moisture}]}$$

Tertiary Butyl Hydroxy Quinone

Aim: - Determination of tertiary butyl hydroxy quinone.

Principle: - tertiary butyl hydroxy quinone (TBHQ) is a synthetic aromatic organic compound, which is a type of phenol. It is a derivative of hydroquinone. It is used in the food industry to extend the shelf life of the various products. Including oils and fats. It is added to food and edible oils to prevent oxidation and rancidity, which can lead to off-flavors and spoilage.

Procedure: -

1. Take 3 to 5 ml of oil sample in a test tube.
2. Add dimethylamine 40% solution.
3. This solution oxidizes the TBHQ in the oil.
4. Vigorously shake the mixture, if red color appears TBHQ is present, otherwise absent.

PACKAGING LAB

A package lab, often referred to as a packing testing or quality control laboratory is a specialized facility dedicated to assessing and ensuring the quality, safety and performance of packing materials and products. These labs play a crucial role in various industries including food and beverage, pharmaceuticals, cosmetics, electronics, and more.

The Types of packaging material are:

1. Laminate, Pouches and folds.
2. Cartons

A list of parameters commonly measured in a chemical lab, which be relevant to

- Packaging testing
- Dimensions
- Layer separation.
- GSM
- Thickness testing.
- Bursting strength
- Moisture Analysis

Functions of each of the four layers in the Laminate

1. PET (Polyethylene terephthalate)

Functions:

- PET is often used as the outer layer of laminates in food packaging provide strength, rigidity, protection to the contents Characteristics.
- PET is transparent,
- lightweight, and has good barrier properties against oxygen.

2. MET (Metalized Polyester):

Functions:

- MET is metalized usually applies to polyester film. It serves as a barrier to light, moisture, and gases, enhancing the product's shelf life.

Characteristics:

- MET has a reflective, metallic appearance and is often used to create a shiny, eye catching appearance on packaging.

3. Poly (Polyethylene):

Functions:

- The Polyethylene layer provides a moisture barrier and helps protect the contents from external moisture or liquid. It also enhances the flexibility of the laminate.

Characteristics:

- Polyethylene is a widely used polymer known for its water-resistant properties and flexibility.

4. Extruded poly (Extruded Polypropylene or Similar Material):

Functions:

- The Extruded poly layer can provide additional strength and stiffness to the laminate. It contributes to the overall structure and stability of the packaging.

Characteristics:

- Extruded Polypropylene or similar materials are known for their durability and resistance to impact and tearing.

LAYER SEPARATION

Aim: To separate layers of the laminate using chloroform.

Apparatus: - Laminate sheet, Beaker, Chloroform.

Laminate Composition

- The laminate consists of four layers: PET, MET, Poly, e-Poly.
- The layers are typically used in various types of flexible packaging materials.

Dipping in chloroform

- Chloroform is a solvent that can dissolve certain types of plastics. In this experiment, the laminate is immersed or dipped into chloroform for a specific duration, which is 10 hours in this case.
- The objective is to see how the layers of the laminate react to the solvent over time.

Layer Separation:

- As a result of the immersion in chloroform, the four layers of the laminate be separated from each other.
- This separation occurs because the chloroform can penetrate and weaken intermolecular forces holding the layers together.

DIMENSIONS:

Aim: To measure the dimensions (length, breath, and height of laminates, cartons, and corrugated boxes used in food packing materials

Apparatus: Measuring tape or ruler.

Procedure: -

Prepare the work area:

- Ensure you have a clean and unobstructed surface to work on.
- Make sure the laminates, cartons, or corrugated boxes are clean and free from any debris.

Select the Measurement Unit:

- Determine whether you will be using millimeters (mm), centimeters (cm), or meters (m) as your unit of measurement.
- Ensure consistency throughout the measurement process.

Measuring length:

- Place the object on a flat, level surface.
- Use the measuring tape or ruler to measure the length of the object from one to the other.
- Ensure that the measuring tape is straight and not sagging.

Measuring Breadth:

- For 2D objects like laminates, measure the breadth by using the measuring or ruler across the width of the object.
- For 3D objects like cartons or corrugated boxes, measure a suitable reference point (e.g., a corner) and measure width.

GRAM SQUARE METRE (GSM)

Aim: - To determine the Grams per Square Meter (GSM) of laminates and packaging material.

Apparatus: - laminates or packaging material sample, Precision Digital Balance

Procedure: -

Prepare the sample:

- Ensure that the laminates or packaging material is clean and free from any debris.
- Using a metal plate of 10 by 10 cm, cut a square sample with sides measuring 10x10 centimeters. You can use a ruler to measure and mark the dimensions accurately before cutting.

Weigh the sample:

- Place the cut sample on the precision digital balance.
- Record the weight of the sample in grams (g) accurately. Note this weight in your notebook.

Calculations:

- Formula for GSM is weight of sample $\times 100$.

THICKNESS TESTING

Aim: To check the thickness of the separated layers of laminate.

Apparatus: Weighing balance, separated layers of laminate.

Principle: Many physical and mechanical properties of cartons, paperboard, laminates, and flexible packaging materials are dependent upon the thickness of the material. Properties like tensile strength, seal ability, and seal strength, moisture, gas and light barrier properties are directly related to thickness. Variation in the thickness can lead to variations in those mechanical properties. Thickness is defined as the perpendicular distance between two principal surfaces of the sample substrate.

In the case of laminates, the thickness of the constituent plies is more important as they influence the barrier properties. This test is useful for routine control. Each one of the laminate layers performs a unique barrier function for protecting the contents from external influences such as oxygen, light, moisture, other chemicals, and microbial materials. Typically, conventional polymers used for packaging include polyethylene terephthalate (PET), metallized polyethylene terephthalate (MET), Polyester and extruded polyester.

Procedure:

1. Cut a piece from separated layer of laminate without any irregularities of size 10 cm x 10 cm.
2. Take the weight of any separated layer of laminate, for example PET.
3. The numeric value of the density for PET and MET is 1.4

4. The numeric value of the density for polyester and extruded polyester is 0.92.

Calculation:

Formula for the calculation of the thickness of laminate is.

$$\text{Thickness (in micron)} = \frac{\text{Weight of sample}}{\text{Density}}$$

DETERMINATION OF MOISTURE CONTENT IN FOOD PACKAGING CARTONS

Aim: To quantify the moisture content present in food packaging cartons.

Apparatus: Food packaging cartons, Digital Moisture Meter, Weighing dish, Gloves, Scissors.

Procedure:

1. Sample Preparation:

- Collect representative samples of the food packaging cartons.
- Cut the cartons into small, uniform pieces using scissors or a cutting tool.
- Transfer the carton pieces into a weighing dish and record the initial weight.

2. Moisture Analysis:

- Place the weighing dishes containing the carton pieces into the moisture analyzer at 105°C.
- Wait for 5 min.
- After beeping, observe the moisture content displayed on the moisture analyzer.

Observations and Analysis:

- Compare the moisture content of different carton samples and draw conclusions about their suitability for food packaging applications.
- The moisture should be between 8-12. If moisture is not within this limit, then the carton is rejected.

Conclusion:

This experiment provides a reliable method for determining the moisture content in food packaging cartons, which is crucial for assessing their quality and performance in food preservation applications.

INSTRUMENTATION FOR FOOD PACKING

- Compression Testing Machine.
- JSR Thickness Micrometer.
- Bursting Strength testing

Aim: - To investigate the role of instruments in ensuring the Food Packaging industry.

1) COMPRESSION TESTING MACHINE

Principle

Industry can assess their ability to withstand these pressures without deforming or failing, ensuring the integrity and safety of packaged food products. Compression testing machines typically consist of a stationary base and a moving crosshead that applies force to the specimen at a controlled rate. As force is applied, the machine measures the deformation or displacement of the packaging material, allowing for the determination of compressive strength, stiffness, and other mechanical properties. This helps packaging manufactures and food companies optimize packaging designs and materials to provide adequate protection for food products throughout the supply chain.



2) BURSTING STRENGTH MACHINE

Principle

A Bursting Strength Tester is a widely used paper and packaging testing instrument that measures the ability of a material to withstand pressure or external forces. This type of tester is often used to test the strength of paper, cardboard, and packaging materials, as well as fabrics, plastics, and other materials. The tester works by applying hydraulic pressure to a sample of the material, which is placed between two circular clamps. The pressure is gradually increased until the material bursts, and the maximum pressure that the material can withstand is recorded as its bursting strength.

Bursting strength is an important property of paper and packaging materials, as it can determine their ability to protect and contain the products they are designed to hold. The tester can also be used to determine the quality of the material, and to ensure that it meets industry standards and regulations.



3) JSR THICKNESS METER

Principle

The principle of JSR thickness meter in food packaging laboratory involves measuring the thickness of packaging materials with precision. The equipment typically utilizes non-destructive testing methods, determining the thickness of materials like plastic films, paperboard, or aluminum foil.



MICROBIOLOGY LAB

Microbiology lab in a food industry plays a crucial role ensuring the safety and quality of food products here are some key aspects and activities that are typically associated Microbiology lab in the food industry.

Microbial Testing: One of the primary functions of the microbiology lab is to conduct microbial testing on food samples. This includes testing for bacteria, yeast, mold, and other microorganisms that can spoil food or pose a health risk to consumers. Common tests include total plate count, coliform, E. coli testing, salmonella detection, Listeria testing, etc.

Pathogen Detection: Detecting and identifying pathogenic microorganisms such as salmonella, E. coli, campylobacter and Listeria is crucial to ensure that food products are safe for consumption. Rapid and accurate detection methods are employed to prevent food born illnesses.

Environmental Monitoring: Monitoring the Microbiology quality of the food processing environment is vital to prevent contamination. Regular swabbing and testing equipment, surfaces and air quality help maintain a clean and safe production environment.

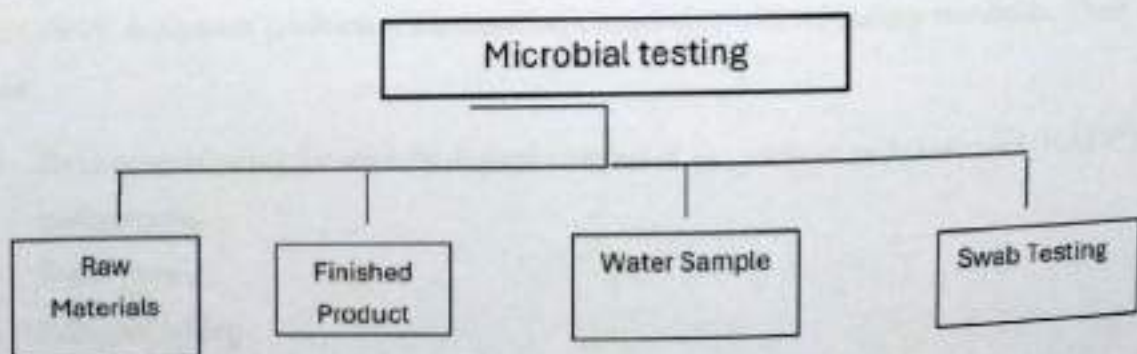

Importance Of Microbiological Testing in Food and Beverages

Identification of pathogen and food spoilage microorganisms is a vital part of food microbiology to ensure consumer safety, prevent brand desecration, and minimize costly mitigation following failed inspections or food poisoning outbreaks.

Key factors to be considered in a microbial testing program include frequency of testing, ideal production stage for testing, matrix or product composition, target spoilage organism, and testing methods.

Bacterial and fungal contamination in food production is associated with various foodborne illnesses with symptoms that range from mild nausea to severe gastrointestinal poisoning and death.

Microbial spoilage screening of beverages is also crucial to ensure the release of safe drinks to the market.

Loss through spoilage can be costly for producers of beverages, irrespective of whether it affects ingredients or a finished product. It may have even more severe consequences when the spoiled final product reaches the market. In addition to the monetary loss incurred because of the bad product and its recall, customer confidence and the brand image may also be seriously degraded.

Microbial tests ranging from quantitative and qualitative significantly contribute to the identification of food and outbreak of foodborne diseases. These routine tests can be used to validate primary control methods, such as the Hazard Analysis and Critical Control Point (HACCP) system. Routine microbiological solutions cover the entire production process through to the QA/QC analysis of products while ensuring compliance with regulatory standards. They include:

- Hygiene monitoring for microbiological analysis of air, surfaces and personnel (HACCP management)
- Water testing
- Pathogen testing
- Indicator organism testing and spoilage organism testing.

PATHOGENIC BACTERIA

Pathogenic bacteria are those that cause disease, are transmitted through direct contact with an infected host, by ingestion of contaminated food or water.

E. coli

E. coli is Gram-negative straight rod, 2 micron long, 0.5-micron diameter arranged in pairs. It is motile by peritrichous flagella, though some strains are non-motile. Spores are not formed. Capsules and fimbriae are found in some strains. Enrichment and selective procedures are used to provide a reasonably sensitive, definitive and versatile means of qualitatively isolating all members of *E. coli*.

Testing of *E. coli* in food sample

Pre enrichment: 25 g of sample in 225 mL buffer peptone water.



Post enrichment: Add 1 mL sample in LST broth with Durham's tube and incubate at 37°C for 24 hrs.

Results

Negative results: No gas production and turbidity. No further proceedings.

Isolation: Take loopful of sample from positive tube and streak it on EMB agar plates. Incubate it at 37°C for 24 hrs. Colonies with green metallic sheen indicates the presence of *E. coli*.

SALMONELLA

Salmonella consists of bacilli leading to enteric fever gastroenteritis, septicemia, etc., the most important member of genus is *Salmonella typhi* which causes typhoid fever.

Size: 2-5 micron long & 0.7-1.5-micron diameter

Morphology: rod shape, gram negative, non-spore forming, motile with peritrichous flagella except for *S. Gallinarum pullorum*.

Cultural characteristics: *Salmonella* are aerobic and facultative anaerobic bacteria growing on simple media over range 6-8 pH and at 37°C temp. colonies are larger circular and smooth on SS agar with black color selenite F broth is employed as enrichment broth.

Biochemical reaction: *Salmonella* are facultative anaerobes, ferment glucose & mannitol forming acid and gas, indole negative, they are MR positive, VP negative, citrate positive, peroxidase negative.

Testing of Salmonella

1. Pre enrichment: 25 g of sample in 225 mL buffer peptone water.
2. Post enrichment: 1 ml sample in cysteine selenite F broth and incubate at 42°C for 24 hrs.
3. Selective enrichment: Streak loopful of sample from selenite F broth tubes on SS agar plates. Incubate at 37°C for 24 hrs. Black colonies indicate positive results.
4. Biochemical tests: Streak loopful of sample from SS agar on urease slant and incubate it at 37°C for 24-48 hrs.

Pink color: *Salmonella* absent.

Yellow color: *Salmonella* present.

STAPHYLOCOCCUS AUREUS

Staphylococcus aureus is a gram-positive opportunistic pathogen most commonly associated with skin and soft tissue infections. It is catalase-positive, coagulase-positive cocci in clusters.

Testing for *S. aureus*

1. Pre-enrichment: 25 g of sample in 225 mL buffer peptone water.
2. Post-enrichment: 1 mL sample on Baird-Parker agar. Incubate at 37°C for 24-48 hrs. *S. aureus* colonies typically appear greyish-black and shiny.
3. Isolation: Select colonies that appear typical of *S. aureus* and streak them onto fresh Baird-Parker agar plates to obtain pure cultures.

NON-PATHOGENIC BACTERIA

Nonpathogenic: Non- pathogenic microorganisms do not cause diseases in their host organisms. Under normal circumstances they do not possess the virulence factor necessary to cause diseases.

Ex: Coliforms, TPC, Yeast and Molds.

COLIFORMS

Coliform bacteria are commonly used as an indicator of stationary quality of food and water. They are defined as rod shaped gram negative non spore forming and motile or non-motile bacteria which ferment lactose with the production of acid and gas incubating at 35-37°C for 24-48 hrs. Coliform bacteria found in aquatic environment in soil and on vegetation they are usually present in large number in feces of warm blooded animal while coliform themselves are not normally cause of serious illness they are easy to culture. Size and color of coliform on VRBA pink, red color colonies 0.5 mm in diameter & 2micron long or large surrounded by zone of precipitated bile acid.

Preparation of Violet Red Bile Agar media:

The media were prepared by suspending 20.75 gm Violet Red Bile Agar in 500ml distilled water. The media were heated to boiling with gentle swirling to dissolve completely. The media were sterilized by autoclaving at 121°C for 20 minutes at 15lbs pressure. Overheating was avoided. Then the media were cooled to 45-50°C and poured into sterile petri dish. The surface of the medium was dried when inoculated.

Procedure:

1. Make a solution of 90ml saline solution then add 10gm of sample.
2. Make the dilutions.
3. Saline solution maintains ph.
4. By pouring plate technique add 1ml of sample from this solution in Violet red bile agar (VRBA).
5. Incubate at 37 °C for 24 hours.

Interpretation: After incubation if pink colony appears that means test for coliforms is positive.

TOTAL PLATE COUNT (TPC)

Total Plate Count (TPC) is a method of estimating the total number of microorganisms (mold, yeast, bacteria) in a material. The research begins with the dilution phase of the sample. This quantitative analysis Plate count (PC) agar is used for TPC. As PC agar is nonselective media there will be no colored colonies.

Preparation of PC agar:

1. Suspend 23.5 grams in 1000 ml distilled water.
2. Heat to boiling to dissolve the medium completely.
3. Sterilize by autoclaving at 15 lbs. pressure (121°C) for 15 minutes.
4. Cool to 45-50°C.
5. Mix well and pour into sterile Petri plates.

Procedure:

1. Make a solution of 90ml saline solution then add 10gm of sample.
2. Make the dilutions.
3. Saline solution maintains PH.
4. By pour plate technique add 1ml of sample from this solution in plate count agar (PC).
5. Incubate at 37°C for 24 hours.
6. After incubation a number of colonies appear.

YEAST AND MOLDS

The large and diverse group of microscopic foodborne yeasts and molds (fungi) includes several hundred species. The ability of these organisms to attack many foods is due in large part to their relatively versatile, environmental requirements. Although all yeasts and molds are obligatory aerobes (require free oxygen for growth), their acid/alkaline requirement for growth is quite broad, ranging from pH 2 to above pH 9. Their temperature range (10-35°C) is also broad, with a few species capable of growth below or above this range.

Preparation of Chloramphenicol yeast glucose agar (CYGA):

1. Add 40.00 gm powder to 1.0 liter of distilled/deionized water and mix thoroughly.
2. Gently heat and bring to boiling.
3. Autoclave at 15 psi pressure at 121°C for 15 minutes.

Procedure:

1. Make 90ml saline solution, then add 10gm of sample.
2. Make the Dilutions.
3. By pouring plate technique add 1ml of sample from this solution in chloramphenicol yeast glucose agar.
4. Incubate at 37°C for 24 hours.

Observation: After incubation for yeast white colonies appear and for molds black filamentous colonies appear.

MOST PROBABLE NUMBER (MPN)

Most Probable Number (MPN) is used to estimate the concentration of viable microorganisms in a sample by means of replicating liquid broth growth in ten-fold dilutions. It is commonly used in estimating microbial populations in soils, waters, and agricultural products. MPN test is particularly useful with samples that contain particulate material that interferes with plate count enumeration methods.

Principle: -

Water to be tested is diluted serially and inoculated in lactose broth, coliforms if present in water utilizes the lactose present in the medium to produce acid and gas. The presence of acid is indicated by the color change of the medium and the presence of gas is detected as gas bubbles collected in the inverted Durham tube present in the medium. The number of total coliforms is determined by counting the number of tubes giving positive reaction (*i.e. both color change and gas production*) and comparing the pattern of positive results (*the number of tubes showing growth at each dilution*) with standard statistical tables.

Formula: -

$$\text{MPN/100mL} = \frac{\text{Number of positive tubes} \times 100}{\sqrt{(\text{ml of sample in negative tubes})} \times \sqrt{(\text{ml of sample in all tubes})}}$$

MPN test is performed in 3 steps.

1. Presumptive test
2. Confirmatory test
3. Completed test.

INSTRUMENTATION

Laminar Air Flow Hood or Cabinets: A laminar cabinet is a carefully enclosed bench designed to prevent contamination of microbiological or biological samples or any sensitive material. HEPA filters are composed of a mat of randomly arranged fibers. The fibers are typically composed of fiber glass and process diameter 0.5-2.0 micrometer. The air space between HEPA filter fibers is typically not much greater than 0.3 μm the common assumption that HEPA filter act like sieve where particle smaller than the largest opening can pass through is incorrect and impractical.

Autoclave: An autoclave is a machine used for sterilizing equipment and materials by subjecting them to high-pressure steam at temperatures typically between 121°C to 134°C (250°F to 273°F). This process effectively kills bacteria, viruses, spores, and other microorganisms, making the sterilized items safe for use in medical, laboratory, and industrial settings. The principle of the autoclave or steam sterilizers is that water boils when its vapors pressure equals that of the surrounding atmosphere.

Oven: Hot air ovens are electrical devices which use dry heat to sterilize. Generally, they can be operated from 50 to 300°C, using a thermostat to control the temperature. Their double walled insulation keeps the heat in and conserves energy, the inner layer being a poor conductor and outer layer being metallic. There is also an air-filled space in between to aid insulation. An air circulating fan helps in uniform distribution of the heat.

Incubator: The principle of an incubator is to provide a controlled environment with stable temperature, humidity, and sometimes CO₂ levels to support the growth and cultivation of microorganisms, cells, tissues, or organisms under controlled conditions. An incubator is a device used to grow and maintain microbiological cultures or cell cultures. The most commonly used temperature both for bacteria such as the frequently used E. coli as well as for mammalian cells is approximately 37°C, as these organisms grow well under such conditions.

OUTCOMES

- Visually understand the system.
- Understood the need of chemical test, microbial test and packaging test.
- Testing during various production phases can help identify the cause of a production problem and the necessary corrective actions to prevent it from happening again.
- Objective of quality control. The first is to improve product quality and reduce risks. The second is to gain production efficiencies. And the third is to garner customer loyalty.
- It helps improve customers' satisfaction by consistently delivering quality products or services, reducing wastage of resources, and increasing efficiency and profits for the company.
- Product development or quality assurance roles require a variety of quality control skills.

**SHRI SHIVAJI EDUCATION SOCIETY AMRAVATI'S
SCIENCE COLLEGE, CONGRESS NAGAR, NAGPUR
P.G. Department of Microbiology
M.Sc. Ist Year Semester- II (2023-24)**

LIST OF ON JOB TRAINING STUDENTS

Sr. No	Name of Student
1.	Astha A. Sakharwade
2.	Akanksha R. Bisen
3.	Akanksha V. Tekade
4.	Anisha A. Shende
5.	Anuradha P. Khope
6.	Arshiya S. Mushtaque
7.	Arya S. Walode
8.	Bhisvani M. Dhurve
9.	Ishita Y. Padgil
10.	Ishwari N. Gawande
11.	Leena N. Meher
12.	Manisha G. Lilhare
13.	Manisha R. Roy
14.	Namrata O. Nagose
15.	Ojaswini R. Bhagat
16.	Rujuta R. Ramteke
17.	Shamim M. Shahzad
18.	Snehal N. Sahare
19.	Vaishnavi V. Ingle
20.	Vami K. Masram
21.	Yashoda R. Wade



Dr. Pranita B. Gulhane

**Department of Microbiology
Science College, Congress Nagar,
NAGPUR.**

Title - Apiculture (Honey Bee Farming)

Internship Report Submitted to

Shri Shivaji Education Society Amravati's

Science College

Congress Nagar, Nagpur

RTM, Nagpur University, Nagpur

Session - 2023-2024



Submitted by

AANCHAL ARVIND SHARMA

M.Sc. Zoology (Semester II)

Shri Shivaji Education Society Amravati's

Science College, Congress Nagar, Nagpur

Place of Internship

PG Department of Zoology

Hislop College, Civil line Nagpur

DECLARATION

I hereby declare that the Internship report titled Apiculture is bonafide work carried out by **AANCHAL ARVIND SHARMA** under guidance of team of on job training at Hislop College, Nagpur. Further I declare that this report has not been previously formed on job training programmed, has not been submitted anywhere else.



AANCHAL ARVIND SHARMA

Shri Shivaji Education Society Amravati's
Science College, Congress Nagar, Nagpur

DECLARATION FOR INTERNSHIP

Name of student	Aanchal A. Sharma
Residential Address	Kabul Road Nagpur - 440013
Permanent address	Kabul Road Nagpur, 440013
Email id	aanchalsharma35@gmail.com
Mobile number	9322361542
Aadhar Number	8315 1709 0607
PAN number	
Internship method	
Preferences for Internship	

I, undersigned, abide with all terms and conditions for internship.

Students' Signature: Aanchal

Date: 10/4/24

Ms./Mr. Aanchal A. Sharma has been participated and had submitted all the necessary documents and completed all the processes. I confirm all the processes and checked all the documents. He/she had permitted by his/her supervisor/in-charge for internship program.

Shubho

Head/Coordinator/ In-charge of Department

Signature and seal

Date:



Shri Shivaji Education Society, Amravati's
SCIENCE COLLEGE

Congress Nagar, Nagpur- 440 012 (M.S.) INDIA

- Tel : +91-712 - 2423432 (O) • Telefax : +91-712 - 2440955
- E-mail : shivajiscience_ngp@yahoo.com
- Web : www.sscnagpur.ac.in

Shri Harshvardhan P. Deshmukh
President

Prof. M. P. Dhore
Principal

- 'A+' Grade with 3.51 CGPA (3rd Cycle) Reassessment College by MMC, Bangalore
- A College with Potential for Excellence identified by UGC, New Delhi
- Member, APQN (Asia Pacific Quality Network)
- Recognized Centre for Higher Learning & Research
- Member College under Paramarsh Scheme UGC, New Delhi



Dr. Panjabrao alias
Bhausaheb Deshmukh
Founder President

No. Sc.

Date :

DEPARTMENT OF ZOOLOGY

CERTIFICATE

This is to certify that the Internship work entitled **Apiculture** has been successfully completed by **Aanchal Arvind Sharma** of M.Sc. Zoology Semester-II under the supervision of team of on job training at Hislop College, Nagpur for the submission to RTM Nagpur University, Nagpur in partial fulfilment for the requirement of the Degree of Master in Zoology for the academic year 2023 -2024.

Head of Department

Professor & Head
Department of Zoology,
Shri Shivaji Science College,
Congress Nagar, Nagpur-440

Phafu
20/6/24

CERTIFICATE OF ON JOB TRAINING

FOR POST-GRADUATE PROGRAM IN ZOOLOGY
In Commercial Bee-Keeping



Organized by



Technical Associate



Industrial Associate



Academic Associate

This certificate is awarded to

Aanchal Sharma

Shri Shivaji science College nagpur

on successfully completion of on job training on

Commercial Bee Keeping

conducted during March-April 2024.

Total hours engaged 120 hours & credits recommended are 4[#].

Premlata

Ms. Premlata

Aquasoil Pvt. Ltd
Mumbai

Prashant S. Shelke

Dr. Prashant S.
Shelke
Principal

Hislop College,
Nagpur

Vishwajit Pendsey

Dr. Vishwajit Pendsey
Principal

Dada Ramchand Bakhru Sindhu
Mahavidyalaya, Nagpur

as per NEP2020 Guidelines

Issued in April 2024 by AQUASOIL PVT. LTD, HISLOP COLLEGE NAGPUR and DADA RAMCHAND BAKHRU SINDHU MAHAVIDYALAYA, NAGPUR.

To view the score
sheet Scan



SCORE SHEET OF ON JOB TRAINING
FOR POSTGRADUATE COURSE IN ZOOLOGY

IN COMMERCIAL BEE KEEPING

Name of the student : Aanchal Sharma

Institute : Sri Shivaji science College nagpur

Modules	Max. Marks
Hive inspection	10
Morphometric study	10
Bee floral calendar	10
Quality Inspection of bee products	10
Making of byproduct	10
Total marks	50
Grade	O

This is to certify that examinee has handled all the modules and assessment sheets of the work has been submitted along with their report.

Dr. Ashish Kumar Jha
Trainer
Hislop College, Nagpur

Dr. Milind M. Shinkhede
Trainer
Dada Ramchand Bakhru Sindhu
Mahavidyalaya, Nagpur

Date : 12-04-2024

Marksheet Serial Code : Y24CB089

INDEX

sr. No.	Contents	Page No
1.	Day 1 :- Introduction 1.1 Field Visit 1.2 Inspection	5-9
2.	Day 2 2.1 Field Visit 2.2 Morphometric studies	10-14
3.	Day 3 3.1 Field Visit 3.2 Bee Box Measurement 3.3 Bee Hotel	15-18
4.	Day 4 4.1 Field Visit 4.2 Government & opportunities in private Sectors	19
5.	Day 5 5.1 Field Visit 5.2 Colony Division 5.3 Foundation Sheet	20-21
6.	Day 6 6.1 Familiarization with Bee Flora 6.2 Queen cell	22-24
7.	Day 7 7.1 Apitheraphy 7.2 Honey Marketing 7.3 Honey Products	25-27
8.	Day 8 Conclusion	28

Day 1

The on-job training duration was of 8 days. On day 1 we got an introduction of what we will do in upcoming days of training which was given by Dr. Ashish Jha sir, HOD, Department of Zoology, Hislop College, Nagpur. He gave brief introduction about honey bees, their hives or apiary, how they make honey in frame. They took us to the field where apiary were kept. Mrs. Mamta Bhadade and Ms. Vidhi maam guided us during the whole training process.

INTRODUCTION

- **Beekeeping** also known as **Apiculture** may be defined as the rearing and management of honey bees for commercial production of honey and other products of beehive.
- This method is practiced worldwide for various purposes, including honey production, pollination services for agriculture, production of other bee products like beeswax, royal jelly and propolis.
- Five important species of honey bees are as follows:
 1. The Rock Bee, *Apis dorsata* (Apidae).
 2. The Indian Hive Bee, *Apis cerana indica* (Apidae)
 3. The Little Bee, *Apis florea* (Apidae)
 4. The European or Italian Bee, *Apis mellifera* (Apidae)
 5. Dammer Bee or Stingless Bee, *Melipona irridipennis* (Meliporidae).

Commonly, two bees are domesticated (*A. cerana indica* and *A. mellifera*). But according to recent research *Apis trigona* is also being domesticated.

3). While putting bee frame we should be careful that not a single bee should be pressed underneath the frame or else they may get aggressive and attack us.

4). Use of suit, veil, and any other necessary protective gear bear opening bee hive.



**ON JOB TRAINING PROGRAM IN COMMERCIAL BEEKEEPING
ORGANIZED BY**

AQUA SOIL PVT. LTD., HISLOP COLLEGE AND SINDHU MAHAVIDYALAYA

Name of the Participant: **Aanchal . Arvind . Sharma**
Handling and examination of colony

Day	Colony number	Total number of bee frames	Bee strength (number of combs)	Brood area		Food stored			Egg laying (yes/no)	Queen bee (yes/no)	Symptoms of bee disease	Attack of bee enemies	Space sufficient or less
				Worker brood	Drone brood	Scaled	Honey (unripe)	pollen					
1	2	8	2	yes	yes	yes	yes	yes	yes	yes	no	no	less
2	5	6	6	yes	no	no	poor	yes	yes	yes	yes	yes	sufficient
3	1	8	8	yes	yes	no	yes	yes	yes	yes	no	no	sufficient
4													
5													

[Signature]
03/04/24
Signature of Instructor

[Signature]
04/04/24
Signature of Instructor

[Signature]
05/04/24
Signature of Instructor

Signature of Instructor

Signature of Instructor

Day 2

On day 2 we have done morphometry of various bee species such as *Apis mellifera*, *Apis dorsata*, *Apis cerana indica*, *Apis florea*. This was done in the guidance of Mamta Mann.

MORPHOMETRY

Morphometry, this term is derived from the Greek words "morpho" meaning "shape" or "form" and "metria" meaning "measurement". Morphometry means the quantitative analysis of form, which includes both size and shape.

MORPHOLOGY OF HONEYBEES -

The morphology of honey bees refers to their physical characteristics and body structures.

1. HEAD - Triangular in shape, the head has five eyes, a pair of antennae, and mouth parts consisting of two mandibles, the proboscis, etc.

a) **Eyes** - Bees have pair of compound eyes and three small simple eyes called as ocelli.

b) **Antennae** - Antennae are a pair of sensitive receptors. The antennae's functions are to feel or touch and to smell and thus to guide the bee outside and inside the hive, to differentiate floral and pheromone odours, and to locate hive intruders.

c) **Mandibles** - Mandibles are a pair of jaws suspended from the head and parts of the bee's mouth. The bees use them to chew wood when redesigning the hive entrance, to chew pollen and to work wax for comb-building. They also permit any activity requiring a pair of grasping instruments.

d) **Proboscis** - In honeybees proboscis is not a permanent functional organ. It is improvised temporarily to produce a unique tube for drawing up liquids such as sweet juices, nectar, water and honey. The insect releases it when needed for use, then withdraws and folds it back beneath the head when it is not needed.

2. THE THORAX - The thorax supports two pairs of wings and three pairs of legs and the muscles that control the movement of the head, abdomen and the wings.

a). **Wings** - The wings of the honeybee are thin, flat and two-layered. The front pair is much longer than the rear. Pterostigma is heavier section of wing than nearby sections and it assists in gliding.

b). **Legs** - Each pair of legs differs in size and shape from the other two pairs and is jointed into six segments. Its primary function is to help the bee to walk and run.

PRESERVATION OF BEE SPECIMENS SPECIMEN

1. Collecting – The bee is collected and pinned as soon as possible after the death while the body is still flexible.

2). Positioning – The bee is positioned on its back. Care should be taken to ensure that the antennae are not folded or torn.

3). Labelling - Properly label the specimen with essential information such as the date, location of collection, collector's name, and species name. This information is crucial for scientific documentation.

4). Preservation - There are different methods for preserving bee specimens, depending on the intended use and long-term storage needs:

- Dry Preservation
- Wet Preservation (Ethanol) .
- Slide Mounting.

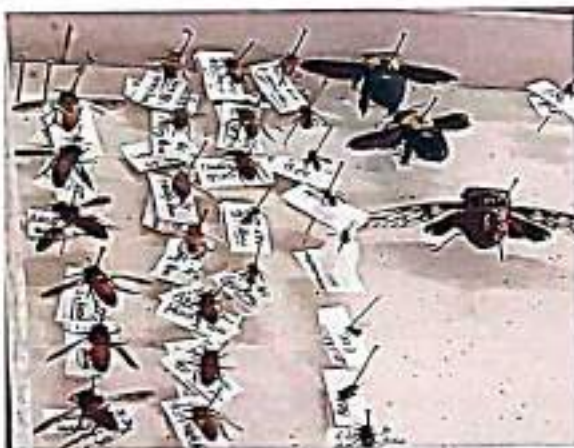

EXTRACTION OF BEE STING FROM ITS ABDOMEN

1. Sting is present in queen bee and worker bees, whereas it is absent in drone. Sting is present in worker bees for protection of hive from enemies. In case of queen bee, she uses sting to fight with her rival queen.
2. This activity of sting extraction was performed in group involving five students. Each student was able to extract the sting from bees abdomen.
- 3). We selected worker bees of species *Apis cerena indica* for the sting extraction.



- 4). Using forceps, we removed the sting from the abdomen of the selected worker bees.
- 5). The extracted stings were stored in vials filled with alcohol along with the selected bee species.

These parts work together to create a safe and productive environment for the bees. The brood chamber (deep boxes with frames for raising brood) is usually at the bottom, while the honey supers (medium or shallow boxes for honey storage) are on top. Beekeepers manage these parts to ensure the health of the hive and to

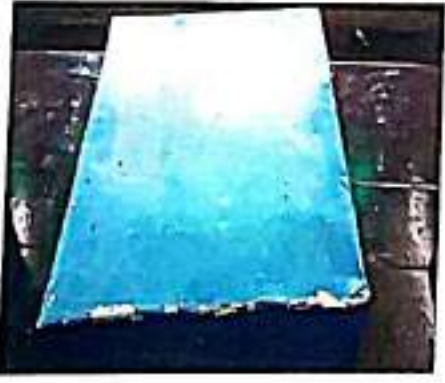

Environment - Providing a variety of flowering plants nearby can attract solitary bees to the area.

4. Maintenance

Cleaning - Bee hotels should be cleaned annually, typically in late fall or early spring, to remove debris and pests. Cleaning involves removing the nesting material from the tubes, gently scrubbing with a brush, and allowing them to dry before replacing.

Replacing Tubes - Over time, the tubes may become worn or harbor pests, so they may need to be replaced periodically.

Monitoring - Regular monitoring can help ensure that the bee hotel remains healthy and active.

By providing a bee hotel in your garden or outdoor space, you can help support local pollinator populations, improve pollination of nearby plants, and contribute to biodiversity. It's a simple and effective way to make a positive impact on the



**ON JOB TRAINING PROGRAM IN COMMERCIAL BEEKEEPING
ORGANIZED BY**

AQUA SOIL PVT. LTD., HISLOP COLLEGE AND SINDHU MAHAVIDYALAYA

Measure and record dimension of the various Apiary parts in the given blanks

Name of the Participant: **hondhal. A. Sharma**

Sr. No	hive Parts	Radius	Measurement and dimension	Drawings
1	Bottom floor board	36.4 x 30.1 x 4.2		34.5 x 26.7 x 1
2	Alighting board			
3	Entrance	26.4 x 24.4 x 2.2		
4	Brood Chamber	20.8 x 28.8 x 11.4		23.5 x 26.4 x 11.2
5	Frame	26.3 x 11 x 16.6		
i	Top bar	26.2 x 2.9 x 1		
ii	Side bar	9.2 x 8.0 x 1 (Top)	12.0 x 2.5 (Bottom)	
iii	Bottom bar	22.0 x 2.5 x 1		
6	Dummy board			
7	Inner/Crown Cover	28.3 x 30.5 x 2.1		25.9 x 23.4
8	Top Cover	35.1 x 33.9 x 8.2		27.6 x 26.6 x 3.8
9	Super chamber	30.4 x 28.9 x 9.3		26.7 x 25 x 1
10	Any other			

Super Frame
 Top Base → 26.4 x 2.2 x 1
 Side Base → (Top) 4 x 3 x 1
 Bottom Base → 22.1 x 2.4 x 1

(bottom) → 4.6 x 2.4 x 1.

 Signature of Instructor

Day 5

COLONY DIVISION

THE PROCESS OF COLONY DIVISION –

Have necessary equipment ready such as bee veils, hive boxes, frames, lids, bottom boards. Choose the hive that will remain in its original location (the parent hive). Move frames containing brood, eggs, pollen, and honey to a new hive box (the split hive). Ensure the split hive has enough resources to build up into a viable colony. If the split hive does not have a queen or needs a new one, introduce a mated queen or queen cell. Ensure both hives have enough resources, balance frames with brood, honey, and pollen between the parent and split hives. Close the parent hive with a cover and ensure the entrance is open. Close the split hive and move it to a new location if desired. Regularly check both hives to ensure the split hive is building up and the parent hive is not becoming overcrowded.

Colony division is an important beekeeping technique that allows beekeepers to manage their colonies effectively, prevent swarming, and increase the number of hives for various purposes.



Day 6

Familiarization With Bee Flora

- 1). *Zizipus Jujube* – Also known as Jujube fruit tree and is native to India. This tree is known to have a variety of traditional and medicinal uses, especially bees.
- 2) *Azadirachta indica* – Commonly known as Neem tree and is native to India. The tree produces large. They are usually attracted by the abundant nectar and pollen.
- 3) *Psidium guajava*– Commonly known as guava tree is a species native to Indian subcontinent. This tree produces small, white, five plated flower. The leaves are tricalporate.
- 4). *Tamarindus indica* – Also goes by the name of Emli, found in tropical and subtropical regions around the world. This plant produces small, Red & yellow Elagated flowers in colour.
- 5). *Mangifera indica* – commonly known as mango tree is native to Indian subcontinent. Leaves are compound with several leaflets arranged along a central stalk. The leaves on the tree show spreading pattern.
- 6). *Terminalia arjuna* – its vibrant flowers are actually modified leaves called Arjun tree. These bracts come in various colours, including shades of sessile and occur in simple or paniced spikes.
- 7). *Carica papaya* – Commonly known as Papita tree is native to India. Its flower have five petals, with one of them often being a darker or contrasting colour.
- 8). *Phyllanthus emblica* – Commonly known as Amla tree, round in shape. The tree produces small flowers that are greenish-yellow in colour.
- 9). *Brassica oleracea*- It is commonly known as wild cabbage. Its one of the most diverse vegetables including cabbage and savoy, kale, broccoli,cauliflower, brussels sprout, kohlrabi, and some ornamental forms.
- 10). *Java Plum* – This tree is commonly known a Jamun tree. The pulp of the fruit is grey to pink in colour, and has a seed in the centre.

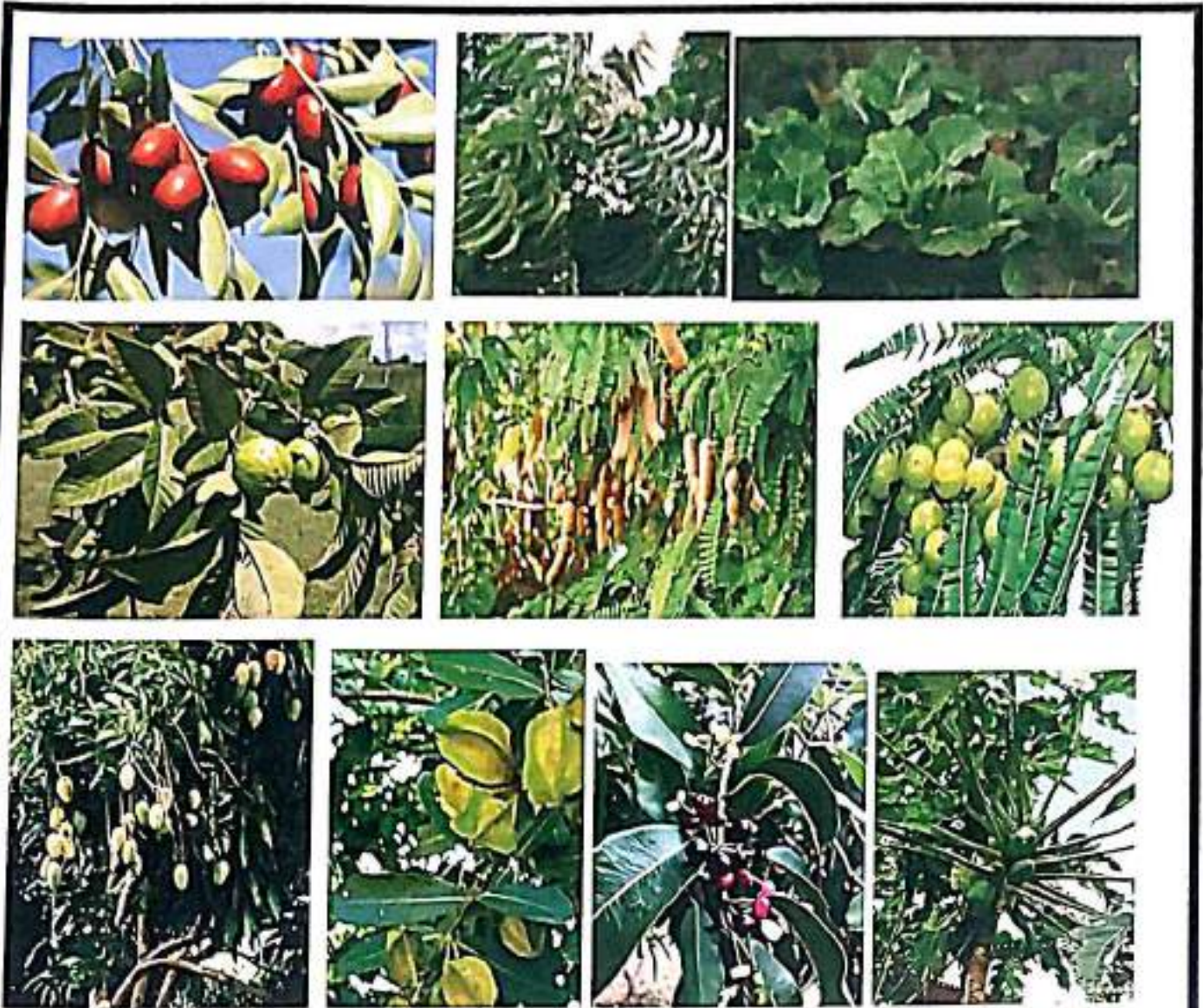

Table : Floral characters of - *Jana plum* (Jamun)

Floral Characters	Observations
Flowering period	March- April
Flower type	Small, white flowers
Odour and nectar	Strong aroma
Flower opening time	Early morning
Mode of anther dehiscence	longitudinal dehiscence
Pollen production/flower	ample pollen and flower production.
Pollen aperture type	Colpate aperture
Stigma type	lobed or divided.

Table : Flower visitors of - *Jana plum* (Jamun)

Floral visitor	Duration of visit	Mean abundance (%)	Forage type
<i>Apis dorsata</i>	few seconds to several minutes		Pollen and Nectar
<i>Apis cerana indica</i>			Nectar and Pollen
<i>Apis florea</i>			Nectar and Pollen
Stingless Bee			Nectar and Pollen

Signature of Instructor

Table : Floral characters of -- *Tamarindus indica*

Floral Characters	Observations
Flowering period	April - July
Flower type	Small, yellowish, dense clustered flowers.
Odour and nectar	Very mild odour, nectar production not abundant
Flower opening time	Morning
Mode of anther dehiscence	Longitudinal dehiscence.
Pollen production flower	Moderate to high number of flower production
Pollen aperture type	Colpate
Stigma type	lobed or divided.

Table : Flower visitors of - *Tamarindus indica*

Floral visitor	Duration of visit	Mean abundance (%)	Forage type
<i>Apis dorsata</i>	few seconds to several minutes		Nectar and pollen
<i>Apis cerana indica</i>	few seconds to several minutes		Nectar and pollen
<i>Apis florea</i>			
Stingless Bee	few seconds to several minutes		Nectar and pollen.

Signature of Instructor

Day 8

CONCLUSION

In this APICULTURE industrial training program, I encountered a plethora of novel concepts and acquired a multitude of skills in context to honeybees. By observing the colonies of bee for eight continuous days I was able to learn the properties, different behaviours, diversity and their nature of living. During morphometry we extracted the bee sting, measured body parts of *Apis cerana indica* and also did the bee box measurement. To learn the properties of honey that is formed in a hive by honeybees, we studied the different flora in that region..

We attended different lectures delivered by guests, from which we got to know about different job opportunities in government and private sector, Migration patterns of Honeybees, factors responsible for bee migration, extraction procedures, honey marketing, how to apply foundation sheet in bee frame, queen cell cup formation, Apitherapy, honey products. Lastly we were assigned with creating a bee hotel specifically designed to accommodate solitary honeybees, a subject that aligns perfectly with my keen interest in this field. Overall, this On Job Training helped me to enhance my basic knowledge of honeybees.

**Shri Shivaji Education Society Amravati's
Science College, Congress Nagar, Nagpur
Department of Zoology**

On Jon Training submission M.Sc. Zoology (Semester II) 2023-2024

SR. NO.	NAME
1	Aanchal Arvind Sharma
2	Aniket Sevakram Khordage
3	Durga Arvind Wasnik
4	Gunjan Prakash Sherkar
5	Nikita Pandhari Dhole
6	Payal Ramprasad Kodwate
7	Piyush Premdas Kale
8	Pradhnya Chandrabhan Wasnik
9	Ritika Manohar Tandekar
10	Ruchi Netranand Kale
11	Payal Patankar
12	Shreya Pramod Urkede
13	Simran Mahendra Sukheja
14	Surbhi Gajanand Kakde
15	Vishaka Shrikant Bante
16	Tanisha Mahendra Sukheja
17	Sushani Naidu
18	Astha Badade

Dr. A. A. Helder
Coordinator, IQAC
Science College,
Congress Nagar, Nagpur

Prof. M. P. Dhore
Principal
Science College,
Congress Nagar, Nagpur



ON JOB TRAINING (OJT) REPORT

ORGANO MUSHROOM TRAINING CENTER,

NAGPUR

Submitted in partial fulfilment of

DEGREE OF MASTER OF SCIENCE (BOTANY)

In the Faculty of Science

Submitted By

MS. RAJSHREE P. KOWE .

M. Sc.-I (Botany)

(Semester-II)



DEPARTMENT OF BOTANY

S.S.E.S. AMRAVATI'S SCIENCE COLLEGE

Congress Nagar, Nagpur

2023-2024

CERTIFICATE

This is to certify that **Ms. Rajshree P. Kowe** student of M. Sc. (Botany) Semester-II, Department of Botany, **S.S.E.S AMRAVATI'S SCIENCE COLLEGE, CONGRESS NAGAR, NAGPUR** has successfully completed a period of On-Job Training (OJT) at **ORGANO MUSHROOM TRAINING CENTER NAGPUR** in the session 2023-2024 prescribed as per R. T. M Nagpur University Syllabus. She has completed all the requirements of the course.



Dr. R.H. Mahakhode

Signature of Teacher Coordinator

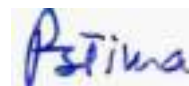

Dr. P.S. Tiwari

HEAD
DEPARTMENT OF BOTANY
SHRI SHIVAJI EDUCATION SOCIETY
AMRAVATI'S SCIENCE COLLEGE
CONGRESS NAGAR, NAGPUR

DECLARATION

This On Job Training Project Report written and submitted by **Ms. Rajshree P. Kowe** is my original work and has not been submitted earlier to any other college or institution for the fulfilment of the course of study. The findings of the study are based on the work done and information collected by me during my On Job Training in **ORGANO MUSHROOM TRAINING CENTER, NAGPUR.**



(**Ms. Rajshree P. Kowe**)

ACKNOWLEDGEMENT

I would like to express my sincere gratitude to Dr. Priya A. Bavaskar, Director, Organo Mushroom Training Center, Nagpur, for providing me with the opportunity to undergo my On Job Training (OJT) at their esteemed Organo Mushroom Farm. I extend my heartfelt thanks to the entire staff of Organo Mushroom Training Center , Nagpur for their guidance, support, and expertise throughout my training period. I am also thankful to **Prof. M.P. Dhore, Principal, SHRI. SHIVAJI SCIENCE COLLEGE, CONGRESS NAGAR, NAGPUR, Prof. P.S. Tiwari, Head, Department of Botany, and Dr. R. H. Mahakhode, Coordinator, and the entire staff of the Department of Botany, Shri Shivaji Science College, Congress Nagar, Nagpur,** for their cooperation and encouragement, which greatly contributed to my learning experience.

With deepest gratitude and appreciation, I humbly give thanks to the people who, with all they can, helped me in making my on job training (OJT) a possible one. I am truly grateful for the hands-on training and practical skills that I have acquired, which will undoubtedly benefit me in my future endeavors. Thank you for making my OJT experience at **Organo Mushroom Training Center, Nagpur,** a rewarding and Knowledgeable.



(Ms. Rajshree P. Kowe)

INDEX

Sr. No.	Contents	Page No.
1.	Introduction	6
1.1.	Importance of OJT	6
2.	Objectives	7
3.	Introduction of Mushroom	8
4.	Types of Mushroom	8
5.	Mushroom Cultivation process	13
6.	Benefits of Mushroom	24
7.	Market Potential and Opportunities	26
8.	Conclusion	27

1. Introduction

On-the-Job Training: (OJT) is a hands-on method of teaching the skills, knowledge, and competencies needed for employees to perform a specific job within the actual work environment. This approach to training is practical and direct, offering realworld experience under the supervision and guidance of experienced professionals .

1.1. Importance of OJT:

1)Practical Experience :

OJT provides hands-on experience, allowing trainees to apply theoretical knowledge in real-world situations. This practical exposure is essential for skill development and confidence building.

2)Adaptability :

Learning in the actual work environment helps trainees adapt quickly to the specific demands and nuances of the job, making them more effective and efficient.

3)Enhanced Learning:

The interactive nature of OJT makes learning more engaging and effective compared to traditional classroom settings, leading to better retention of knowledge.

4) Knowledge Transfer :

OJT facilitates the transfer of institutional knowledge from experienced employees to new hires, preserving valuable expertise and maintaining continuity within the organiz

5) Business Insights:

Training on the job provides insights into the business side of mushroom cultivation, including cost management, marketing, and cust

6) Real-Time Feedback:

Trainees receive immediate feedback, allowing them to correct mistakes and improve performance quickly.

2. Objectives

1. Understand Mushroom Biology:

- Learn the life cycle and types of mushrooms.

2. Develop Cultivation Skills:

- Master substrate preparation, sterilization, and inoculation.
- Control environmental conditions for optimal growth.

3. Harvesting and Quality Control:

- Practice effective harvesting and storage methods.
- Ensure quality control and comply with safety standards.

4. Pest and Disease Management:

- Identify and manage common pests and diseases.

5. Sustainability Practices:

- Utilize agricultural waste for substrates.
- Implement eco-friendly cultivation methods.

6. Business and Marketing:

- Understand economic aspects and market trends.
- Develop marketing and sales skills.

7. Health and Safety:

- Follow health and safety protocols to prevent accidents.

8. Teamwork and Communication:

- Enhance communication and teamwork.
- Develop leadership and training skills.

By achieving these objectives, trainees will be well-prepared for successful mushroom cultivation and farm management.

3. Introduction of mushroom

Man's interest in fungi started with the observation of the beautiful, umbrella shaped mushrooms and toad stools growing on soils forming fairy rings. The fungi (sing., fungus) are a distinct group of organisms that belong to lower plants. The name of the fungi derived from the most obvious representatives, the mushrooms (Greek- mykes, Latin- fungus). Mushrooms are fleshy fruiting bodies of microorganisms called fungi arising from a group of mycelia buried in substratum basically any organic matter.

Mushrooms are a group of fleshy macroscopic fungi. They lack chlorophyll having heterotrophic mode of nutrition. They synthesize enzymes like cellulose and hemicellulose which bring the substrate to available forms. Mushrooms live on dead matter as they are saprophytes.

Chang and Miles (1992) gave the definition that is now universally accepted. They defined mushroom as a "macro fungus with a distinctive fruiting body which can be either epigeous or hypogenous and large enough to be seen with the naked eye and can be picked with hand."

4. Types of mushroom

1. White Button Mushroom

Scientific name: *Agaricus bisporus*

Color : When young and fresh, their cap is smooth and white, while the stem is also white and slender. As they mature, the cap may develop slightly brown or tan hues, but they maintain an overall pale appearance.

Texture : These mushrooms have a smooth, slightly glossy cap and a tender yet firm texture.

Button mushroom is a celebrity in the edible mushroom world. It is widely cultivated in India. It is also regarded as one of the best mushroom in India in health as well as in the economic aspect. These are the most commercially cultivated and commercially used mushrooms.

They have become an attractive ingredient in many cuisines due to their ability to integrate health and taste together.

Cultivation:

Optimum temperature requirement for spawn running ,20-28°C Vegetative growth and 12-18°C for reproductive growth. Relative humidity is requirement is 80-90% .



1. White Button Mushroom

2. Oyster Mushroom

Scientific name: *Pleurotus spp.*

These include mushrooms belonging to the *Pleurotus* genera, referred to as Oyster Mushrooms due to their structural resemblance to a beautiful oyster shell. They are a significant mushroom variety in India. They are also known to possess an oyster-like flavor. They come in different colors like grey, white, brown, pink, and yellow. They have a fan-shaped structure with a velvety texture and produce a delicate aroma during cooking.

In India, *Pleurotus ostreatus*, referred to as Dhingri, is a type of edible mushroom cultivated in India and is also regarded as one of the best mushroom in India. Their luscious flavor makes them a favorite constituent in various cuisines and also a favorite among vegetarians.

There are actually over 200 species of *Pleurotus*, but these popular varieties are most likely to be cultivated and sold.

- 1) Golden Oyster
 - 2) Pink Oyster
 - 3) Blue Oyster
 - 4) King Oyster
 - 5) Elm Oyster
 - 6) Pearl Oyster
 - 7) Phoenix Oyster
- Optimum temperature requirement for spawn running is 20 to 30°C
Relative Humidity require 55 -70% in Oyster Mushroom.



2. Oyster Mushroom

3. Paddy Straw Mushrooms.

Scientific name : *Volvariella volvacea*

Commonly known as the straw mushroom, or the Chinese mushroom,

It is an edible mushroom of tropics and subtropics, and first cultivated in China in 1822 . It is one of the easiest mushrooms to cultivate. Paddy straw mushrooms ,were first cultivated in India in the year 1940. It is equally popular as white button mushroom for its flavour, aroma, delicacy and nutrients. These straw mushrooms are cold and good for the summer season.

Appearance : They typically have a small, oval cap that is light to dark brown, and they are often harvested before the cap opens fully, giving them a distinctive egg-like shape.

Cultivation : Paddy straw mushrooms are usually grown on substrates of paddy straw, banana leaves, or other agricultural waste products. They thrive in warm, humid conditions.



3. Paddy Straw Mushroom

4. Reishi mushrooms

scientifically known as *Ganoderma lucidum*, are renowned in traditional medicine, particularly in East Asian cultures, for their potential health benefits. Also known as lingzhi in Chinese, these mushrooms are characterized by their tough, woody texture and distinctive kidney-shaped cap with a reddish-brown varnished appearance .

Appearance : They have a shiny, varnished look with colors ranging from reddishbrown to black. The fruiting body is tough and woody.

Cultivation : Reishi mushrooms grow on decaying hardwood trees and logs, especially in warm and humid environments. They can also be cultivated on various substrates such as sawdust and wood chips.



4. Reishi Mushroom

5. Milky mushrooms

Scientifically known as *Calocybe indica* are a type of edible mushroom popular in tropical and subtropical regions, particularly in India. They are named for their milky white color and are valued for their nutritional benefits

Appearance : Milky mushrooms have a robust, thick stalk and a large, white to offwhite cap that is convex to flat as it matures. The gills underneath the cap are white and crowded.

Cultivation : Milky mushrooms are well-suited for cultivation in warm, humid climates. They are typically grown on substrates such as straw, sawdust.



5. Milky Mushroom

5. Mushroom Cultivation Process

1. Selection of Mushroom Species

For Mushroom Cultivation we have chosen Oyster Mushroom Species *Pleurotus florida*. Most of the species of Oyster Mushroom have very wide temperature, relatively humidity, fast growing and adaptability of various substrates.

2. Preparation of mother spawn :

For 2 hours, wheat grains are soaked in water. Dead seeds should be removed. The grains are then washed again and boiled in water for at least 10-15 minutes. After that, the grain is allowed to cool and air dried mixed with calcium carbonate powder at 2 -5% The grains are then loosely packed in bottles that are only two-thirds full. cotton wool is used to plug these, the grain is sterilized in Autoclave or pressure cooker for about 1 hour at 121°C.





3. Preparation of Substrate :

A Common substrate for Oyster Mushroom is wheat, rice or barley straw and hardwood sawdust , vegetable plant residues etc. Paddy straw is widely used ,it is easily available and cheap.

Cut straw into small pieces , about 3-5 cm long this increase a surface area and makes it's easier for mycelium to grow and soak in fresh water 8 -16 hours. Excess water from straw is drained off by spreading it on filter paper.



Latitude: 21.128184
Longitude: 79.081803
Elevation: 334.46±2 m
Accuracy: 20.0 m
Time: 02-04-2024 15:03
Note: Mushroom cultivation



4. Inoculation

- ❖ When Substrate to cool down at room temperature it is ready for filling and spawning at this stage moisture content of substrate is 70%.
- ❖ Polythene bags (35×50 cm) are used for cultivation . 100 g of spawn can be used for 1 bag
- ❖ Layering:
Spread the prepared substrate in bag to depth of about 4 -6 inches
- ❖ Mixing of Spawn:
Gently mix the spawns into the top of substrate ,this can be done using clean hands or sterile tools.

- ❖ Spawns is evenly distributed throughout this top layer , similarly 2nd ,3rd and 4th layer of substrate are put simultaneously . After spawning the bags are tied with help of rubber bands.
- ❖ Simply cut 2-3 cm small holes in bags for optimal air access. Surface of each is covered with cotton to ensure optimal mycelium growing condition and reduce contamination.







5. Incubation Period

The incubation period is a critical phase in mushroom cultivation, during which the mycelium (the vegetative part of the fungus) colonizes the substrate. Proper management of the incubation period ensures healthy mycelium growth, setting the stage for successful fruiting.

Darkness : Most mushroom species require darkness during the incubation period to promote mycelial growth. Avoid exposing the substrate to light.

Temperature : Maintain an optimal temperature range specific to the mushroom species you are cultivating ,Oyster Mushrooms (*Pleurotus* spp.): 21-27°C (70-81°F).

Humidity : Keep the humidity high, around 90%, to prevent the substrate from drying out.

Ventilation : Ensure proper air circulation to avoid the buildup of carbon dioxide. Stale air can hinder mycelium growth and increase the risk of contamination.

Monitoring : Regularly check for signs of contamination and ensure the environment remains within the required parameters for mycelium growth. Incubation Period Of Oyster Mushroom is 1 to 3 Weeks.



6. Fruiting

1. Initiation

Initiation is the link between mycelial growth and mushroom formation. This is the time when the substrate is fully colonized and maybe even showing signs of pinning. This stage involves the formation of tiny mushroom buds or "Pins"

2. Pinning

- ❖ Small, pin - like structure appears on the surface of the substrate. Pins grow from a few millimeters to about 1-2 cm. Maintain High humidity (85-95%) and Adequate fresh air exchange to prevent the pinhead's from drying out or elongation excessively.





3. Mature Fruiting Bodies

- ❖ The stem grow longer and caps start to enlarge.
- ❖ In oyster mushrooms the gills are fully formed and often exposed.
- ❖ The cap has fully expanded .





7. Harvesting

The fruit bodies should be harvested before spore release.

Grip : Gently hold the base of the mushroom cluster where it attaches to the substrate.

Twist : Twist the cluster slightly to loosen it from the substrate.

Pull : Carefully pull the cluster away from the substrate. This method is suitable for larger clusters.

Cutting Method:

Knife/ Scissors: Use a sharp, clean knife or pair of scissors.

Cut : Cut the stem of the cluster at the base, as close to the substrate as possible. This method is more precise and can be better for smaller or more delicate cluster.



8. Environmental Requirements for Cultivation

- 1) **Temperature:** Temperature affects the growth rates of mushrooms, influencing both mycelium colonization and fruiting body development.
- 2) **Humidity:** Humidity (85-95%) is essential for mushroom fruiting bodies to develop. Low humidity can cause drying out and poor mushroom quality, while excessively high humidity can lead to diseases and contamination.
- 3) **Light :** While some mushrooms, like button mushrooms, can grow in complete darkness, others, such as oyster mushrooms (*Pleurotus* spp.), require some light for proper development. Light intensity and duration should be managed according to the species' requirements.
- 4) **Air Quality:** Proper ventilation is crucial to prevent the build-up of carbon dioxide (CO₂) and to supply fresh oxygen (O₂). High CO₂ levels can inhibit mushroom development and lead to abnormal growth.
- 5) **pH Levels :** The pH of the substrate should be within an optimal range for the specific mushroom species. For example, oyster mushrooms prefer a pH of 6

6. Benefits of Mushroom

1) Nutritional Benefits

- **Low in Calories :** Ideal for weight management.
- **Rich in Nutrients :** Provide B vitamins, selenium, copper, and vitamin D.
- **High in Antioxidants:** Protect cells from damage and boost immune function.
- **Good Source of Fiber:** Supports digestive health.
- **Contains Beta-Glucans :** Enhances immune function and heart health.
- **Low in Fat and Cholesterol :** Promotes heart health.

- **Potential Anti-Inflammatory Properties :** May help reduce inflammation in the body: Promotes heart health.

2) Medicinal Benefits

- **Immune System Support:** Certain mushrooms like reishi, shiitake, and maitake are known for their immune-boosting properties, helping to enhance the body's defense mechanisms.
- **Anti-Inflammatory Properties:** Mushrooms contain compounds that have antiinflammatory effects, which can help reduce inflammation in the body.
- **Anticancer Properties:** Some mushrooms, such as turkey tail and maitake, have been studied for their potential anticancer properties due to their polysaccharide content.
- **Brain Health:** Certain mushrooms like lion's mane have been linked to cognitive benefits, including the potential to improve memory and stimulate nerve growth.

3) Economical Benefits

- **Sustainable Farming:** Mushrooms can be cultivated using agricultural waste products, making them a sustainable option for farmers.
- **Income Generation:** Mushroom farming can be a profitable venture due to their high market demand and relatively low production costs.
- **Job Creation:** The mushroom industry supports a variety of jobs, from farming and harvesting to processing and sales.
- **Value-Added Products:** Mushrooms can be processed into a variety of products, including dried mushrooms, supplements, and extracts, increasing their economic value.

4) Environmental Benefits

- **Biodegradation:** Mushrooms play a crucial role in breaking down organic matter, contributing to nutrient cycling and soil health.

- **Carbon Sequestration:** Fungi, including mushrooms, help sequester carbon in the soil, contributing to carbon storage and mitigating climate change.
- **Reduced Agricultural Waste:** Mushrooms can be grown on organic waste materials such as straw, sawdust, and agricultural by-products, reducing waste and promoting recycling.
- **Mycoremediation:** Certain mushrooms can absorb and break down pollutants in the environment, including heavy metals and pesticides, thereby cleaning up contaminated soil and water.

Mushrooms offer a wide range of benefits across multiple domains, making them a valuable addition to diets, medicine, economies, and the environment.

7. Market Potential and Opportunities

Mushroom cultivation offers several market opportunities due to its growing popularity for both culinary and medicinal uses.

- **Mushroom Snacks Types :** Chips, jerky.
Benefits : High in protein, low in calories, vegan.
- **Mushroom-Infused BeveragesTypes :** Coffee, tea, hot chocolate Benefits :
Enhanced focus, immune support.
- **Mushroom Supplements Forms :** Capsules, powders, extracts.
Market : Health and wellness sector.
Benefits : Immune boosting, stress reduction, cognitive enhancement.
- **Soil Improvement :** Organic matter addition, soil structure improvement.
Benefits : Increases soil fertility, enhances water retention, reduces soil erosion.
Fungal Biopesticides Types : Beauveria bassiana, Metarhizium anisopliae.
Benefits : Natural pest control, reduces chemical pesticide use, safe for nontarget species.
- **Local and Community-Based MarketsFocus :** Supporting local economies, reducing carbon footprint.
Benefits: Fresher produce, stronger community ties.

Opportunity : Promote local and regional sales to environmentally conscious consumers.

8. Conclusion

Mushroom cultivation presents a robust opportunity for entrepreneurial ventures due to its versatile applications and growing market demand. By focusing on gourmet and medicinal mushrooms, cultivators can cater to high-value markets that prioritize health and sustainability. Exploring diverse mushroom-based products, from snacks to bioplastics, opens additional revenue streams and meets consumer demand for innovative and eco-friendly products. Agricultural and environmental applications of mushrooms, such as mycoremediation and organic farming practices, contribute to sustainable development and environmental conservation. The organic and sustainable market segment continues to expand, driven by consumer awareness and preferences for health-conscious and eco-friendly options. Export opportunities offer significant potential, especially in markets with high demand for specialty and organic mushrooms, supported by advancements in logistics and favorable trade agreements. In conclusion, mushroom cultivation is a dynamic and promising field with diverse market opportunities.





CERTIFICATE

This is to certify that
Mr./Ms./Mrs. Rajshree P. Kowe
has worked as an-job trainee entitled
"Hands on training on Mushroom Cultivation"
in this organization under the supervision of
Mrs. Priya Anilkumar Bavaskar
from 11 March 2024 to 4 April 2024. He/She worked
for not less than 120 hours during this tenure.



Priya Anilkumar Bavaskar
Director
Mrs. Priya Anilkumar Bavaskar
Organic Mushroom Nigam



Latitude: 21.086986
Longitude: 79.069089
Altitude: 258.2±2 m
Accuracy: 6.4 m
Time: 06-04-2024 13:49
Note: Mushroom cultivation

THANK YOU!

M.Sc-Botany Students Participated In Hands on Training In
Mushroom Cultivation Under On Job Training (OJT)

Date:-11th March 2024 TO 4th April 2024

Sr.No		Name Of The Students
1	Ku	Aishwarya P. Bambal
2	Ku	Megha S. Bangadkar
3	Ku	Dipali C. Bisen
4	Ku	Anushree V. Chirkute
5	Ku	Ekta L. Jadhav
6	Mr.	Chetan S. Kolhe
7	Ku	Rajshree P. Kowe
8	Ku	Chaitali S. Patil
9	Mr.	Jiwak D. Wasekar
10	Ku	Akanksha L. Wasnik

Coordinator (OJT)

Dr.R.H.Mahakhode

Prof. & Head

Dr.P.S.Tiwari

Professor and Head
Department of Botany,
SSES Am's Science College
Congress Nagar, Nagpur-12

Shri Shivaji Education Society Amaravati's

Shivaji Science College

Congress Nagar, Nagpur – 440012



DEPARTMENT OF MATHEMATICS

A Report on

“MATLAB”

As a part of Job Training

Submitted By

PRERANA GHARDE

(MSc Semester-II)

2023-24



Certificate of OJT

This certificate goes to

Prerana Gharde

in appreciation of your successful completion of

On Job Training on "MATLAB"

from 15 Feb 2024 to 05 March 2024



Sandeep Sonaskar

Sandeep Sonaskar
Director



UDYAM-MH-20-0105097

Cert. Num VSI02024/02/315

CERTIFICATE

This is to certify that dissertation entitled "MATLAB" Submitted by "Prerana Gharde" in partial fulfilment of the requirement of the degree of Master of Science in Mathematics, S.S.E.S Amt's Science Collage, Nagpur, RTM Nagpur University, Nagpur.

This work was carried out manner in excellent by "Prerana Gharde" under the supervision of "Mr. Sandeep Sonaskar" of V S Informatics Private Limited During the academic year 2023-2024.

Date:-

Place:- Nagpur

Mr. Sandeep Sonaskar

External Mentor

V S Informatics

Private Limited

CERTIFICATE

This is to certify that Report on "MATLAB" Submitted by " Prerana Gharde " in partial fulfilment of the requirement of the degree of Master of Science in Chemistry, S.S.E.S Amt's Science Collage, Nagpur, RTM Nagpur University, Nagpur. This work was carried out manner in excellent by " Prerana Gharde " under the supervision of "Dr. VIDYA CHAVHAN" Assistant professor of Shivaji Science College, Nagpur. During the academic year 2023-2024.

Date:-

Place:- Nagpur

Swamdukar
19/06/2024

Dr. VIDYA CHAVHAN

Internal Mentor

Department of mathematics,

S.S.E.S Amt's science College,

Nagpur.

Prof. KALPANA PAWAR

Head and Professor

Department of mathematics,

S.S.E.S Amt's science College,

Nagpur.

External/
(Dr. S.W. Jamburkar)

INTRODUCTION

VS Information Pvt Ltd Established in 2010 under Govt Company Act 1956 (CIN: U72900MH2010PTC205754) works in cloud server hosting, call centre dialer, asterisk based communication, Research & Development in IoT & IIoT. With vision to provide technology & solution for customers with reliable, affordable and quality service.

- Embedded & IOT Product Design.
- Automation Industry Services.
- Educational Trainer Kits
- Technology Services

PRODUCTS

VS IPL deals in the various research design and development services like electric vehicle conversion kit, LiPO battery manufacturing, Embedded IoT Trainer kit

Embedded & IOT Product Design

We provide product development circuits in embedded and IoT like Home and Industry automation switches and monitoring system

Automation Industry Services

PLC, HMI, Conveyor belt mechanism and all types of Industry Automation services

Educational Products

Learning the technology by young scientists VS IPL developed Microcontroller Programming Test Bench, Robotics Kits, IoT test bench kits

Technology Products

Electric Vehicle conversion kit and dealership, PCB Design and IoT cloud services

INTRODUCTON

Science College, Congress Nagar, Nagpur, is one of the 303 institutions run by Shri Shivaji Education Society, Amravati is a premier institution of higher learning in Central India affiliated to R.T.M. Nagpur University, Nagpur.

Tamso Ma Jyotirgmaya (To lead from darkness to light) is the mission of the institution. National Assessment and Accreditation Council (NAAC) accredited the college with Five Star level in the year 2002, re-accredited with CGPA of 3.51 on four-point scale at A+ grade in June 2017 and identified by UGC as College with Potential for Excellence. The College is an institutional member of Asia Pacific Quality Network (APQN).

With its competent galaxy of faculty members, the college has been rendering sincere services in the field of higher education since 1967. This is a single faculty college with a variety of courses both at 10+2 stage and degree level and offers PG courses with recognized centres of Higher Learning and Research in Microbiology, Chemistry, Computer Science, Physics, Mathematics, Zoology and Botany.

VISION & MISSION

To Create human resources through quality, societal, progressive and affordable education.

To provide students with an environment for all round development of their intellectual, physical, aesthetic and social potentials. To discover and develop the academic and intellectual skills of the students. To encourage attitudes of integrity, hard work, honesty, fairness and tolerance in students so that they give their best to the society, based on human values. To inculcate passion for based on excellence through Information and Communication Technology, Industrial exposures and Scientific projects leading to elevated career profile and National Development. To stimulate the students to perform at the peak of their potentials.

ACKNOWLEDGEMENT

I would also like to thank ^{Prof.} **Dr. Mahendra P. Dhore** Principal of **S.S.E.S Amt's science College, Nagpur**, for granting me this wonderful opportunity to be part of this project.

I would also like to thank ^{Prof.} **Dr. Kalpana Pawar** H.O.D Department of Mathematics, **S.S.E.S Amt's science College, Nagpur**, for their encouragement and insightful suggestions

I would also like to thank **Sandeep Sonaskar, and Other Teaching Staff of V S Informaties private limited, Nagpur** for constant encouragement and guiding me throughout the project work.

I would like to express my sincere obligation to my guide **Dr. Mrs Vidya Chavhan**, Co-Ordinator P.G. Department of mathematics, for suggesting the Topic and guiding me throughout the project work.

My earnest thanks to my friends, teaching and non-teaching staff of MSc. Department Of mathematics.

I am very much obliged to active suggestion and prepare inspiration to do this project work.

I am grateful to my friends who supported me during the monitoring work, analytical work and data compilation for the project.

It gives me immense pleasure to acknowledge all the staffs of the department for their constant guidance, kind-cooperation and valuable suggestions to complete and compile this work.

Prerana Gharde

CONTENT

Sr. No.	Particulars	Page No
1	Introduction of MATLAB	10-11
2	Solving some examples using MATLAB	12-16
3	A calculator to perform basic calculation arithmetic operations by using MATLAB GUI	16-24
4	Creating channels on THINGSPEAK	25-26
5	Creating alert on THINGSPEAK	27
6	Set up and Configure ESP32 Hardware	28-35
7	Application	36-37
8	Conclusion	38

INRODUCTION OF MATLAB

What Is MATLAB?

MATLAB is a high-performance language for technical computing. It integrates computation, visualization, and programming in an easy-to-use environment where problems and solutions are expressed in familiar mathematical notation.

Typical uses include:

- Math and computation
- Algorithm development
- Modelling, simulation, and prototyping
- Data analysis, exploration, and visualization
- Scientific and engineering graphics
- Application development, including Graphical User Interface building

MATLAB is an interactive system whose basic data element is an array that does not require dimensioning. This allows you to solve many technical computing problems, especially those with matrix and vector formulations, in a fraction of the time it would take to write a program in a scalar noninteractive language such as C or Fortran.

The name MATLAB stands for matrix laboratory. MATLAB was originally written to provide easy access to matrix software developed by the LINPACK and EISPACK projects, which together represent the state-of-the-art in software for matrix computation.

MATLAB has evolved over a period of years with input from many users. In university environments, it is the standard instructional tool for introductory and advanced courses in mathematics, engineering, and science. In industry, MATLAB is the tool of choice for high-productivity research, development, and analysis.

MATLAB features a family of application-specific solutions called toolboxes. Very important to most users of MATLAB, toolboxes allow you to *learn* and *apply* specialized technology. Toolboxes are comprehensive collections of MATLAB functions (M-files) that extend the MATLAB environment to solve particular classes of problems. Areas in which toolboxes are available include signal processing, control systems, neural networks, fuzzy logic, wavelets, simulation, and many others.

The MATLAB System

The MATLAB system consists of five main parts:

The MATLAB language.

This is a high-level matrix/array language with control flow statements, functions, data structures, input/output, and object-oriented programming features. It allows both "programming in the small" to rapidly create quick and dirty throw-away programs, and "programming in the large" to create complete large and complex application programs.

The MATLAB working environment.

This is the set of tools and facilities that you work with as the MATLAB user or programmer. It includes facilities for managing the variables in your workspace and importing and exporting data. It also includes tools for developing, managing, debugging, and profiling M-files, MATLAB's applications.

Handle Graphics.

This is the MATLAB graphics system. It includes high-level commands for two dimensional and three-dimensional data visualization, image processing, animation, and presentation graphics. It also includes low-level commands that allow you to fully customize the appearance of graphics as well as to build complete Graphical User Interfaces on your MATLAB applications.

The MATLAB Mathematical function library.

This is a vast collection of computational algorithms ranging from elementary functions like sum, sine, cosine, and complex arithmetic, to more sophisticated functions like matrix inverse, matrix eigenvalues, Bessel functions, and fast Fourier transforms.

The MATLAB Application Program Interface (API).

This is a library that allows you to write C and Fortran programs that interact with MATLAB. It include facilities for calling routines from MATLAB (dynamic linking), calling MATLAB as a computational engine, and for reading and writing MAT-files.

Examples based on MATLAB

Example No.1 Vectors

Let's start off by creating something simple, like a vector. Enter each element of the vector (separated by a space) between brackets, and set it equal to a variable. For example, to create the vector *a*, enter the following into the MATLAB command window and MATLAB should return the following:

```
a = [1 2 3 4 5 6 9 8 7]
```

```
a = 1 2 3 4 5 6 9 8 7
```

Let's say you want to create a vector with elements between 0 and 20 evenly spaced in increments of two (this method is frequently used to create a time vector):

```
t = 0:2:20
```

```
t = 0 2 4 6 8 10 12 14 16 18 20
```

Manipulating vectors is almost as easy as creating them. First, suppose you would like to add 2 to each of the elements in the vector *a*. The equation for that looks like:

```
b = a + 2
```

```
b = 3 4 5 6 7 8 11 10 9
```

Now suppose, you would like to add two vectors together. If the two vectors are the same length, it is easy. Simply add the two as shown below:

```
c = a + b c = 4 6 8 10 12 14 20 18 16
```

Subtraction of vectors of the same length works exactly the same way.

Example No.2 Plotting

It is also easy to create plots in MATLAB. Suppose you wanted to plot a sine wave as a function of time. First, make a time vector (the semicolon after each statement tells MATLAB we don't want to see all the values) and then compute the sin value at each time. The commands after the plot function (title, xlabel, ylabel) will add annotations to the plot.

```
t = 0:0.25:7;  
y = sin(t);
```

```
plot(t,y)  
title('Sine Wave as a Function  
of Time') xlabel('Time (secs)')  
ylabel('Amplitude')
```

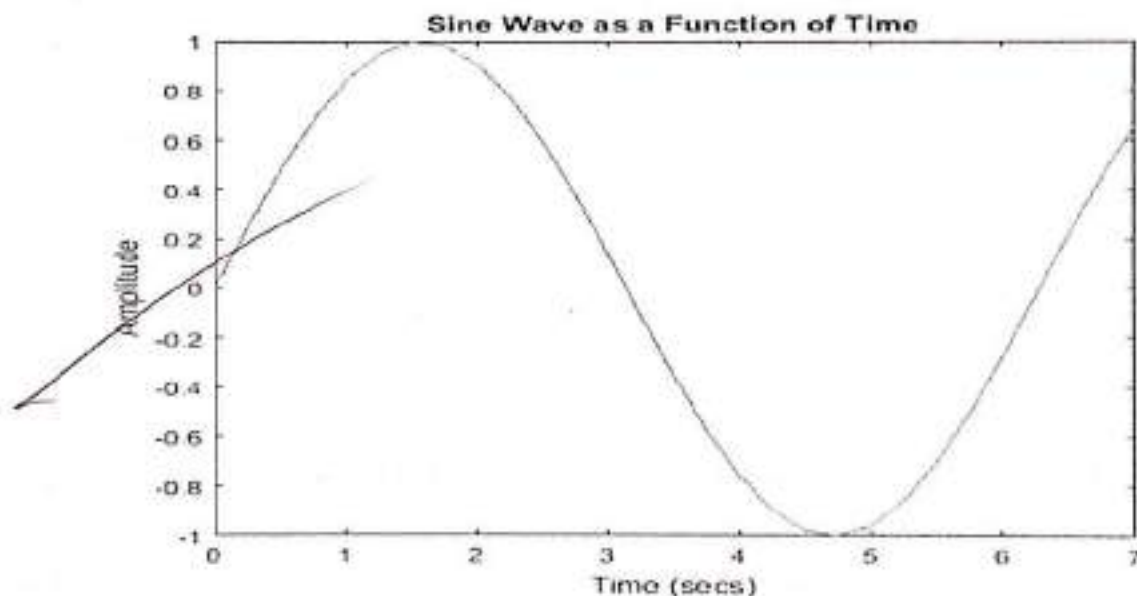

The plot contains approximately one period of a sine wave. Basic plotting is very easy in MATLAB, and the plot command has extensive add-on capabilities.

One of the most important functions in MATLAB is the plot function. The plot command also happens to be one of the easiest functions to learn how to use. The basic syntax of the function call is shown below. This code can be entered in the MATLAB command window or run from an m-file.

```
plot(x,y)
```

This command will plot the elements of vector y (on the vertical axis of a figure) versus the elements of the vector x (on the horizontal axis of the figure). The default is that each time the plot command is issued, the current figure will be erased; we will discuss how to override this below. Consider the following simple, linear function, $y=3x$

If we wished to plot this function, we could create an m-file with the following code to generate the basic plot shown below. $x = 0:0.1:100$; $y = 3*x$; $\text{plot}(x,y)$

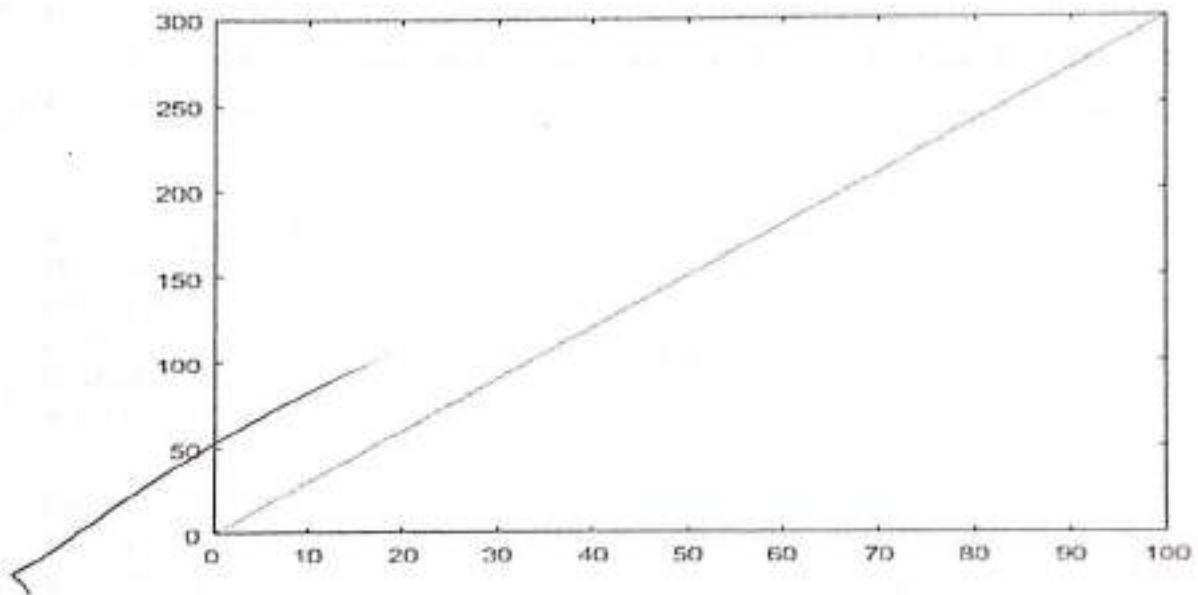

One thing to keep in mind when using the plot command is that the vectors x and y must be the same length. The other dimension can vary. MATLAB can plot a $1 \times n$ vector versus an $n \times 1$ vector, or a $1 \times n$ vector versus a $2 \times n$ matrix (you will generate two lines), as long as n is the same for both vectors.

The plot command can also be used with just one input vector. In that case the vector columns are plotted versus their indices (the vector $[1:1:n]$ will be used for the horizontal axis). If the input vector contains complex numbers, MATLAB plots the real part of each element (on the horizontal axis) versus the imaginary part (on the vertical axis).

Example No.3 Sub plotting

More than one plot can be put in the same figure on its own set of axes using the subplot command.

The subplot command allows you to separate the figure into as many plots as desired, and put them all in one figure. To use this command, the following line of code is entered into the MATLAB command window or run from an m-file.

```
subplot(m,n,p)
```

This command splits the figure into a matrix of m rows and n columns, thereby creating m*n plots on one figure. The p'th plot is selected as the currently active plot. For instance, suppose you want to see a sine wave, cosine wave, and tangent wave plotted on the same figure, but not on the same axes. The following code will accomplish this.

```
x =  
linspace(0,2*pi,  
50); y =  
sin(x); z =  
cos(x); w =  
tan(x);
```

```
subplot(2,2,1)  
plot(x,y)  
subplot(2,2,2)  
plot(x,z)  
subplot(2,2,3)  
plot(x,w)
```



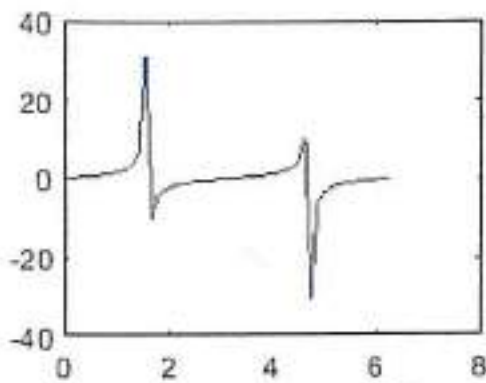
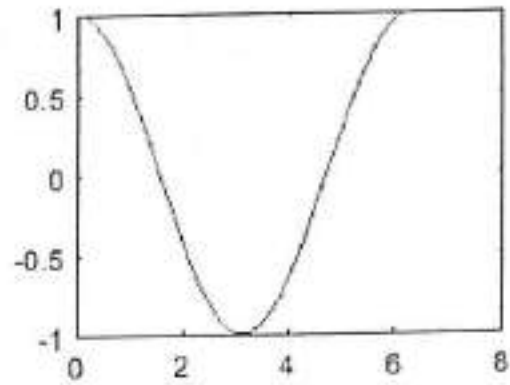
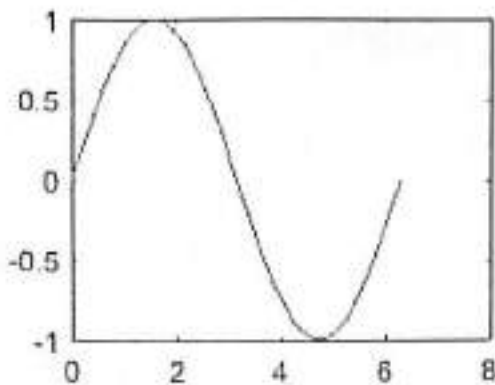

As you can see, there are only three plots, even though we created a 2 x 2 matrix of 4 subplots. We did this to show that you do not have to fill all of the subplots you have created, but MATLAB will leave a spot for every position in the matrix. We could have easily made another plot using the subplot (2,2,4) command. The subplots are arranged in the same manner as you would read a book. The first subplot is in the top left corner, the next is to its right. When all the columns in that row are filled, the left-most column on the next row down is filled (all of this is assuming that you fill your subplots in order (i.e. 1, 2, 3,...)).

One thing to note about the subplot command is that every plot command issued later will place the plot in whichever subplot position was last used, erasing the plot that was previously in it. For example, in the m-file above, if a plot command was issued later, it would be plotted in the third position in the subplot, erasing the tangent plot. To avoid this problem, the figure should be cleared (using `clf`), or a new figure should be specified (using `figure`).

A calculator to perform basic calculation arithmetic operations by using MATLAB GUI

A calculator to perform basic calculation arithmetic operations by using MATLAB GUI.
open the MATLAB software and in command write guide and press enter.

```
Command Window  
fx >> guide
```

now the app designer startup page will open and click on the blank app.

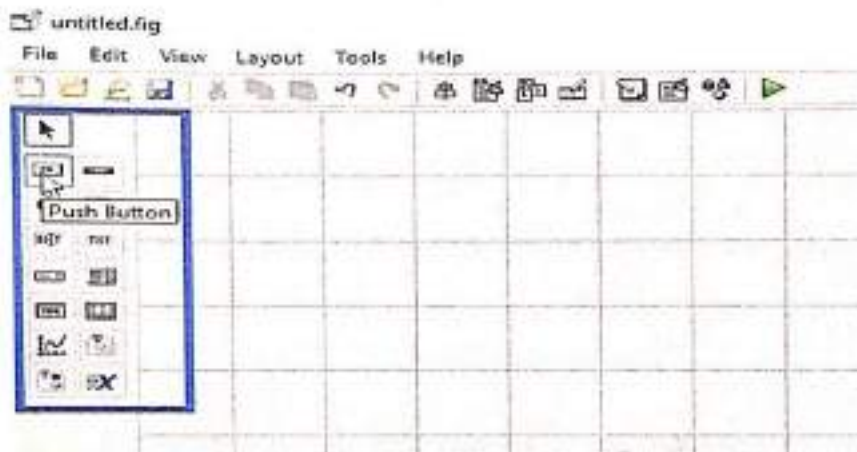

need a panel in which we will place the inputs

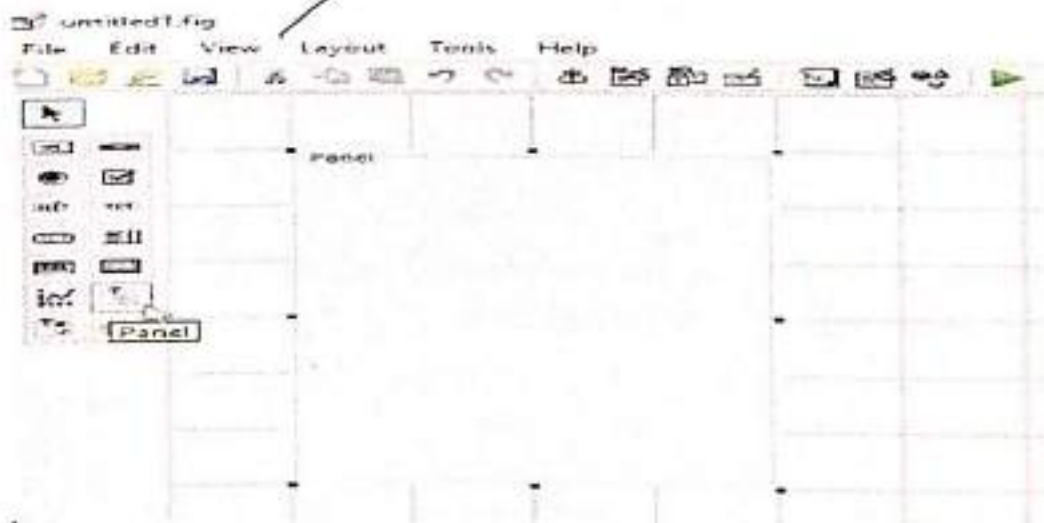

Now right click on the panel and click on the properties inspector.



You will see the properties of the panel. Now in the title I will give input if you don't want any then you can leave it by blank only then to increase the length font size. You can also change the background color or you can change the font color.

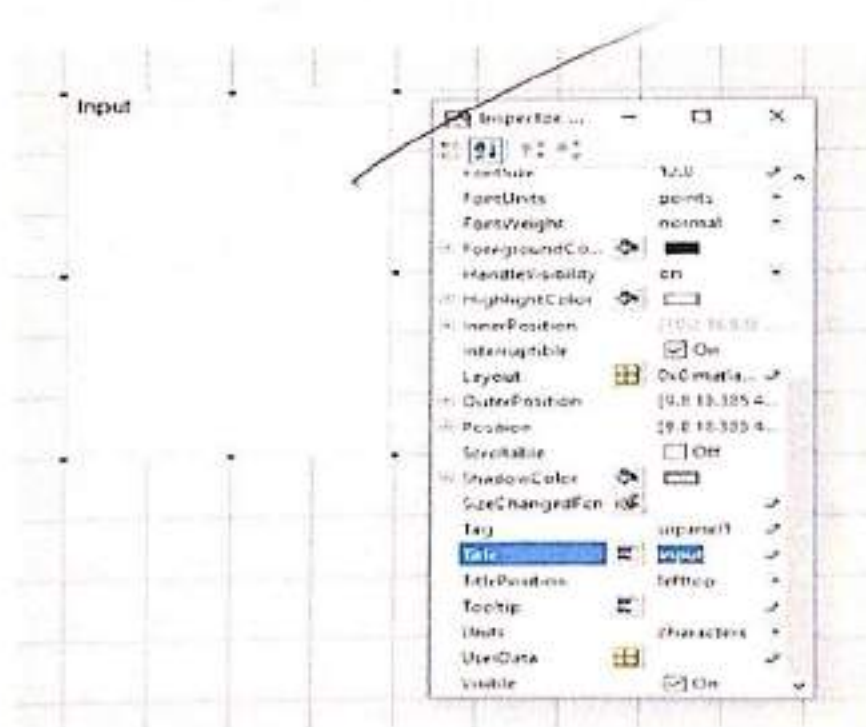

Now I will choose another panel in which four kinds of operation will be performed which are addition, subtraction, multiplication, and division. Change the name of the panel to operation.

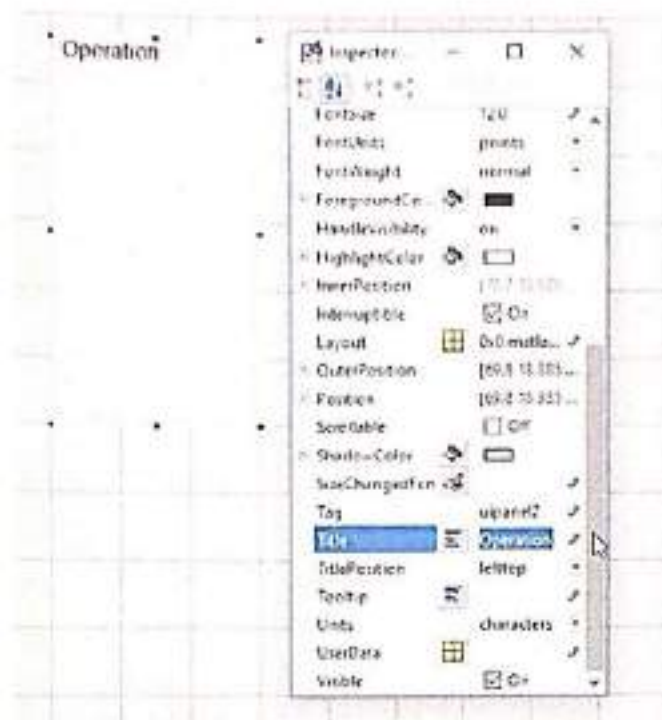

Then I will insert output panel and repeat the same process.

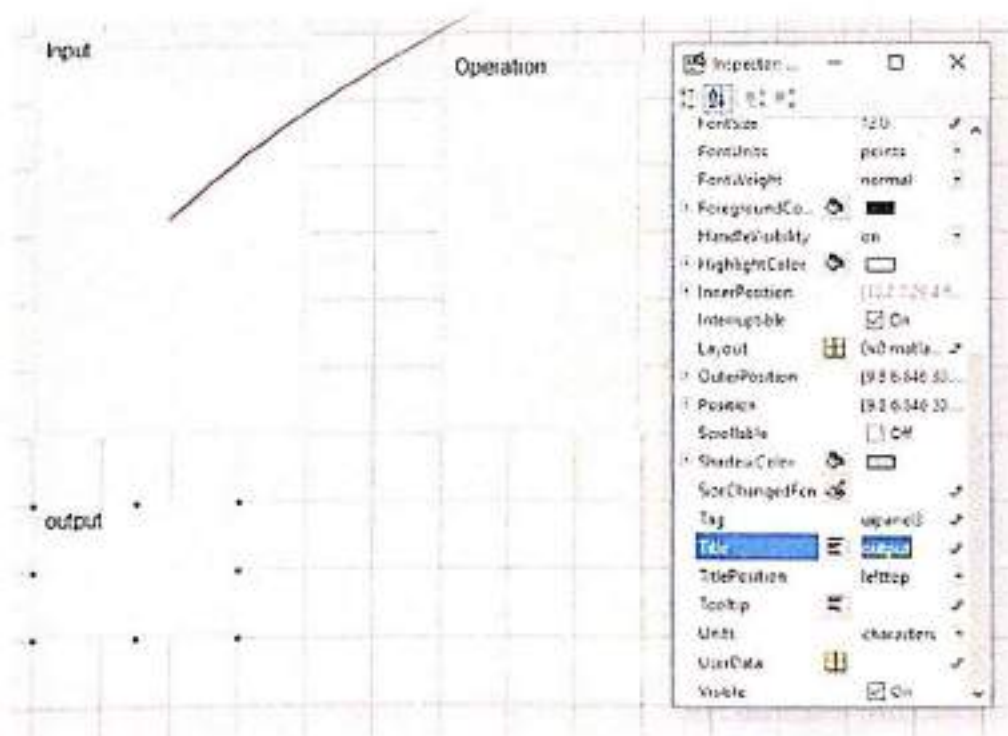

Now I need a toggle button just click it and place it in the operation section. Now give the title to the button in our case we will perform addition through this button so I give it "+" by renaming the string to + and now in the tag section write add.

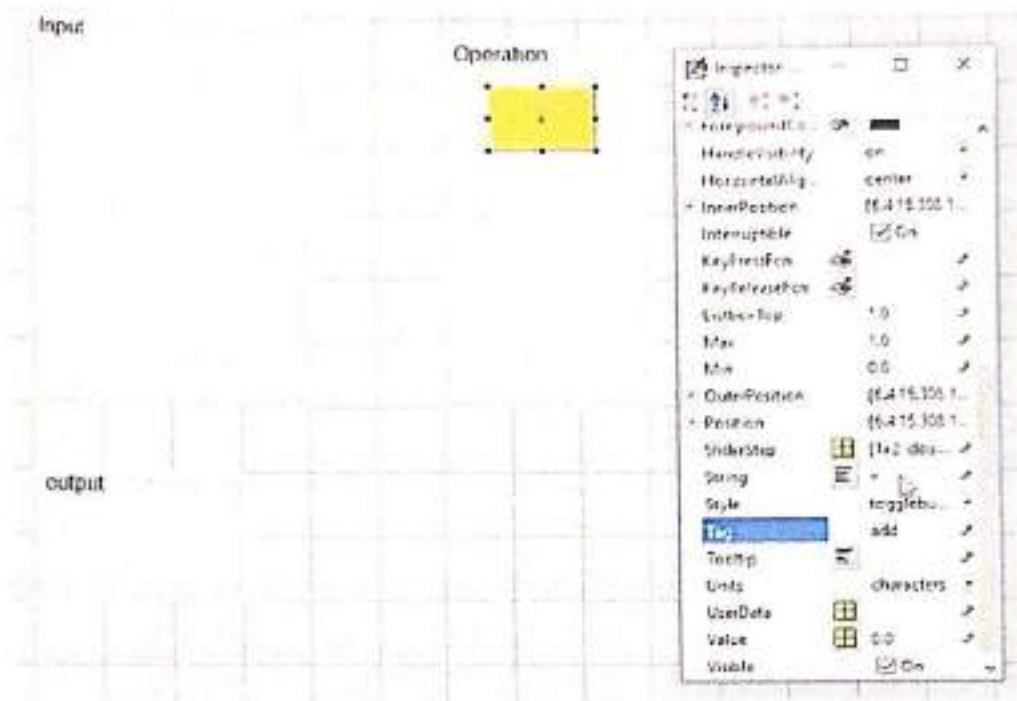

Now I will just copy this toggle button for another operation like subtraction, multiplication, and division. In the identifier section give the tag for each button like sub for subtraction, mul for multiplication, and div for the division.

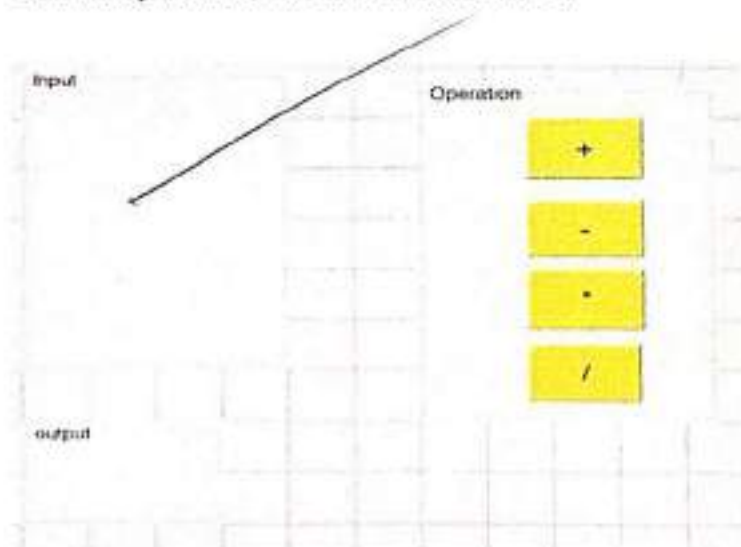

Now we will add the title name for which we will select the static text and give the title simple calculator.

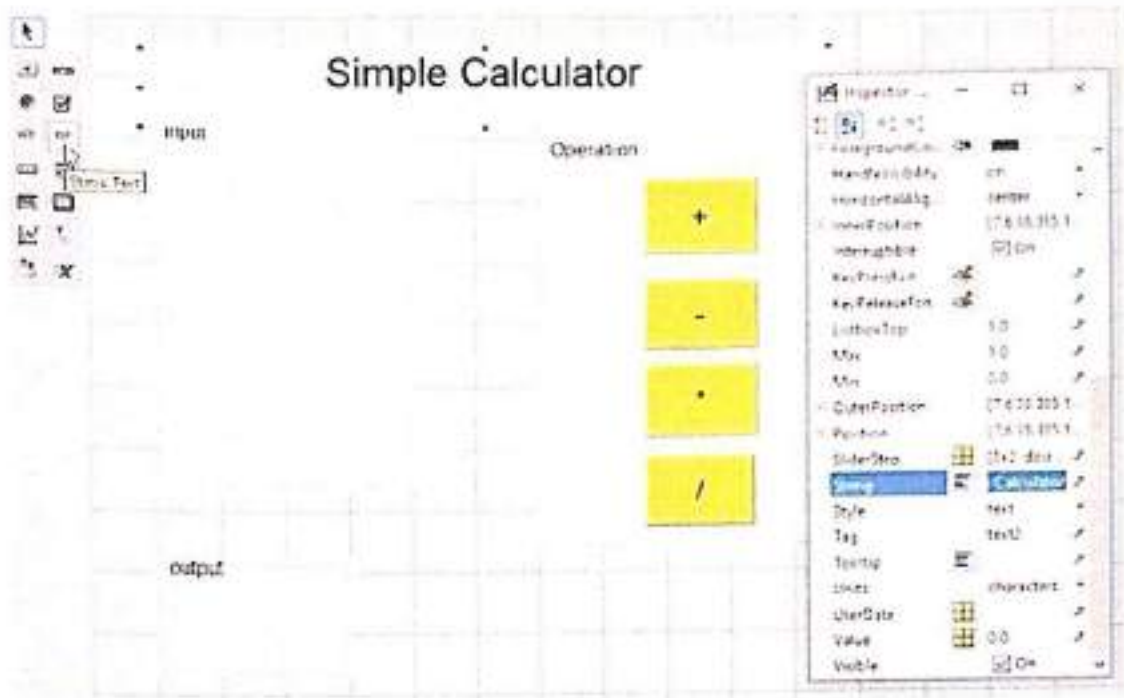

Now we need to edit text so to insert it we will select the edit field text and insert it in the input panel and in the tag write in1.

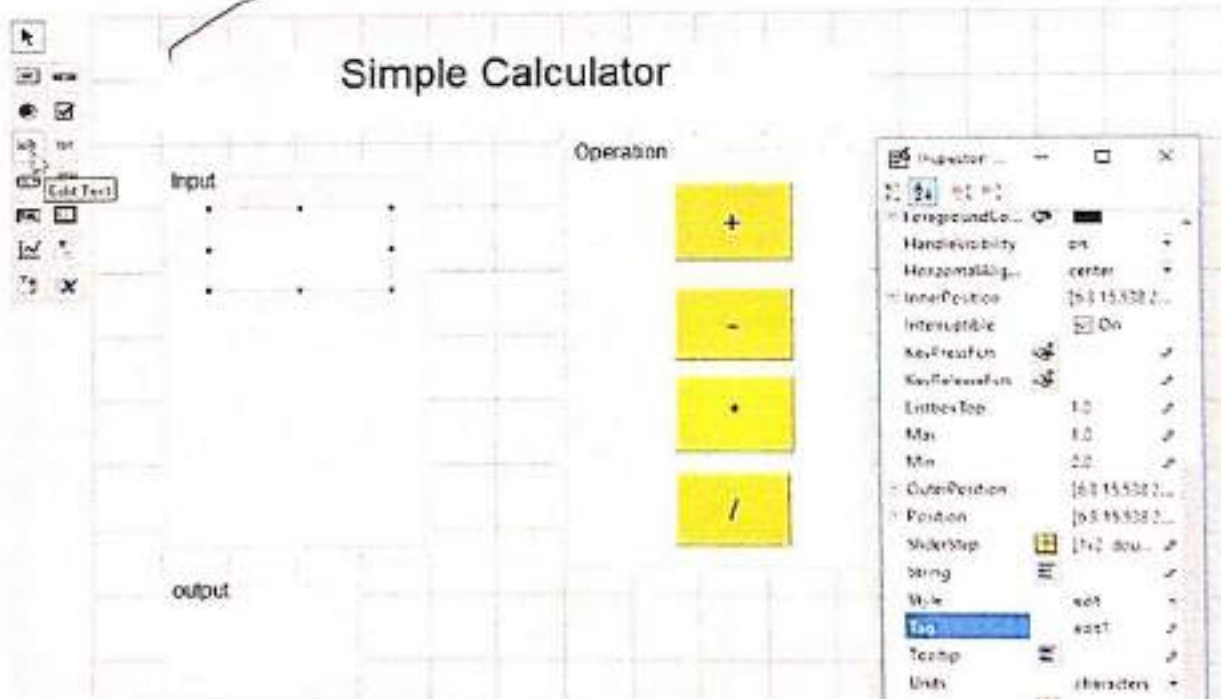

Similarly, we will add another text field for another input and in the tag give name in2. Now we will add one more panel for clear purpose then we will add toggle button and I will give it title as clear.

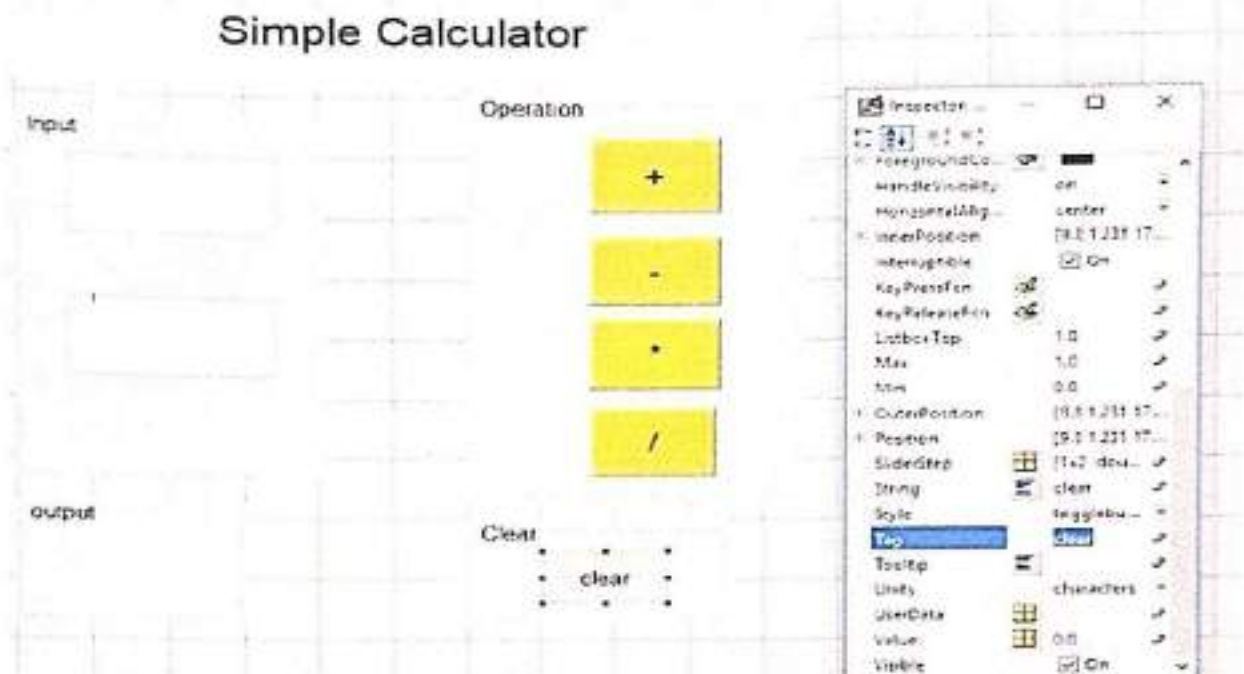

Now I want to add on output for which I will insert the text field and in the tag write the output.

The string should be blank space please keep in mind.

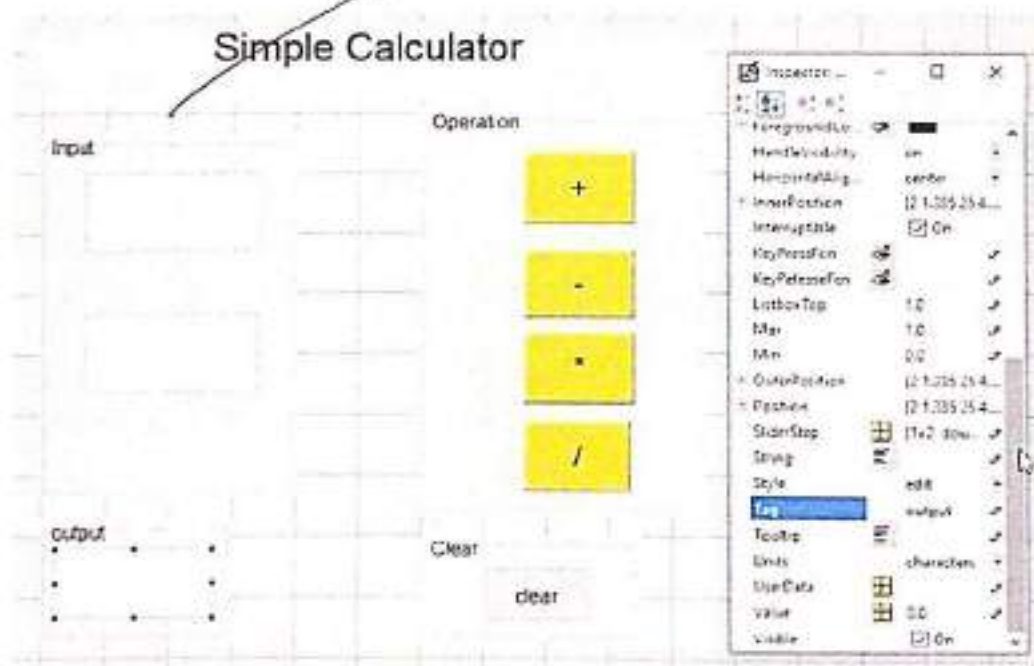

Now you can drag and drop anything and you can decrease the length also but once you run this you cannot change anything this window will disappear only. Now when we will click on the run button it will ask to save the file and click on yes and save the GUI.

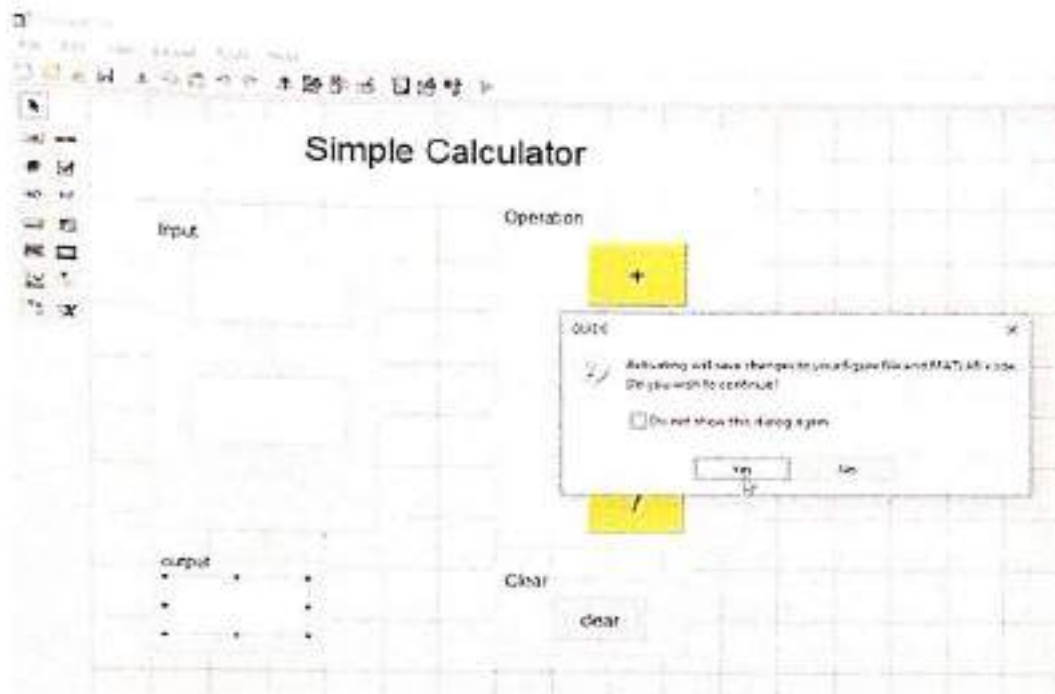

The calculator section will appear and it will generate the code automatically generated in editor window. You can enter the values in the field but you cannot get output because there is no program written, we will need to write Matlab script to perform different arithmetic operations.

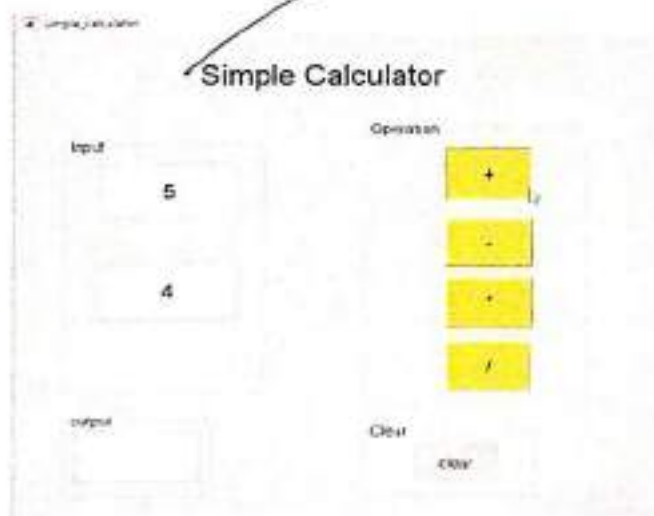

So you need to write code it will be automatically generated in the editor

```

1  function varargout = simple_calculator(varargin)
2  % SIMPLE_CALCULATOR MATLAB code for simple_calculator.fig
3  % SIMPLE_CALCULATOR, by itself, creates a new SIMPLE_CALCULATOR or raises the existing
4  % singleton*.
5  %
6  % H = SIMPLE_CALCULATOR returns the handle to a new SIMPLE_CALCULATOR or the handle to
7  % the existing singleton*.
8  %
9  % SIMPLE_CALCULATOR('CALLBACK',hObject,eventData,handles,...) calls the local
10 % function named CALLBACK in SIMPLE_CALCULATOR.M with the given input arguments.
11 %
12 % SIMPLE_CALCULATOR('property','value',...) creates a new SIMPLE_CALCULATOR or raises the
13 % existing singleton*. Starting from the left, property value pairs are
14 % applied to the GUI before simple_calculator_OpeningFcn gets called. An
15 % unrecognized property name or invalid value makes property application
16 % stop. All inputs are passed to simple_calculator_OpeningFcn via varargin.
17 %
18 % *See GUI Options on GUIDE's Tools menu. Choose "GUI allowed only one
19 % instance to the singleton".
20 %
21 % See also: GUIDE, GUIDATA, GUIHANDLES

```

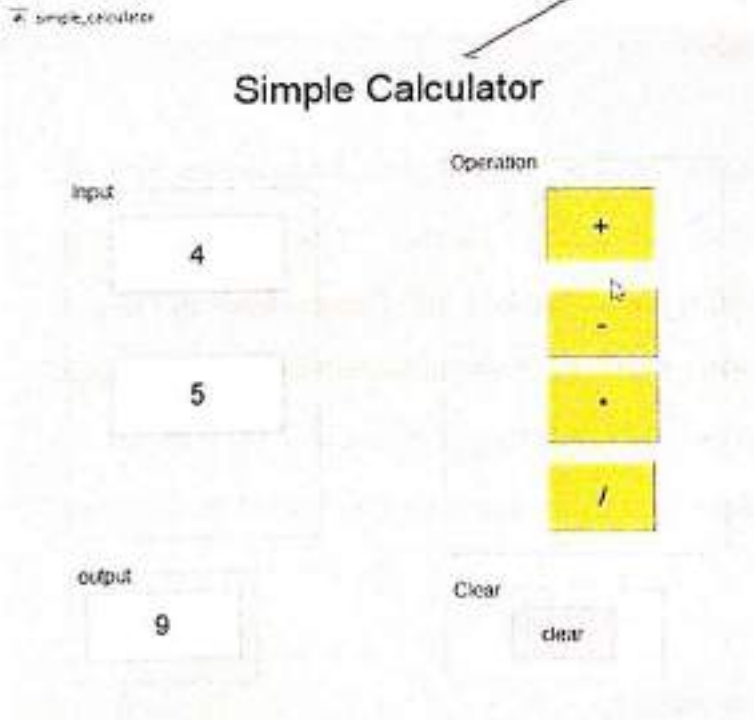

Creating channels on THINGSPEAK

Open any search engine on your computer and search Thingspeak.com , home page of the website get open now log in to the website and go to my channel now click on create new channel.

New channel get open, now name the channel and enter the field parameter i.e, temperature and humidity

Thingspeak™ Channels • Apps • Devices • Support • Commercial Use • How to Buy **PK**

New Channel

Name

Description

Field 1

Field 2

Field 3

Field 4

Field 5

Help

Channels store all the data that a Thingspeak application collects. Each channel includes eight fields that can hold any type of data, plus three fields for location data and cow-by status data. Once you collect data in a channel, you can use Thingspeak apps to analyze and visualize it.

Channel Settings

- **Percentage complete:** Calculator based on data entered into the various fields of a channel. Enter the name, description, location, URL, video, and tags to complete your channel.
- **Channel Name:** Enter a unique name for the Thingspeak channel.
- **Description:** Enter a description of the Thingspeak channel.
- **Fields:** Check the box to enable the field, and enter a field name. Each Thingspeak channel can have up to 8 fields.
- **Metadata:** Enter information about channel data, including JSON, XML, or CSV data.
- **Tags:** Enter keywords that identify the channel. Separate tags with commas.

Click on save channel, now go to API keys and copy the link given in the first box followed by the heading write the channel feed. Now open a new tab on your browser and paste the copied link on the search bar. Change the value of field 1 and write field 2 and also enter value of field 2 and click on enter key. Now go to the original page of website and open private view the value given by you above has been recorded on the graph below. Repeat the same procedure till 4 or 5 values recorded on the graph.

Entries: 23

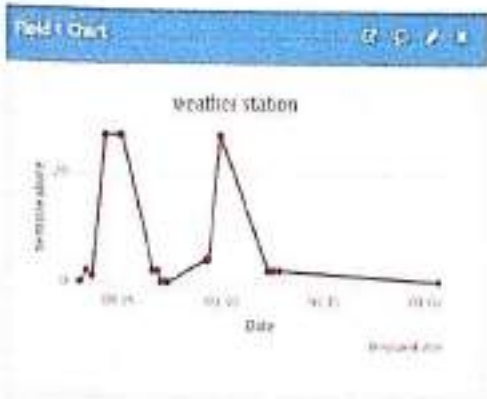

⚠️ We advise you to always use our platform responsibly, and to not use it for any illegal or harmful activities. If you have any questions, please contact our support team.



Creating alert on THINGSPEAK

Click on add widgets tab, select lamp indicator. A new page will open name the widgets as alert. Set the condition for the selected field. Choose the time interval and colour for the alert and click on create. Alert has been activated.

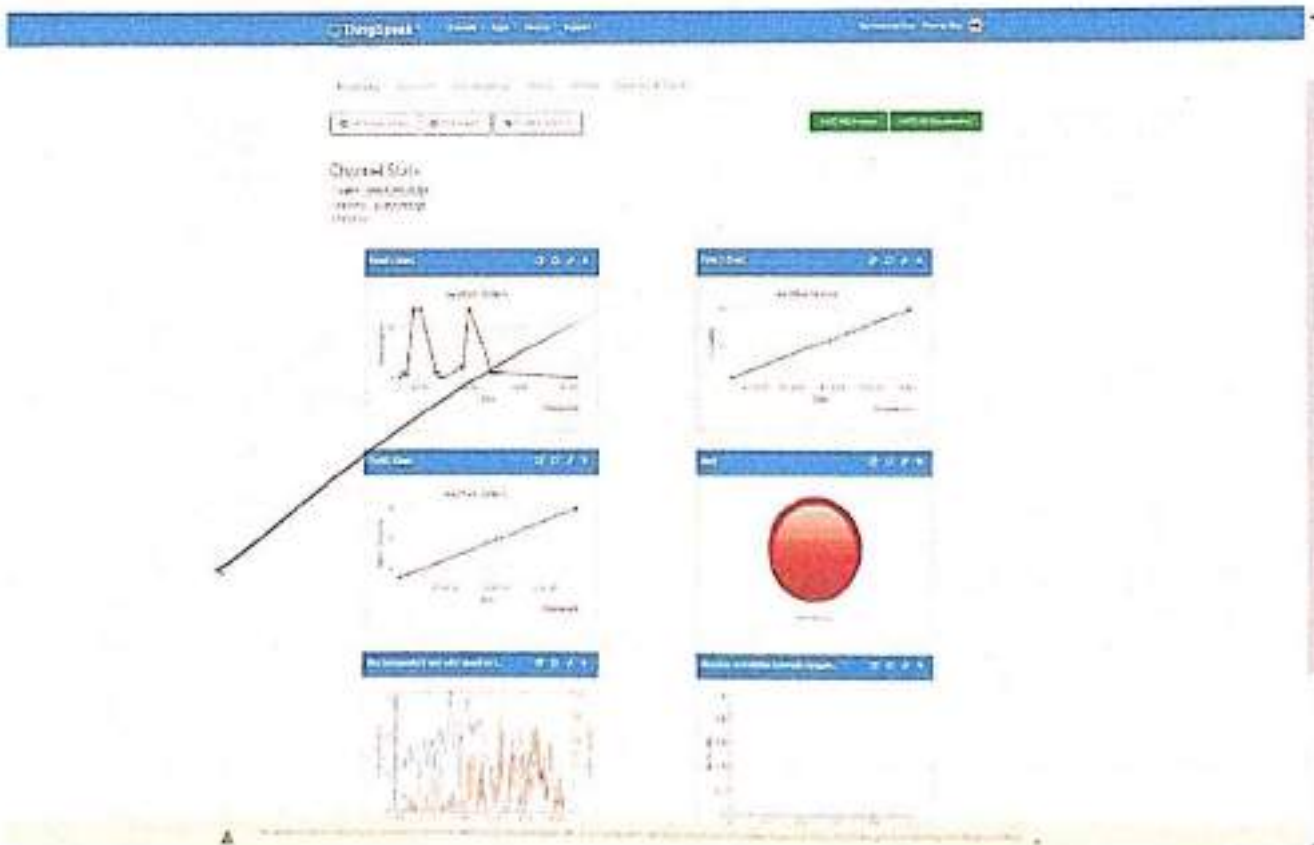
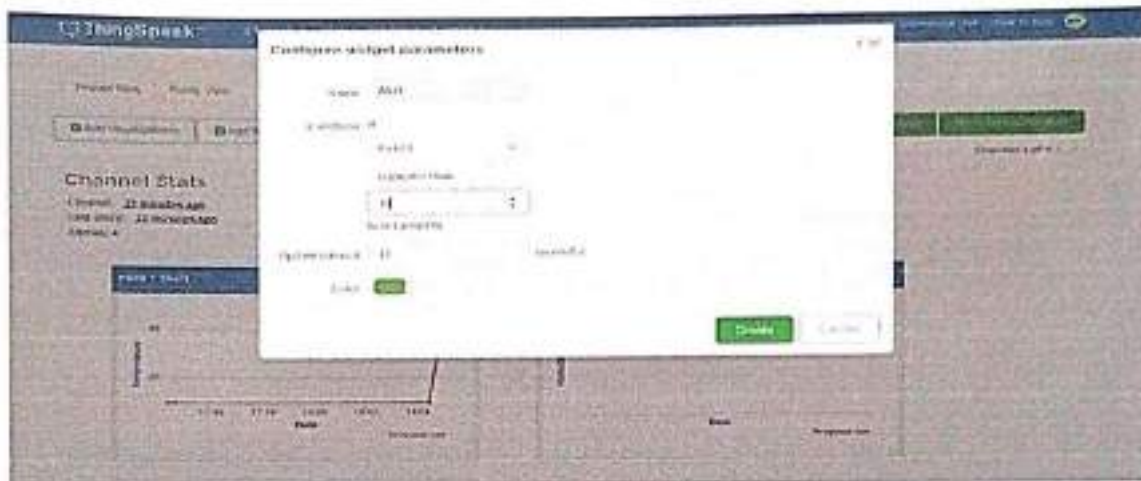

Set up and Configure ESP32 Hardware

Connection over USB

The ESP32 hardware communicates with the host computer via a USB cable as shown.

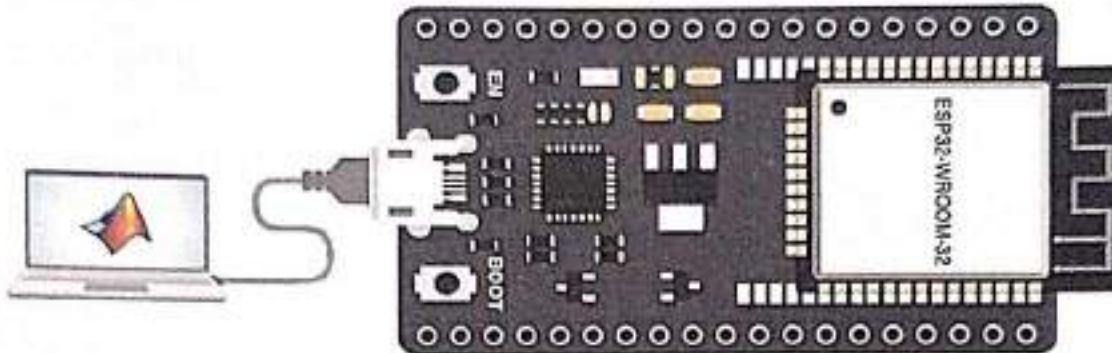

To configure your ESP32 hardware to communicate via USB:

1. Connect the ESP32 hardware via USB, by choosing the connection type USB. Click Next.

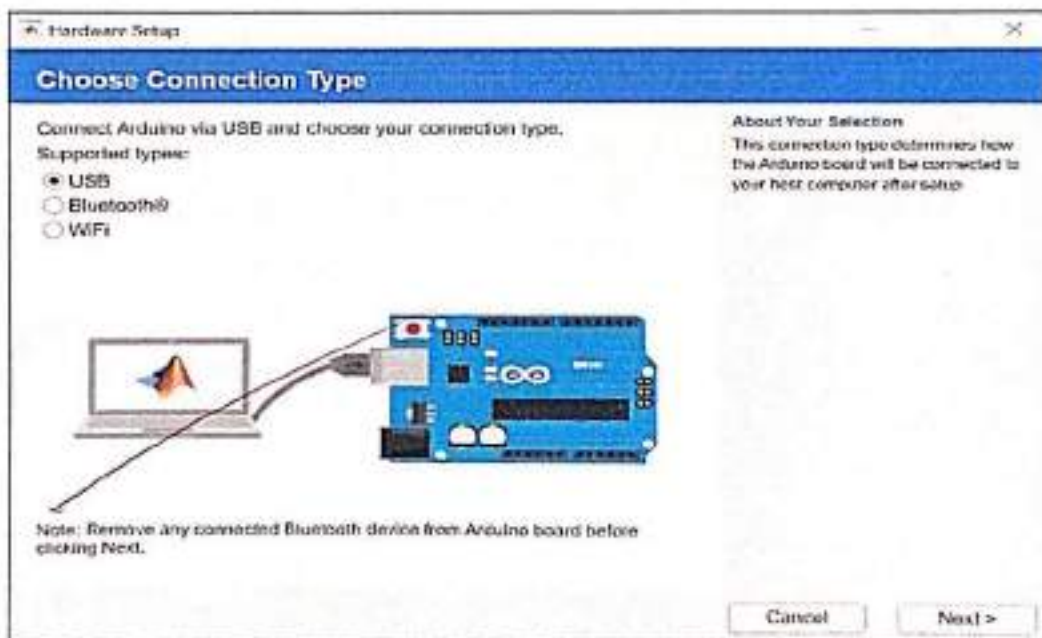

3. In the **Upload Arduino Server** screen, choose the board type and the port number from the **Choose board** and **Choose port** menus.

The supported ESP32 boards are ESP32-WROOM-DevKitC and ESP32-WROOM-DevKitV1.

Then, select the libraries that you want to include in your ESP32 server.

4. Click **Program** to begin uploading the server to your ESP32 board.

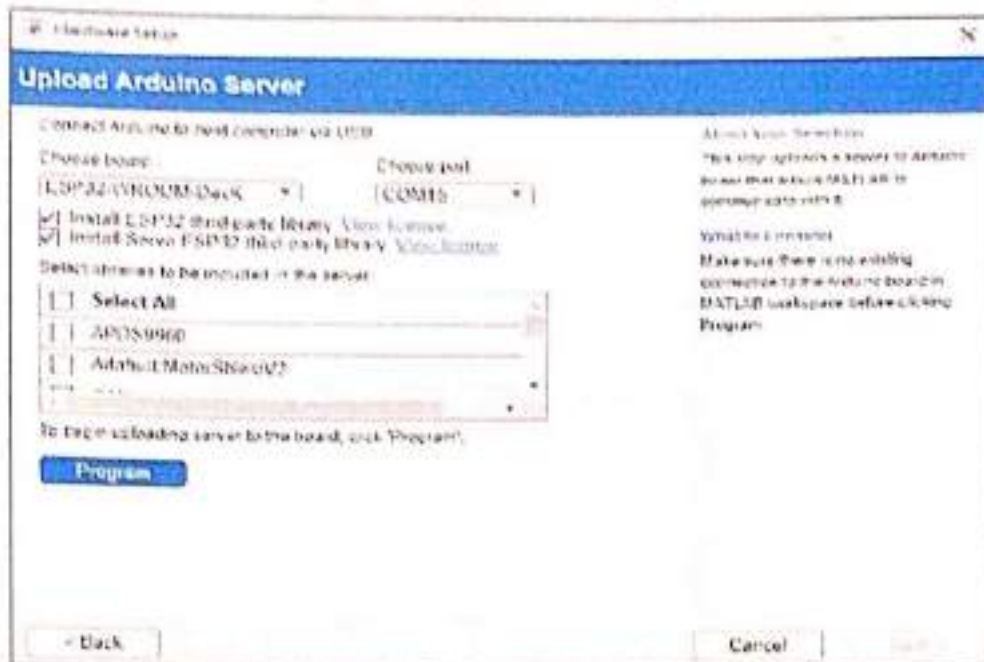

5. After the upload is successful, click **Next** to proceed.
6. Click **Test connection** to test the connection between your host computer and the ESP32 board.

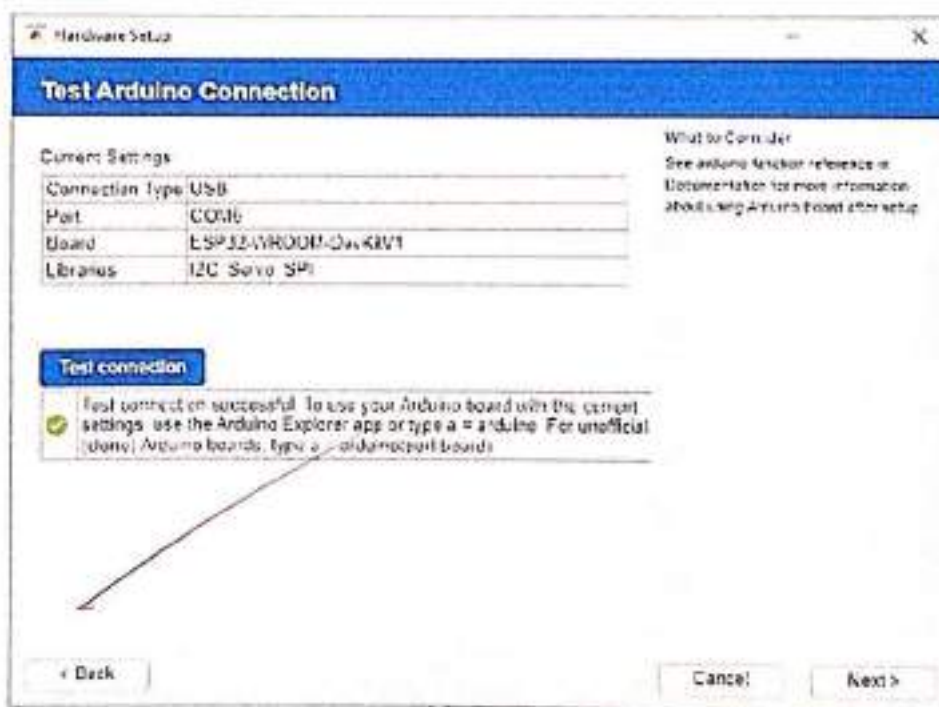

7. Click **Finish** to complete the hardware setup.

Matlab GUI Designing for Arduino:

Once your hardware is setup. Then Open the Matlab Software and to make the GUI application simply type `guide` in the command window and press enter this will open the `untitled.fig`. This is your form where you can add buttons, labels, check boxes etc.



GUI window will appear, now we will create two buttons which will be used to turn ON and turn OFF the LED. So we will click the push button and drag to the size.

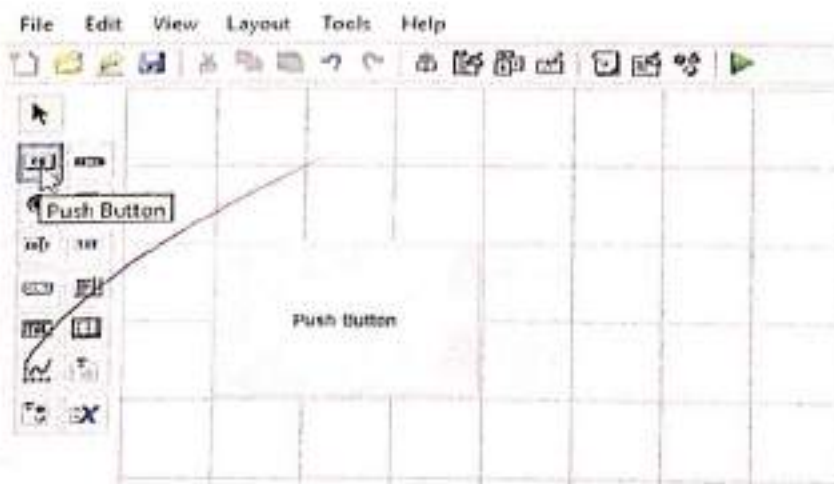

Now click on the button and a new window will open, which will show the properties of the button, in which we can change the color of the button and give a title to the button. As this button will be used to turn ON the LED, we will give it title ON and select the color green for this button and in the Tag section we will write on.

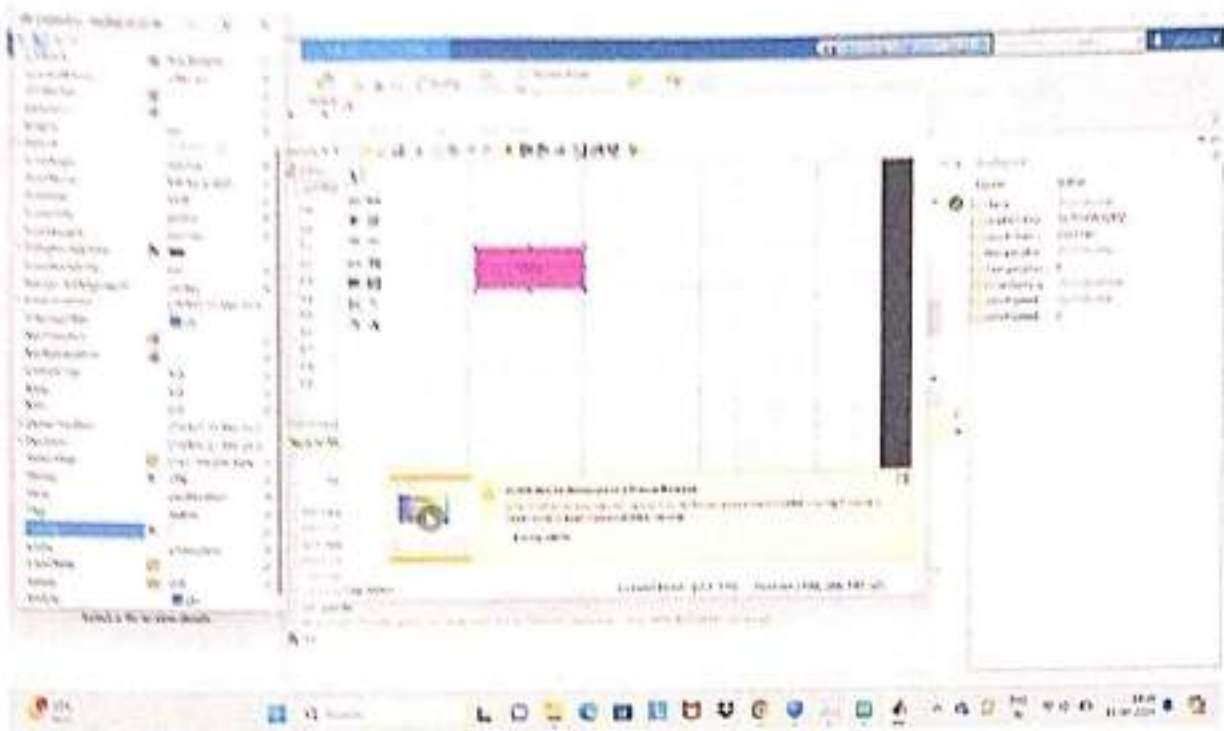

Similarly, we will insert another push button which we gonna be using for turning OFF the LED. We can insert another push button or just copy the ON button and paste it. Now we will change the color of the button to red and change the title to OFF and also change the Tag to off.

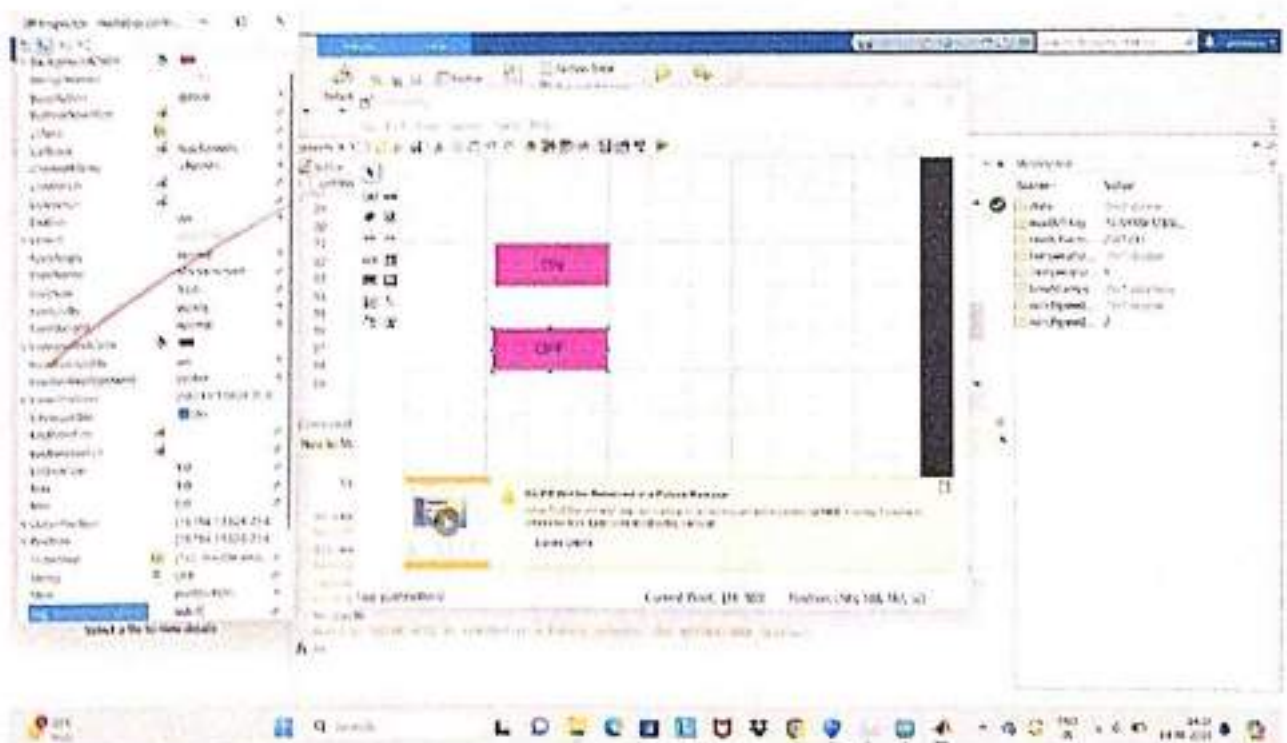

Now, to add a label simply click on the label “static text” and click on the GUI, then go ahead resize the label, write the text you want to display. In my case I will start with the “LED CONTROL” text. You can add multiple labels as per your requirement.

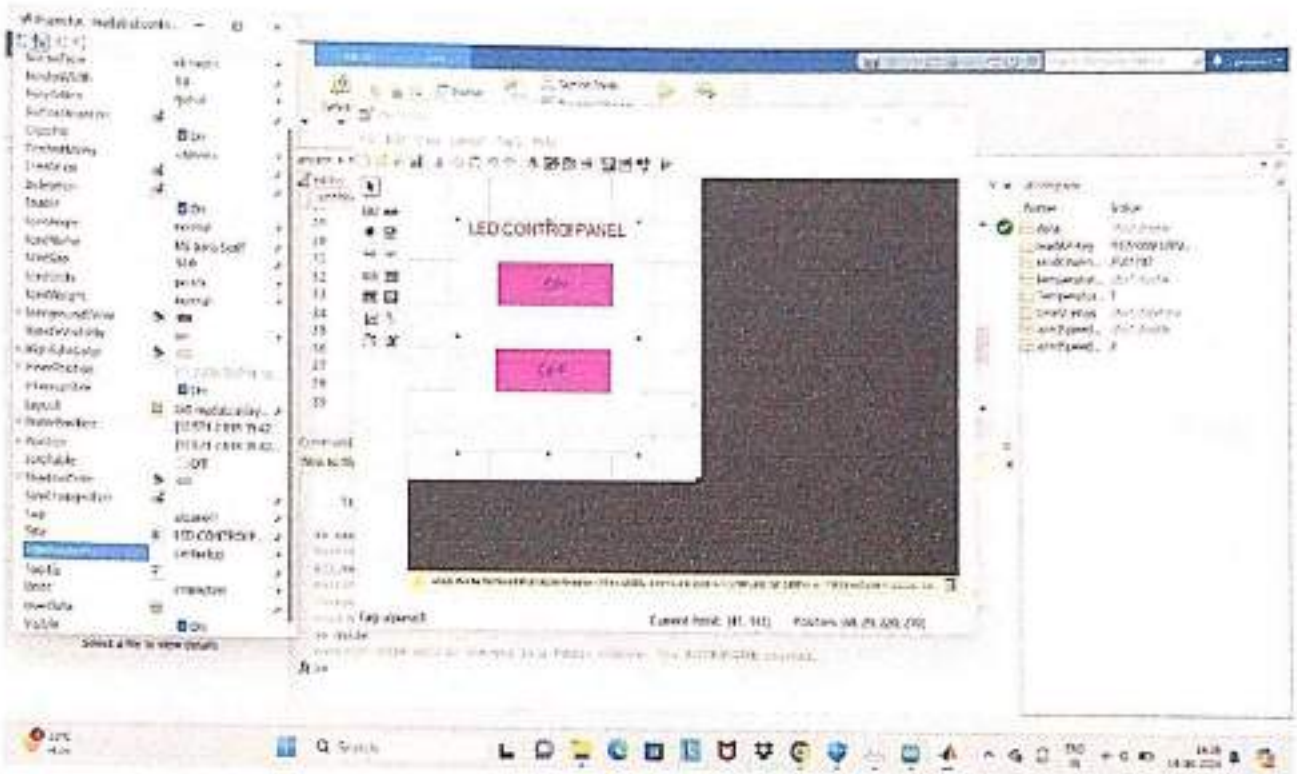

Now we will save the project, go to the file menu > click on the save and select the location where you want to save the file.

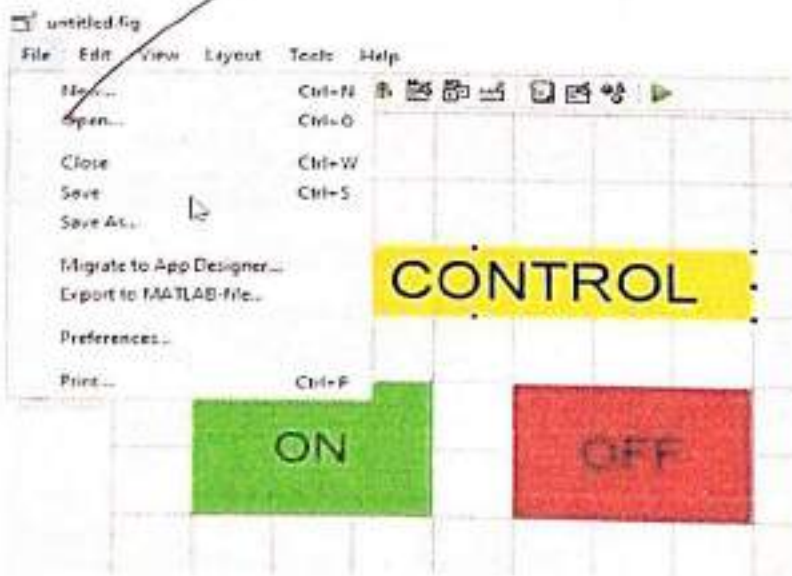

Code to switch the led on or off :

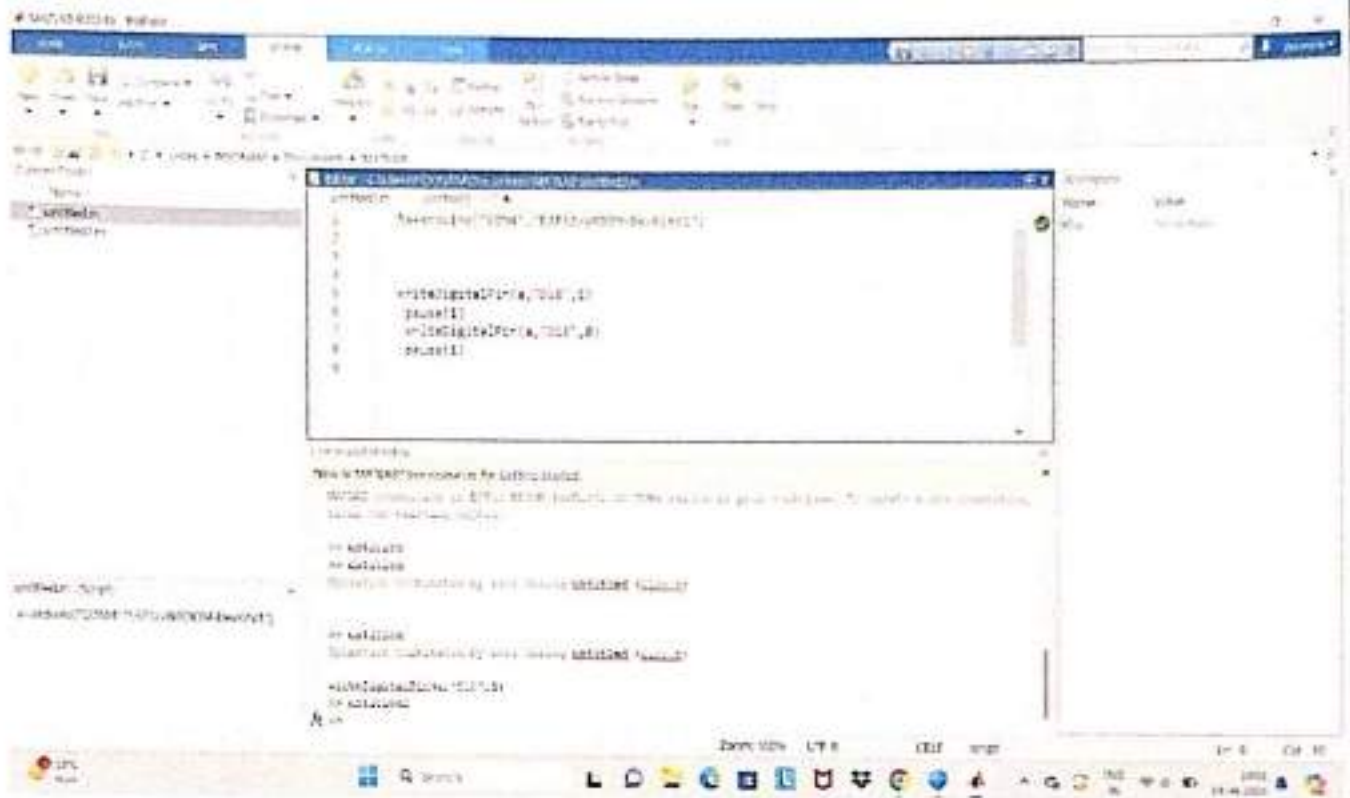

```
#include <Arduino.h>

void setup() {
  pinMode(LED_BUILTIN, OUTPUT);
}

void loop() {
  digitalWrite(LED_BUILTIN, HIGH);
  delay(1000);
  digitalWrite(LED_BUILTIN, LOW);
  delay(1000);
}
```

The screenshot shows a Windows IDE window titled "Arduino IDE" with the following code:

```
#include <Arduino.h>

void setup() {
  pinMode(LED_BUILTIN, OUTPUT);
}

void loop() {
  digitalWrite(LED_BUILTIN, HIGH);
  delay(1000);
  digitalWrite(LED_BUILTIN, LOW);
  delay(1000);
}
```

The IDE interface includes a menu bar (File, Edit, View, Tools, Help), a toolbar, and a status bar at the bottom showing "Arduino IDE" and "C++".

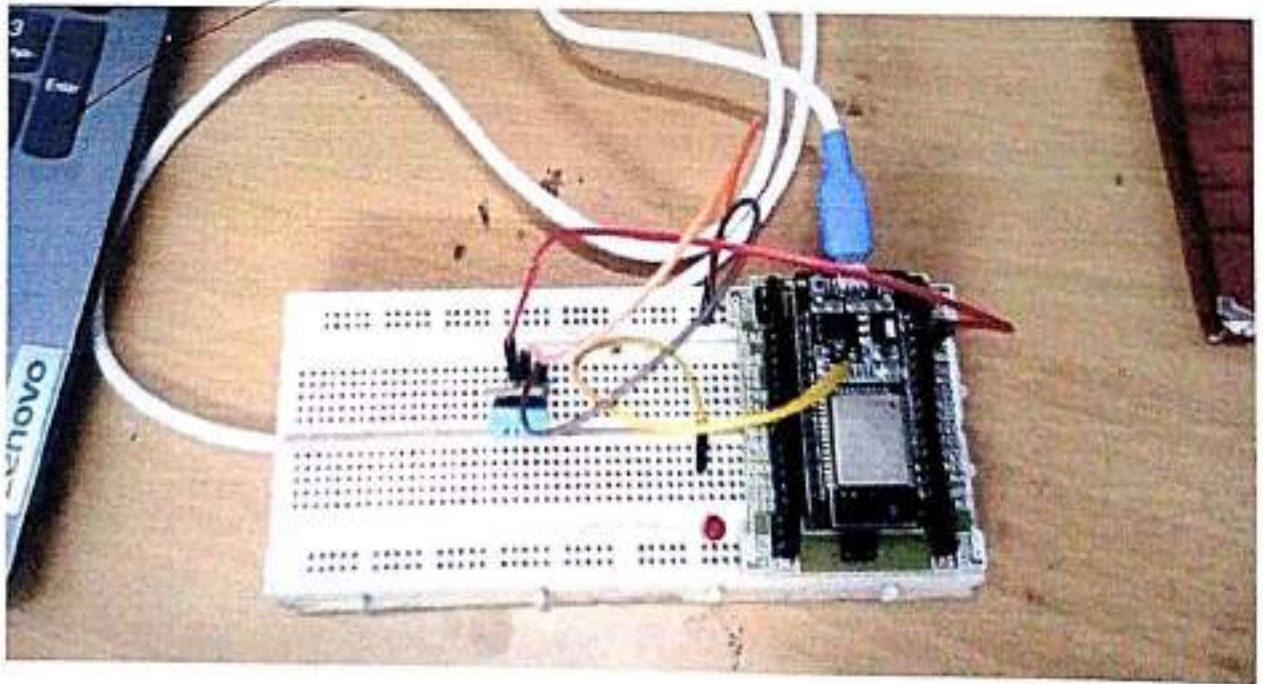

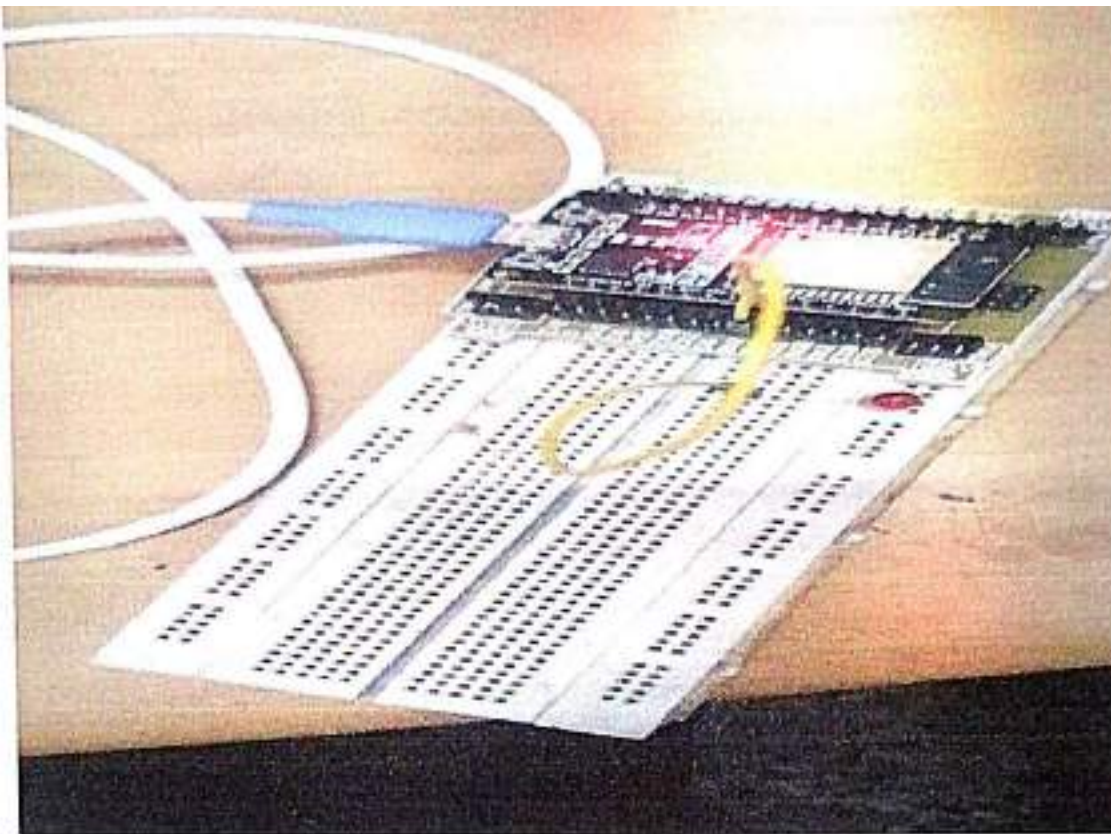

Real time data of the system has been recorded by the graph on thingspeak

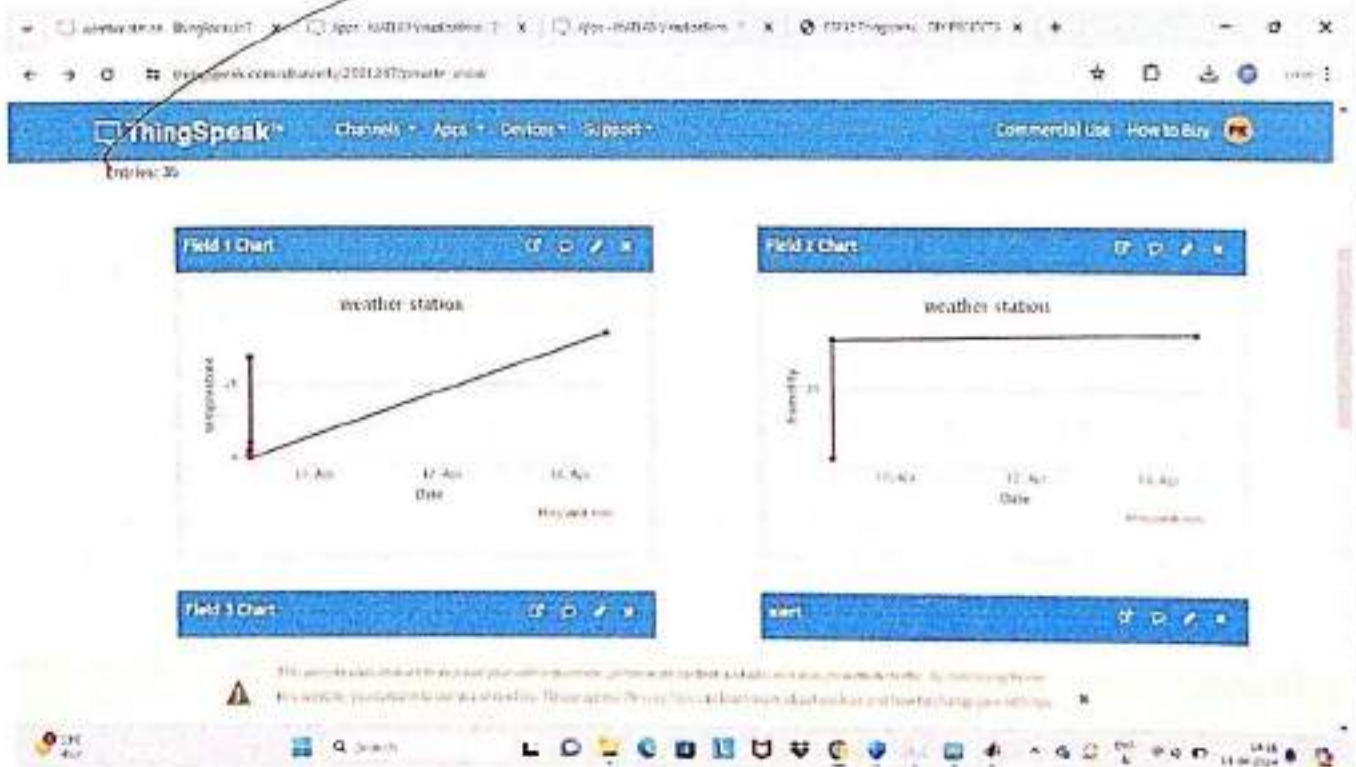

Applications of MATLAB

Being a powerful and high-performance programming language and environment, MATLAB is being used in a wide range of applications in various fields like engineering, science, technology, mathematics, and more. Some major applications of MATLAB are :

- **Statistics and machine learning (ML)**

This toolbox in MATLAB can be very handy for the programmers. Statistical methods such as descriptive or inferential can be easily implemented. So is the case with machine learning. Various models can be employed to solve modern-day problems. The algorithms used can also be used for big data applications.

- **Curve fitting**

The curve fitting toolbox helps to analyse the pattern of occurrence of data. After a particular trend which can be a curve or surface is obtained, its future trends can be predicted. Further plotting, calculating integrals, derivatives, interpolation, etc can be done.

- **Control systems**

Systems nature can be obtained. Factors such as closed-loop, open-loop, its controllability and observability, Bode plot, Nyquist plot, etc can be obtained. Various controlling techniques such as PD, PI and PID can be visualized. Analysis can be done in the time domain or frequency domain.

- **Signal Processing**

Signals and systems and digital signal processing are taught in various engineering streams. But MATLAB provides the opportunity for proper visualization of this. Various transforms such as Laplace, Z, etc can be done on any given signal. Theorems can be validated.

Analysis can be done in the time domain or frequency domain. There are multiple built-in functions that can be used.

- **Mapping**

Mapping has multiple applications in various domains. For example, in Big data, the MapReduce tool is quite important which has multiple applications in the real world. Theft analysis or financial fraud detection, regression models, contingency analysis, predicting techniques in social media, data monitoring, etc can be done by data mapping.

- **Deep learning**

Its a subclass of machine learning which can be used for speech recognition, financial fraud

detection, medical image analysis. Tools such as time-series, Artificial neural network(ANN), Fuzzy logic or combination of such tools can be employed.

- **Financial analysis**

An entrepreneur before starting any endeavour needs to do a proper survey and the financial analysis in order to plan the course of action. The tools needed for this are all available in MATLAB. Elements such as profitability, solvency, liquidity, and stability can be identified. Business valuation, capital budgeting, cost of capital, etc can be evaluated.

- **Image processing**

The most common application that we observe almost every day are bar code scanners, selfie (face beauty, blurring the background, face detection), image enhancement, etc. The digital image processing also plays quite an important role in transmitting data from far off satellites and receiving and decoding it in the same way. Algorithms to support all such applications are available.

- **Text analysis**

Based on the text, sentiment analysis can be done. Google gives millions of search results for any text entered within a few milliseconds. All this is possible because of text analysis. Handwriting comparison in forensics can be done. No limit to the application and just one software which can do this all.

- **Electric vehicles designing**

Used for modelling electric vehicles and analyse their performance with a change in system inputs. Speed torque comparison, designing and simulating of a vehicle, whatnot.

- **Aerospace**

This toolbox in MATLAB is used for analysing the navigation and to visualize flight simulator.

- **Audio toolbox**

Provides tools for audio processing, speech analysis, and acoustic measurement. It also provides algorithms for audio and speech feature extraction and audio signal transformation.





Conclusion

MATLAB is a complete solution that provides an interactive working environment and a powerful programming language. MATLAB is primarily designed to perform computational tasks such as mathematical operations, developing algorithms, data analysis and visualization, signal processing, etc. However, today MATLAB provides a rich library of functions and toolboxes that can perform a wide range of tasks from basic mathematical operations to scientific researches.

**SHRI SHIVAJI EDUCATION SOCIETY AMARAVATI'S
SCIENCE COLLEGE, CONGRESS NAGAR, NAGPUR.**

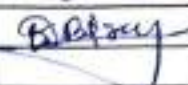
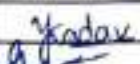
**Department of Mathematics
M.Sc. I Semester -II (2023-24)**

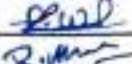
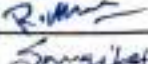
Practical On MATLAB (OJT Project on MATLAB) \ PYTHON PROGRAMMING

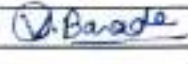
S.N.	Name of Student	Date	Topic	Signature
1	Dnyaneshwari K Bisen	15/05/2024	Project on MATLAB	
2	Harsh P. Kukde			
3	Himanshu P. Badwaik			
4	Ku. Khushi R. Yadav	15-05-24	Project on MATLAB	
5	Mangesh Shingane	15-05-24	Project on MATLAB	
6	Poonam S. Kulmethe	15-5-24	Project on MATLAB	
7	Prerana W. Gharde	14-5-24	Project on MATLAB	
8	Roshan N. khandare	16-05-24	Project on MATLAB	
9	Sangita R. Chaudhari	15-05-24	Project on MATLAB	
10	Shradha R. Bhonde			
11	Vaishanavi D. Barade	16-5-24	Project on MATLAB	



Signature of teacher





Head of the department

HEAD

**Department of Mathematics
Science College, Congress Nagar,
NAGPUR.**

PROJECT REPORT
ON
Heart Disease Prediction Using Machine
Learning

Submitted to
Rashtrasant Tukadoji Maharaj Nagpur University,
NAGPUR

In partial fulfillment of the requirement of

M. Sc. Semester - II (Computer Science) Examination

Submitted by
Yashashree S. Bobade
Chaitali A. Shripatre

Under the guidance of
Dr. Manish Wanjari
Assistant Professor
(Department of Computer Science)



DEPARTMENT OF COMPUTER SCIENCE
Shri Shivaji Education Society Amravati's
SCIENCE COLLEGE
Congress Nagar, Nagpur-12.

2023-2024

Shri Shivaji Education Society Amravati's
Department of Computer Science
Science College, Congress Nagar, Nagpur

CERTIFICATE

This is to certify that the project report entitled **Heart disease prediction using Machine Learning** is carried out and developed by **Yashashree S. Bobade** and **Chaitali A. Shripatre** in partial fulfillment of the **M.Sc. Semester - II (Computer Science)** and submitted to **Rashtrasant Tukdoji Maharaj Nagpur University, Nagpur** under my guidance and supervision.

To the best of my knowledge the matter presented in this project has not been presented earlier for similar degree/diploma.

Place: Nagpur
Date: 6/05/2024

06/05/2024
Project Guide
Dr. Manish Wanjari

Assistant Professor

Department of Computer Science
Science College, Congress Nagar, Nagpur

21/06/2024
(Dr. D.V. Bhavsagar)

EXTERNAL EXAMINER

INTERNAL EXAMINER

**SANTOSH SELOKAR INFORMATION
TECHNOLOGY (OPC) PVT. LTD.**



**Certificate No : SS 60684
Date : 4th May 2024**

APPRENTICESHIP CERTIFICATE

This is to certify that **Ms. Yashashree Bobade**, during her tenure with us she has successfully completed the **"Heart disease prediction project"** from 1st Februray 2024 to 30th April 2024.

We appreciate the your hand work and We wish you a very successfull Future.

Mr. Santosh Selokar
Director
SSIT Pvt. Ltd, Nagpur - 15



Regd. Off : Plot 11, Mitra Nagar, thakre Layout, Near Sahas Nasha Mukati kendra, Manewada Road, Nagpur - 440 027
Branch Off : Plot No 9, Fci Housing Society, 120 Railway Crossing Above Medplus Medical, Manish Nagar, Nagpur - 440
www.ssinfotect.org ✉ :ssitnagpur285@gmail.com ☎ +91 9146906649, +91 9657959184

**SANTOSH SELOKAR INFORMATION
TECHNOLOGY (OPC) PVT. LTD.**



**Certificate No : SS 60684
Date : 4th May 2024**

APPRENTICESHIP CERTIFICATE

This is to certify that **Ms. Chaitali Shripatre**, during her tenure with us she has successfully completed the **"Heart disease prediction project"** from 1st Februray 2024 to 30th April 2024.

We appreciate the your handrd work and We wish you a very successfull Future.



Mr. Santosh Selokar
Director
SSIT Pvt. Ltd, Nagpur - 15

Regd. Off : Plot 11, Mitra Nagar, thakre Layout, Near Sahas Nasha Mukati kendra, Manewada Road, Nagpur - 440 027
Branch Off : Plot No 9, Fcl Housing Society, 120 Railway Crossing Above Medplus Medical, Manish Nagar, Nagpur - 440 015
www.ssinfotect.org ✉ ssitnagpur285@gmail.com ☎ +91 9146906649, +91 9657959184

DECLARATION

To,

The Principal
Shri Shivaji Science College,
Congress Nagar, Nagpur-440012.

Respected Sir,

We the undersigned, hereby declare that the project work entitled **Heart disease prediction using Machine Learning** submitted to **Rashtrasant Tukadoji Maharaj Nagpur University, Nagpur** is our independent work . This is our original work and has not been submitted anywhere for any degree/diploma. The system presented herein has not been duplicated from any other source.

We understand that any such copying is liable to be punished in any way the University authority may deem fit.

Thanking You.

Place: Nagpur

Date: 6/05/2024

Yours Sincerely

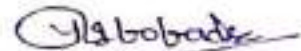

Yashashree S. Bobade



Chaitali A. Shripatre

ACKNOWLEDGEMENT

We wish to express our sincere thanks to many persons who helped us to develop our original project work.

At first, We express our sincere thanks Principal **Prof. M. P. Dhore**, Science College, Nagpur for providing the infrastructure and facilities without which it would have been impossible to complete this hard task.

In foremost this is to, **Prof. S. R. Pande** Head of Department of computer science who has aided as in completing this project report.

Our foremost thanks are to **Dr. Manish Wanjari**, who has guided us in completing this project report, We take the opportunity to express our deep sense of gratitude and whole hearted thanks for his inspiration and guidance throughout the course of this project.

We express our gratitude to all members of teaching and non-teaching staff of the Department of Computer Science for their co-operation during the course. Finally we thank our friends and specially who helped us in our endeavors.

Place: Nagpur

Yashashree S. Bobade

Date: 6/05/2024

Chaitali A. Shripatre

Table of Contents

Sr. No.	Topic	Page No.
1.	Introduction	1-2
2.	Objectives	2
3.	Literature Survey	2-4
4.	Methodology	4-6
5.	Plane of Research	6
6.	Results and Performance	6-11
8.	Conclusion and Future Scope	12-13
9.	References	13-14

1. Introduction

"Machine Learning is a way of Manipulating and extraction of implicit, previously unknown/known and potential useful information about data". Machine Learning is a very vast and diverse field and its scope and implementation is increasing day by day. Machine learning incorporates various classifiers of Supervised, Unsupervised and Ensemble Learning which are used to predict and find the Accuracy of the given dataset [1].

According to today's imbalanced lifestyle, the human heart is prone to critical sort of diseases. It's resulting in critical diseases and problems arising due to diabetes, stress, and intense smoking. All these factors seriously affect the human heart and lead to a variety of heart diseases. Heart disease is a term that assigns to a large number of medical conditions related to the heart. The term 'medical conditions' depicts the imbalanced health disorders, which means have a direct impact on the human heart and also in the rest of the body parts. Since heart disease portrays a prime issue of concern these days, the article targets to discover multiple techniques for the identification and prediction of heart disease [2].

Owing to many contributory risk factors, such as diabetes, high blood pressure, high cholesterol, irregular pulse rhythm, and several other factors, it is difficult to detect heart disease. To find out these seriousness of heart disease among humans, different machine learning techniques are introduced such as K-Nearest Neighbor Algorithm (KNN), Decision Trees (DT), Random Forest, Logistic Regression and Support Vector Machine (SVM). Evaluating the medical data is a complex process and in particular evaluating heart related data needs to be quantified with high precision and accuracy [3].

In this work, we analyze and estimate the use of different machine learning algorithm in the prediction of coronary heart disease by combining all the attributes in the dataset to develop the classification models. Random Forest, Logistic Regression, K-Nearest Neighbors, and Decision Tree classification models for coronary heart disease risk prediction are developed [1].

Correct analysis of all these symptoms will be beneficial at the point of making the necessary diagnosis. Practical, accurate, and early medical diagnosis of heart disease plays a significant role in taking preventive measures to prevent death. Over time, hospitals can collect

large volumes of research data and patient records. There are many open sources for accessing patient forms. In line with the developing technological opportunities, various researches can be carried out to diagnose the patients correctly and prevent this disease from becoming fatal using computer technologies. Today, it is well known that machine learning and deep learning algorithms play a significant role in the medical industry [3].

In this system, a heart disease data set is used. The main aim of this system is to predict the possibilities of occurring heart disease of the patients in terms of percentage. This is performed through data mining classification techniques. The classification technique is used for classifying the entire dataset into two categories namely yes and No. Classification technique is applied to the dataset through the machine learning classification algorithm namely Decision tree classification and Naïve Bayes Classification models. These models are used to enhance the accuracy level of the classification technique. This model performs both the classification and prediction methods. These models are performed using python Programming Language [4].

2. Objective

- To study the machine learning algorithm for prediction of heart disease
- To assist healthcare professionals in identifying high-risk individuals early on, enabling preventive measures to reduce the incidence and severity of heart disease.
- To classify individuals based on their likelihood of experience a cardiac event.
- To explore the effectiveness of different machine learning algorithms in predicting heart disease and compare their performance metrics.
- To develop a machine learning model to predict the possibilities of occurring heart disease of the patient using different models and real world dataset.

3. Literature Survey

Prediction of Coronary Heart Disease using Supervised Machine Learning Algorithms by Divya Krishnani (2019). In this paper proposed that likely reviews existing research on predicting coronary heart disease (CHD) using supervised machine learning algorithms.

Survey of Heart Disease Prediction and Identification using Machine Learning Approaches Ramya G. Franklin Research Scholar (2020) in this paper heart disease is highlighted as the major one among the various death factors. Predicting heart disease tends to be a bit complex due to insufficient knowledge and experience of the medical practitioners concerning warning signs of heart failure. There exist innumerable data volumes in the healthcare sector. By adopting the best appropriate machine learning techniques, early detection of heart-related diseases can be achieved and also preventing it from occurring.

Effective heart disease prediction using hybrid machine learning by A. Pandiaraj Department of ISE (2021). In this paper the literature survey encompasses a comprehensive review of existing methodologies, algorithms, and datasets utilized in heart disease prediction. By integrating multiple machine learning methods, the research aims to improve the accuracy and reliability of heart disease prediction models, thereby facilitating early detection and intervention strategies.

Prediction of Heart Disease Using Machine Learning- Aditi Gavhane (2018) in this paper we studied to develop an application which can predict the vulnerability of a heart disease given basic symptoms like age, sex, pulse rate etc. The machine learning algorithm neural networks has proven to be the most accurate and reliable algorithm and hence used in the proposed system.

Prediction of Heart Disease Prediction using Machine Learning Algorithms .Mr.Santhana Krishnan.J in this paper we studied that various algorithms, including decision trees and deep learning, are assessed for their effectiveness. Challenges such as data quality and model interpretability are highlighted as barriers to implementation in clinical settings. Future research directions emphasize addressing these challenges to improve predictive accuracy and applicability in cardiovascular healthcare. By integrating diverse data sources and enhance model transparency, machine learning holds promise for revolutionizing risk assessment, personalized treatment strategies in the prevention and management of heart disease.

M.Sc. Semester-II (Computer Science)

Heart disease prediction using machine learning algorithms- Harshit Jindal, Sarthak Agrawal, Rishabh Khera, Rachna Jain and Preeti Nagrath (2021) in this paper their study, published in the IOP Conference Series: Materials Science and Engineering, focused on analyzing various machine learning techniques for predicting heart disease. The authors likely reviewed existing research to explore the effectiveness of different algorithms in diagnosing heart conditions. Their work likely provides insights into the advancements and challenges in employing machine learning for cardiac health assessment, contributing to the growing body of knowledge in this critical medical field.

4. Methodology

4.1. Data Preparation

We take a data source which is comprised of medical history of 304 different patient of different age groups. This dataset gives us the much-needed information i.e. the medical attributes such as age, resting blood pressure, fasting sugar level etc. of the patient that helps us in detecting the patient that is diagnosed with any heart disease or not. This dataset contains 14 medical attributes of 303 patients that helps us detecting if the patient is at risk of getting a heart disease or not and it helps us classify patients that are at risk of having a heart disease and that who are not at risk. This Heart Disease dataset is taken from the UCI repository. According to this dataset, the pattern which leads to the detection of patient prone to getting a heart disease is extracted. These records are split into two parts: Training and Testing. This dataset contains 303 rows and 14 columns, where each row corresponds to a single record.

4.2. Tools and Libraries

We have use state of the python tools and libraries for the implementation of various machine learning based algorithms. The following libraries are used for implementation:

Numpy: Numpy is a incredible library to perform mathematical and statistical operations due to its fast and memory efficient as it is optimized to work with latest CPU architecture. Numpy provides an n-dimensional array type, the `nd_array`, which describes a collection of items of same type.

Pandas: The pandas library in python is a powerful tool for data manipulation and analysis. It provides data structures and functions to efficiently handle structured data, such as tabular data and time series. With pandas you can easily load, clean, transform, analyze, and visualize data.

Matplotlib: Matplotlib is python library used for creating static, animated, and interactive visualizations in python. Its widely used for plotting various types of graphs, charts, histogram and more.

Seaborn: Seaborn library is the widely popular data visualization library built on top of Matplotlib. It provides range of plotting functions that makes visualization and analysis of data easier.

4.3. Algorithms

Various machine learning algorithms are used to develop a model for predicting heart disease which can be helpful for practitioners or medical analysts for accurately diagnose heart disease that algorithms are given as below:

Random Forest Classifier

Random Forest is a versatile machine learning algorithm that creates a "forest" of decision trees, each trained on different subsets of the data and features, and combines their predictions to improve accuracy and reduce overfitting. It's widely used for classification and regression tasks due to its robustness and ability to handle large datasets with high-dimensional features. It constructs a multitude of decision trees during training, each tree based on a random subset of training data and features. Through a process called bagging, it combines to prediction of these trees to make the final prediction.

It basically uses an approach bagging, where various learning models are combined to improve the overall results. To performs the bagging operation, it produces manifold decision trees and synthesizes them together to obtain a refined result. It is one of the finest machine learning algorithms. It uses a random subset of features by splitting a node to obtain the best feature that contributes the most to build the model. The result even is increased further by adding random threshold values to each feature. Random Forest algorithm is also used to score the features. On the basis of how much impurity a feature adds to the model, it decides the relative feature importance. Also, RF is robust to outlier values.

Logistic Regression

Logistic Regression is a statistical method for binary classification, estimating the probability of an input belonging to one of two classes. It utilizes a logistic functions to transform predictions into probabilities. During training, it learn optimal feature weights by minimizing a loss function. The decision boundary separates classes in feature space. Predictions are made by applying learned weights to features, calculating class probabilities and assigning the input to the class with highest probability.

Logistic Regression is used for binary classification where we use sigmoid function that takes input as independent variables and produce probability value between 0 and 1. The logistic regression model transforms the linear regression function continuous value output into

5. Plan of Research

1. Literature Survey.
2. Study of related work on heart disease prediction using machine learning.
3. Evaluating the performance of different machine learning algorithms.
4. Develop a model to predict the possibilities of occurring heart disease of the patient using machine learning algorithm.
5. Conclude the result of machine learning algorithm for heart disease prediction.

6. Performance and Result

```

#importing Libraries
import numpy as np
import pandas as pd
import matplotlib.pyplot as plt
import seaborn as sns
import os
print(os.listdir())
dataset = pd.read_csv("heartDisease.csv")
dataset
type(dataset)
dataset.shape
dataset.head(5)
dataset.sample(5)
dataset.describe()
dataset.info()
info = ["age", "sex: 1: male, 0: female", "chest pain type. 1: typical angina, 2: atypical angina, 3: non
anginal pain, 4: asymptomatic", "resting blood pressure", "serum cholestoral in mg/dl", "fastin
blood sugar > 120 mg/dl", "resting electrocardiographic results (values 0,1,2)", "maximum hea
rate achieved", "exercise induced angina", "oldpeak = ST depression induced by exercise relati
to rest", "the slope of the peak exercise ST segment", "number of major vessels (0-3) colored
flourosopy", "thal: 3 = normal; 6 = fixed defect; 7 = reversable defect"]
for i in range(len(info)):
    print(dataset.columns[i]+" \n\n"+info[i])
dataset["target"].describe()
dataset["target"].unique()
#checking correlation between columns
print(dataset.corr()["target"].abs().sort_values(ascending=False))
#Data Analysis
y = dataset["target"]

```

M.Sc. Semester-II (Computer Science)

```

sns.countplot(y)
target_temp = dataset.target.value_counts()
print(target_temp)
print("Percentage of patients without heart problems: "+str(round(target_temp[0]*100/303.2)))
print("Percentage of patients with heart problems: "+str(round(target_temp[1]*100/303.2)))
dataset["sex"].unique()
sns.barplot(dataset["sex"])
dataset["cp"].unique()
sns.barplot(dataset["cp"])
dataset["fbs"].describe()
dataset["fbs"].unique()
sns.barplot(dataset["fbs"])
dataset["restecg"].unique()
sns.barplot(dataset["restecg"])
dataset["exang"].unique()
sns.barplot(dataset["exang"])
dataset["slope"].unique()
sns.barplot(dataset["slope"])
dataset["ca"].unique()
sns.countplot(dataset["ca"])
sns.barplot(dataset["ca"])
dataset["thal"].unique()
sns.barplot(dataset["thal"])
sns.distplot(dataset["thal"])
from sklearn.model_selection import train_test_split
predictors = dataset.drop("target",axis=1)
target = dataset["target"]
X_train,X_test,Y_train,Y_test = train_test_split(predictors,target,test_size=0.20,random_state=42)
X_train.shape

```

M.Sc. Semester-II (Computer Science)

```

X_test.shape
Y_train.shape
Y_test.shape
from sklearn.metrics import accuracy_score
from sklearn.linear_model import LogisticRegression
lr = LogisticRegression()
lr.fit(X_train,Y_train)
Y_pred_lr = lr.predict(X_test)
Y_pred_lr.shape
score_lr = round(accuracy_score(Y_pred_lr,Y_test)*100,2)
print("The accuracy score achieved using Logistic Regression is: "+str(score_lr)+" %")
print(Y_pred_lr.shape)
#Random Forest
from sklearn.ensemble import RandomForestClassifier
max_accuracy = 0
for x in range(2000):
    rf = RandomForestClassifier(random_state=x)
    rf.fit(X_train,Y_train)
    Y_pred_rf = rf.predict(X_test)
    current_accuracy = round(accuracy_score(Y_pred_rf,Y_test)*100,2)
    if(current_accuracy>max_accuracy):
        max_accuracy = current_accuracy
        best_x = x
#print(max_accuracy)
#print(best_x)
rf = RandomForestClassifier(random_state=best_x)
rf.fit(X_train,Y_train)
Y_pred_rf = rf.predict(X_test)
score_rf = round(accuracy_score(Y_pred_rf,Y_test)*100,2)
print("The accuracy score achieved using Decision Tree is: "+str(score_rf)+" %")

```

M.Sc. Semester-II (Computer Science)

Output:

```
print("Percentage of patients without heart problems: ",str(round(target_temp[0]*100/len(X)),2))
print("Percentage of patients with heart problems: ",str(round(target_temp[1]*100/len(X)))
```

```
Percentage of patients without heart problems: 45.54
Percentage of patients with heart problems: 54.46
```

```
score_lr = round(accuracy_score(Y_pred_lr,Y_test)*100,2)
```

```
print("The accuracy score achieved using Logistic Regression is: ",str(score_lr)+" %")
```

```
The accuracy score achieved using Logistic Regression is: 85.25 %
```

```
score_rf = round(accuracy_score(Y_pred_rf,Y_test)*100,2)
```

```
print("The accuracy score achieved using Random Forest is: ",str(score_rf)+" %")
```

```
The accuracy score achieved using Random Forest is: 98.16 %
```

7. Conclusion and Future Scope

7.1. Conclusion

A heart disease detection model has been developed using two ML classification modelling techniques. This project predicts people with heart disease by extracting the patient medical history that leads to a fatal heart disease from a dataset that includes patients' medical history such as chest pain, blood pressure, etc. This Heart Disease detection system assists a patient based on his/her clinical information of them been diagnosed with a previous heart disease. The algorithms used in building the given model are Logistic regression and Random Forest Classifier. Use of more training data ensures the higher chances of the model to accurately predict whether the given person has a heart disease or not. By using these, computer aided techniques we can predict the patient fast and better and the cost can be reduced very much. There are a number of medical databases that we can work on as these Machine learning techniques are better and they can predict better than a human being which helps the patient as well as the doctors. Therefore, in conclusion this project helps us predict the patients who are diagnosed with heart diseases by cleaning the dataset and applying logistic regression and random forest to get an accuracy of an average of 90.16% on our model random forest classifier which is better than the logistic regression models having an accuracy of 85.25%. Also, it is concluded that accuracy of random forest is highest between the two algorithms that we have used i.e. 90.16%.

7.2. Future Scope

The future scope for heart disease prediction using machine learning projects is promising. Here are some potential areas of advancement:

1. Integration of Advanced ML Techniques:

Incorporating machine learning models like logistic regression and random forest could enhance prediction accuracy by capturing intricate patterns in medical data.

2. Real-time Monitoring and Diagnosis:

Developing wearable devices integrated with ML algorithms to continuously monitor vital signs and predict heart disease risk in real time could revolutionize preventive healthcare.

3. Personalized Medicine:

Tailoring prediction models to individual patient characteristics, such as genetics, lifestyle, and medical history, could improve accuracy and enable personalized treatment plans.

4. Interdisciplinary Collaboration:

Collaborating with experts in cardiology, genetics, and data science could lead to more comprehensive models that consider a wide range of factors influencing heart disease risk.

5. Integration with Electronic Health Records(EHR):

Integrating ML-based prediction models with electronic health records systems could streamline diagnosis and treatment decisions by providing clinicians with actionable insights.

6. Global Health Impact:

Adapting ML models to diverse populations and healthcare systems worldwide could help address disparities in heart disease diagnosis and treatment outcomes on a global scale.

Reference

- [1] Harshit Jindal, Sarthak Agrawal, Kishabh Khara, Rachna Jain and Preeti Nagrath, "Heart disease prediction using machine learning algorithms" IOP Conference Series: Materials Science and Engineering, New Delhi (2021)
- [2] Ramya G., "Survey of Heart Disease Prediction and Identification using Machine Learning Approaches", 2020 3rd International Conference on Intelligent Sustainable Systems(ICISS)(2020)
- [3] A.Pandiaraj, "Effective heart disease prediction using hybrid machine learning", Third International Conference on Intelligent Communication and Technologies and Virtual Mobile Network(ICICV),IEEE .(2021)
- [4] Mr.Santhana Krishnan.J, "Prediction of Heart Disease Prediction using Machine Learning Algorithms", PG Student, Department of Computer Science, Anna University, BIT Campus, Tiruchirapalli-24
- [5] Prediction of Heart Disease Using Machine Learning- Aditi Gavhane, Isha Pandya , Gouthami Kokkula, Prof Kailas- Devadkar (PhD) Department of Information Technology Sardar Patel Institute of Technology Mumbai, India(2018).
- [6].Divya Krishnani, Anjali Kumari, Akash Dewangan, Aditya Singh, Nenavath Srinivas Naik , "Prediction of Coronary Heart Disease using Supervised Machine Learning Algorithms", 2019 IEEE Region 10 Conference (TENCON 2019)

SSESA's, Science College, Congress Nagar, Nagpur

Department of Computer Science

Apprenticeship Project List (OJT)

M.Sc. Semester-II (2023-24)

Sr. No.	Name of Students	Name of Topics	Co-Guide	Guide
1.	Akanksha Rajesh Singh Madhuri Chandrabhushan Singh	Movie Recommendation System in Machine Learning	----	Mr. A. A. Bodkhe
2.	Arushi Satish Adkane Sampada Rajendra Navghare	Breast Cancer Classification	Ms. S. S. Saygaonkar	Dr. S. R. Gedam
3.	Ashwini Sunil Mulak Janhvi Ramesh Kumbhalkar	Stock Price Prediction	----	Ms. A. M. Sheikh
4.	Chaitali Arvind Shripatre Yashashree Sudhakar Bobade	Heart Disease Prediction using Machine Learning	----	Dr. M. T. Wanjari
5.	Kalyani Rajesh Kolarkar Triveni Vasudev Manigam	Iris Flower Classification	Mrs. S. S. Khandalkar	Dr. A. A. Halder
6.	Madhavi Shankararo Choudhari	Customer Segmentation	----	Dr. J. K. Keche
7.	Ritika Mahesh Motwani Sejal Krishnakant Jakanwar	Email Spam Classifier	Mrs. A. A. Chandekar	Dr. J. K. Keche
8.	Shruti Suresh Dekate Vidhi Dhiraj Mishra	Speech Emotion Recognition by Machine Learning	----	Dr. M. T. Wanjari

Head

Department of Computer Science

Professor & Head

Department of Computer Science

S S E S Am's Science College,

Congress Nagar, Nagpur

PROJECT REPORT
ON
KYC AND ACCOUNT OPENING IN CREDIT CO-OPERATIVE

Submitted to
Rashtrasant Tukadoji Maharaj Nagpur University
NAGPUR

In partial fulfillment of
MASTER OF COMPUTER APPLICATION
MCA -II (SEMESTER-IV) Examination

Submitted by
Rajsi Datta Kingri

Under the guidance of
Dr. M. T. WANJARI
Assistant, Professor
Department Of Computer Science



DEPARTMENT OF COMPUTER SCIENCE
Shri Shivaji Education Society Amravati's,
SCIENCE COLLEGE
CONGRESS NAGAR, NAGPUR-12

2023-2024

Department of Computer Science,
Shri Shivaji Education Society Amravati's,
Science College, NAGPUR-440 012

CERTIFICATE

This is to certify that **Rajsi Datta Kingri** have successfully completed the project work entitled **KYC AND ACCOUNT OPENING IN CREDIT CO-OPERATIVE** under my guidance towards the fulfillment of the degree of **MASTER OF COMPUTER APPLICATION Final Year (SEMESTER-IV)** submitted to Rashtrasant Tukadoji Maharaj Nagpur University, Nagpur during academic year 2023-2024.

To the best of my knowledge the matter presented here in this project has not been presented earlier for similar degree.

Place: Nagpur
Date: 18/06/2024



18/06/24

Project Guide
Dr. M. T. WANJARI
Associate Professor
Department Of Computer Science
Assistant Professor
Department of Computer Science
S.S.E.S. Am's Science College,
Congress Nagar, Nagpur



EXTERNAL EXAMINER

INTERNAL EXAMINER



Trust Fintech Limited

(Formerly Trust Systems & Software (i) Ltd.)

CIN: U72103MH1998PLC117470

info@softtrust.com | www.softtrust.com

10th June, 2024

TO WHOMSOEVER IT MAY CONCERN

This is to certify that Miss. Rajs Datta Kingri from Shri Shivaji Science College, Nagpur, 4th Semester of MCA has successfully completed 6 Months of Internship in our company as PHP Developer (Programmer) segment. Her project name is "KYC & Account Opening in Credit Co-operative".

The project is under guidance of Mr. Mandar Deo (Technical Director).

Duration of internship from 27-Dec-2024 to 27-June-2024.

FOR TRUST FINTECH LIMITED

HR Manager

Regd. Office: 11/4, I.T. Park, Gayatri Nagar Parsodi, Nagpur Maharashtra, India, 440022 Ph- +91(712) 2221651

Pune Office: Office no 101, Building No A-2, Navkar Avenue, Bavdhan, Pune-411021 Ph- +91 9561112142

Mumbai Office: 509/510, E-Square, Shubash Road, Vile Parle(E), Mumbai-400057 Ph- +91(22) 26115252

DECLARATION

To,
The Principal,
Shri Shivaji Education Society Amravati's,
Science College, Congress Nagar,
Nagpur -440 012.

Respected Sir,

I undersigned, hereby declare that the project work entitled **KYC AND ACCOUNT OPENING IN CREDIT CO-OPERATIVE**, submitted to Rashtrasant Tukadoji Maharaj Nagpur University, Nagpur is my own independent work. This is my original work and has not been submitted anywhere for any degree. The system presented herein has not been duplicated from any other degree/course.

I understand that any such copying is liable to be punished in any way the university authority may deems fit.

Thanking you,

Place: Nagpur

Date:

Yours Sincerely,

RAJSI DATTA KINGRI

ACKNOWLEDGEMENT

I wish to express my sincere thanks to many persons who helped me to develop the project. We extend my thanks to respected Principal, **Prof. M. P. Dhore**, Science College, Nagpur for providing the infrastructure and facilities without which it would have been impossible to complete this hard task.

My foremost thanks are to **Prof. S. R. Pande**, Head of Department of Computer Science who has guided me in completing this project report. I take the opportunity to express my deep sense of gratitude and whole hearted thanks for his inspiration and guidance throughout the course of this project.

I am thankful to my Guide, **Dr. M. T. Wanjari**, Assistant Professor, Department of Computer Science for their constant inspiration and guidance throughout the course of this project work.

I express my gratitude to all members of teaching and non-teaching staff of the Department of Computer Science for their co-operation during the verification of the project.

Place: Nagpur

Date:

RAJSI DATTA KINGRI

M.C.A II Year (Semester-IV)

INDEX

Sr. No.	Name Of Topics	Page No.
1.	INTRODUCTION 1.1 Background 1.2 Objectives 1.3 Proposed System 1.3.1 Purpose 1.3.2 Scope	1-5
2.	SURVEY OF TECHNOLOGY	6-16
3.	REQUIREMENTS AND ANALYSIS 2.1 Problem Definition 2.2 Planning and Scheduling 2.3 Software and Hardware Requirements 2.4 Feasibility Study 2.4.1 Economic 2.4.2 Technical 2.4.3 Operational	17-21
4.	SYSTEM DESIGN 4.1 Program Flowchart 4.2 Basic Modules 4.3 Data Design 4.3.1 Database Design 4.3.2 Data Dictionary and Data Views 4.3.3 E-R diagram and DFDs 4.4 UML Diagram (Only for II and III Year Students) 4.4.1 Hierarchy Diagram 4.4.2 Use Case Diagram 4.4.3 Activity Diagram 4.4.4 Sequence Diagram	22-28
5.	IMPLEMENTATION AND TESTING 5.1 Screenshots 5.2 Testing Approach 5.2.1 Unit Testing 5.2.2 Integrated Testing 5.2.3 System Testing 5.3 Implementation and Maintenance	29-41
6.	CONCLUSIONS 6.1 Limitations of the System 6.2 Conclusion 6.3 Future Scope of the Project	42-44
7.	BIBLIOGRAPHY	

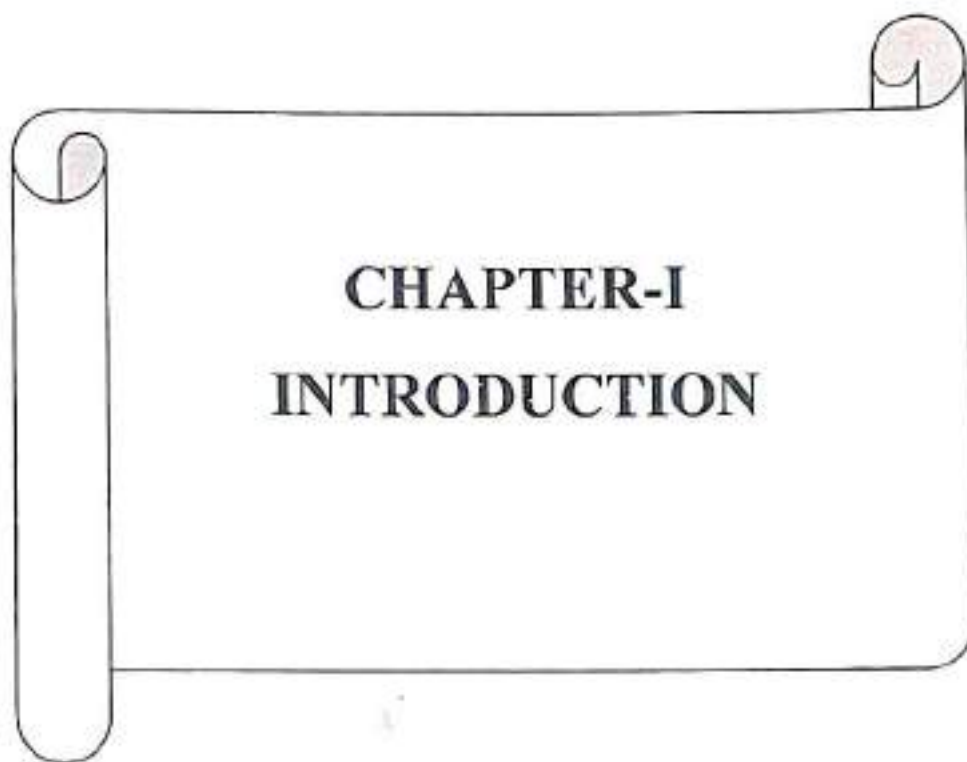

1.Introduction

KYC and Account Opening at Credit Co-Operative is a software in which the KYC stands for "Know Your Customer." It is a process used by businesses, particularly financial institutions, to verify the identity of their clients. The KYC process is essential for preventing fraud, money laundering, and other illegal activities. It typically involves collecting and verifying personal information such as identification documents, addresses, and sometimes even financial information.

This project is a comprehensive banking system tailored for a credit cooperative society, implemented in PHP. The system is designed to streamline and automate various banking operations, focusing on Know Your Customer (KYC) processes, account opening procedures, transaction management, and detailed reporting. By integrating these functionalities, the project aims to enhance efficiency, improve accuracy, and ensure compliance with regulatory standards.

The KYC form collects essential customer information to comply with regulatory requirements. The system verifies customer identity and assesses potential risks associated with the account.

The Account Opening Form facilitates the creation of new accounts by capturing necessary details such as personal information, account type, and initial deposit. Ensures that all required fields are filled out correctly to prevent errors and permissions.

The Transaction Form allows users to perform various banking transactions including deposits, withdrawals, and transfers. Tracks transaction history and ensures secure processing.

The Reports in the project can generate detailed reports displaying records of all opened accounts. Provides functionalities for viewing, sorting, and filtering data based on various criteria.

The Print Functionality can after generating reports, users can click a print button to view a print-friendly page. Ensures that all records are correctly formatted for physical documentation and printing. My Project KYC and account Opening at Credit Co-Operative is an software which is useful for the customers to ease their task and have benefits to the customers.

Enhanced Efficiency: Automated processes for KYC and account opening reduce wait times and manual errors, providing a smoother experience for customers. This ensures faster onboarding and more accurate data handling, enhancing overall service quality.

Improved Security: Robust KYC processes ensure that customer data is verified and protected, reducing the risk of fraud. By safeguarding sensitive information, the system creates a secure environment, enhancing customer trust and compliance with regulatory standards.

1.1 Background

The "KYC and Account Opening in Credit Cooperative" project was developed to address the specific needs of credit cooperative societies in managing customer data, streamlining account opening procedures, and ensuring regulatory compliance. Traditional banking methods often involve cumbersome paperwork, lengthy verification processes, and a high risk of manual errors. This project leverages modern web technologies, particularly PHP and MySQL, to create an efficient, secure, and user-friendly platform that enhances the overall banking experience for both customers and staff.

1.2 Objectives

Objectives of "KYC and Account Opening in Credit Cooperative"

- **Automate KYC Processes:** Streamline the collection and verification of customer data to ensure compliance with regulatory standards while reducing manual errors.
- **Simplify Account Opening:** Provide a user-friendly interface for opening new accounts, making the process quick and efficient for both customers and staff.
- **Enhance Transaction Management:** Enable secure and seamless financial transactions, giving customers better control over their accounts.
- **Improve Data Security:** Implement robust security measures to protect customer information and minimize the risk of fraud.
- **Generate Detailed Reports:** Offer comprehensive reporting tools to help users track account activities and make informed financial decisions.
- **Increase Operational Efficiency:** Automate and integrate key banking operations to reduce workload and improve overall efficiency within the credit cooperative.

- **Facilitate Regulatory Compliance:** Ensure adherence to legal and regulatory requirements governing KYC procedures and customer data management.

By using this microservices architecture, the KYC & Account Opening At Credit in Co-Operative Software in the backend can provide a robust, efficient, and scalable platform for managing the Transaction, Account Opening, KYC operations, Formation of Reports improving the satisfaction, and driving business growth.

1.3 Proposed System

1.3.1 Purpose

1.Efficiency: Banking software automates routine tasks, reducing manual effort and processing time.

2.Accuracy: It minimizes errors in data entry and calculations, ensuring precise financial transactions and record-keeping.

3.Security: Banking software incorporates robust security measures to protect sensitive customer data and prevent unauthorized access or fraud.

4.Customer Service: It provides a user-friendly interface for customers to access accounts, make transactions, and receive support, enhancing overall satisfaction.

5.Regulatory Compliance: Banking software helps institutions comply with regulatory requirements by enforcing KYC, AML, and other financial regulations.

6.Risk Management: It facilitates risk assessment and monitoring by providing tools for analyzing transaction patterns and identifying potential threats.

7.Reporting and Analysis: Banking software generates detailed reports and analytics, offering insights into financial performance, customer behavior, and market trends.

8.Integration: It integrates with other banking systems and third-party services to streamline operations and improve interoperability.

9.Scalability: Banking software is designed to accommodate growth and changes in the banking environment, ensuring scalability and adaptability.

10.Innovation: It drives innovation in banking services by enabling the introduction of new features such as mobile banking, digital wallets, and AI-driven analytics.

1.3.2 Scope

Expanding the scope of KYC & Account Opening In Credit Co-Operative software involves incorporating additional functionalities and features to meet evolving industry demands and customer expectations. Here are some elements to consider adding:

- **Mobile Banking:** Develop mobile applications to enable customers to access banking services on smartphones and tablets, allowing for convenient account management and transactions on-the-go.
- **Digital Payments:** Integrate support for various digital payment methods such as mobile wallets, contactless payments, and peer-to-peer transfers to offer customers flexible and secure payment options.
- **Personal Finance Management:** Include tools for personal finance management, such as budgeting, expense tracking, and goal setting, to help customers better manage their finances and achieve their financial goals.
- **Advanced Analytics:** Enhance analytical capabilities to provide deeper insights into customer behavior, market trends, and risk factors, enabling banks to make data-driven decisions and improve business performance.
- **Artificial Intelligence and Machine Learning:** Implement AI and ML algorithms to automate processes, enhance fraud detection, personalize customer experiences, and improve predictive analytics for better risk management and customer service.
- **Open Banking APIs:** Develop APIs that enable seamless integration with third-party financial services and applications, allowing customers to access a wider range of banking products and services from different providers.
- **Blockchain Technology:** Explore the integration of blockchain technology to enhance security, transparency, and efficiency in areas such as payments, identity verification, and trade finance.
- **Customer Relation and customer loyalty. ship Management (CRM):** Integrate CRM functionalities to track customer interactions, manage leads, and provide personalized services, fostering stronger relationships.
- **Accessibility and Inclusivity:** Ensure that banking software is accessible to all users, including those with disabilities, by adhering to accessibility standards and providing features such as screen readers and alternative input methods.



CHAPTER-II
SURVEY OF TECHNOLOGY

2.Survey of Technology PHP

PHP (Hypertext Preprocessor) is a widely-used open-source server-side scripting language designed for web development. It is especially suited for creating dynamic and interactive websites, integrating seamlessly with HTML. PHP can be embedded directly into HTML code, and it works efficiently with databases like MySQL. Its ease of use, flexibility, and extensive community support make it a popular choice for web developers.

To Run the simple program of PHP we need is:

Web Server like Apache, Nginx, or IIS to process PHP scripts. Apache is commonly used with PHP in the LAMP (Linux, Apache, MySQL, PHP) stack. PHP Interpreter: The PHP interpreter, which is typically installed as a module or a standalone executable that the web server can call to execute PHP scripts.

Database (Optional): A database server like MySQL, MariaDB, PostgreSQL, etc., if your PHP application requires data storage and retrieval. Operating System: PHP can run on various operating systems, including Linux, Windows, and macOS.

Web Browser: A web browser to access and test the PHP application, though not a strict requirement for running PHP scripts.

What is PHP?

PHP (Hypertext Preprocessor) is a widely-used open-source server-side scripting language designed for web development. It enables the creation of dynamic and interactive web pages by embedding code within HTML. PHP is executed on the server, generating HTML content for the client's browser. It supports numerous databases, with MySQL being the most common, and is a core component of the LAMP stack (Linux, Apache, MySQL, PHP). Its ease of use, flexibility, and extensive community support make it a popular choice for web developers.

What is PHP File?

A PHP file is a text file with a .php extension that contains PHP code, along with HTML, CSS, and JavaScript. When requested by a client, the web server processes the PHP code, executes scripts, and sends the resulting HTML output to the client's browser.

This enables the creation of dynamic, interactive web pages that can interact with databases and handle user input.

Why PHP?

- PHP runs on various platforms (Windows, Linux, Unix, Mac OS X, etc.)
- PHP is compatible with almost all servers used today (Apache, IIS, etc.)
- PHP supports a wide range of databases
- PHP is free. Download it from the official PHP resource: www.php.net
- PHP is easy to learn and runs efficiently on the server side

Basic Syntax Of PHP

PHP Tags: PHP code is embedded within HTML using the `<?php ?>` tags.

```
<?php
```

```
// PHP code goes here
```

```
?>
```

Echo Statement: Used to output text or variables to the web browser. It is commonly used to display dynamic content, such as HTML elements, text messages, or the values of variables.

```
<?php
```

```
echo "Hello, World!";
```

```
?>
```

Variables: Declared using the \$ sign followed by the variable name.

```
<?php
```

```
    $greeting = "Hello, World!";
```

```
    echo $greeting;
```

```
?>
```

variables are used to store and manipulate data. Here are some key points about variables in PHP:

1. **Declaration:** Variables are declared using the dollar sign (\$) followed by the variable name. Variable names are case-sensitive and must start with a letter or underscore.

```
php
```

```
Copy code
```



```
$name = "John";
```

2. **Data Types:** PHP variables are loosely typed, meaning they do not require explicit declaration of data types. Variables can hold various types of data, such as strings, integers, floats, booleans, arrays, objects, and more.

```
php
```

Copy code

```
$age = 30; // integer
```

```
$height = 5.9; // float
```

```
$isStudent = true; // boolean
```

```
$colors = array("red", "green", "blue"); // array
```

3. **Variable Scope:** PHP variables have different scopes, which determine where they can be accessed. The main variable scopes are:

- o **Global:** Variables declared outside of any function have global scope and can be accessed from anywhere in the script.
- o **Local:** Variables declared within a function have local scope and can only be accessed within that function.
- o **Static:** Variables declared with the `static` keyword retain their value between function calls.

```
php
```

Copy code

```
$globalVar = "I am global"; // global variable
```

```
function myFunction() {
```

```
    $localVar = "I am local"; // local variable
```

```
    static $staticVar = 0; // static variable
```

```
    $staticVar++;
```

```
    echo $localVar;
```

```
    echo $staticVar;
```

```
}
```

4. **Variable Naming Conventions:** Variable names should be descriptive and follow certain conventions for readability. Common conventions include using camelCase or snake_case for variable names.

3.Requirement and Analysis:

3.1 Problem Definition

In today's financial landscape, credit co-operatives play a vital role in providing banking services to communities and smaller groups. However, the process of Know Your Customer (KYC) compliance and account opening can be cumbersome, time-consuming, and prone to errors. Therefore, there is a need for a streamlined solution that addresses these challenges while ensuring regulatory compliance and enhancing customer experience. In small towns this software like Credit Co-Operatives are very important because these software are affordable.

For small towns Co-Operative Societies are very important but the budget they have is not that enough that's why a small scale of project is needed.

1. Syntax Errors:

- **Missing Semicolons:** One of the most common PHP errors is missing semicolons at the end of statements.
- **Mismatched Braces:** Incorrectly matching braces `{}` can lead to syntax errors.

2. Undefined Variables:

- Using variables that have not been defined can lead to unexpected behaviors or errors.

3. File Inclusion Errors:

- Incorrect paths in `include` or `require` statements can cause fatal errors.

4. Form Handling Issues:

- Incorrectly handling form data, such as not validating or sanitizing input, can lead to security vulnerabilities like SQL injection or XSS.

Database Issues

1. Connection Problems:

- Incorrect database credentials or configuration settings can prevent the PHP application from connecting to the database.

2. SQL Injection:

- Not properly sanitizing user input can lead to SQL injection attacks, compromising the database's security.

3. Data Integrity Issues:

- o Inconsistent or corrupt data due to lack of constraints (e.g., foreign keys) or proper validation.

4. Performance Issues:

- o Slow queries due to lack of indexing, inefficient SQL statements, or large data volumes.

3.2 Planning and Scheduling

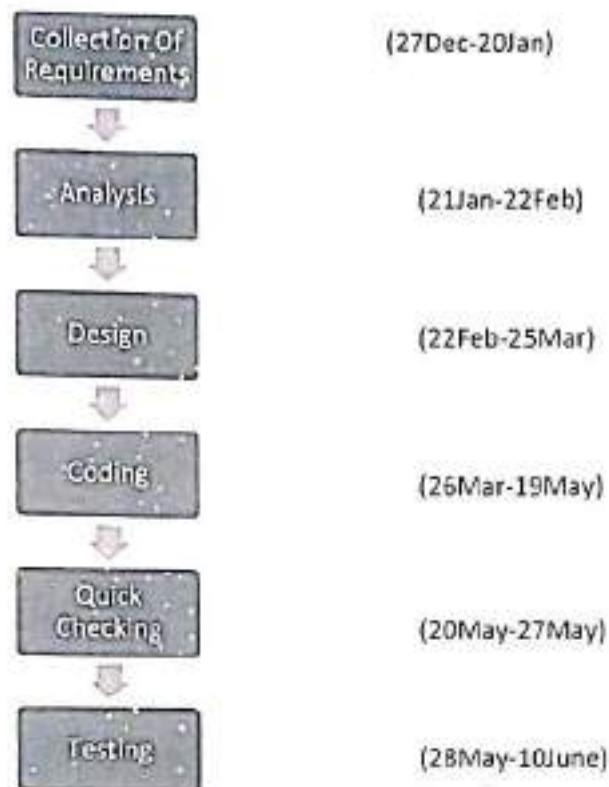

3.3 Software and Hardware Requirement

Ensuring that both software and hardware meet the needs of your PHP website is crucial for its performance, scalability, and security. Regular updates, proper configuration, and adherence to best practices will help in maintaining an efficient and robust web application. The entire software requirement analysis has given the following specification.

5. Implementation and Working

5.1 Screen Shots:-

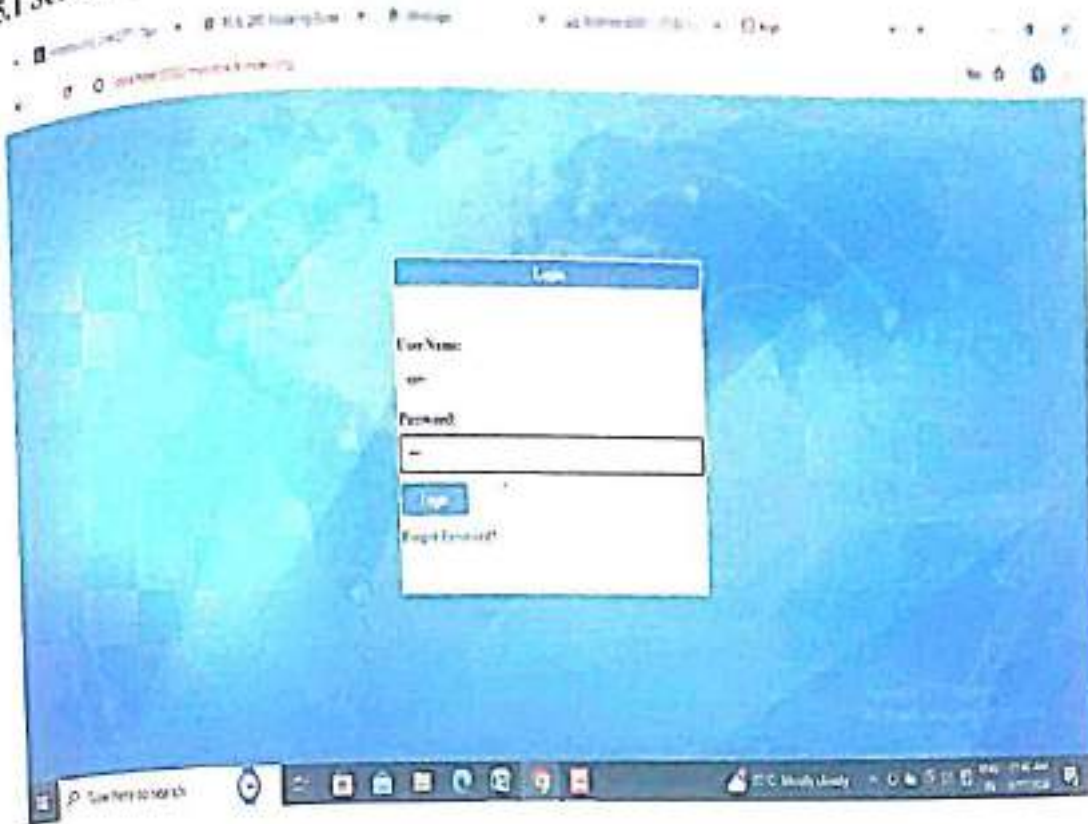

Fig:5.1 Login Page

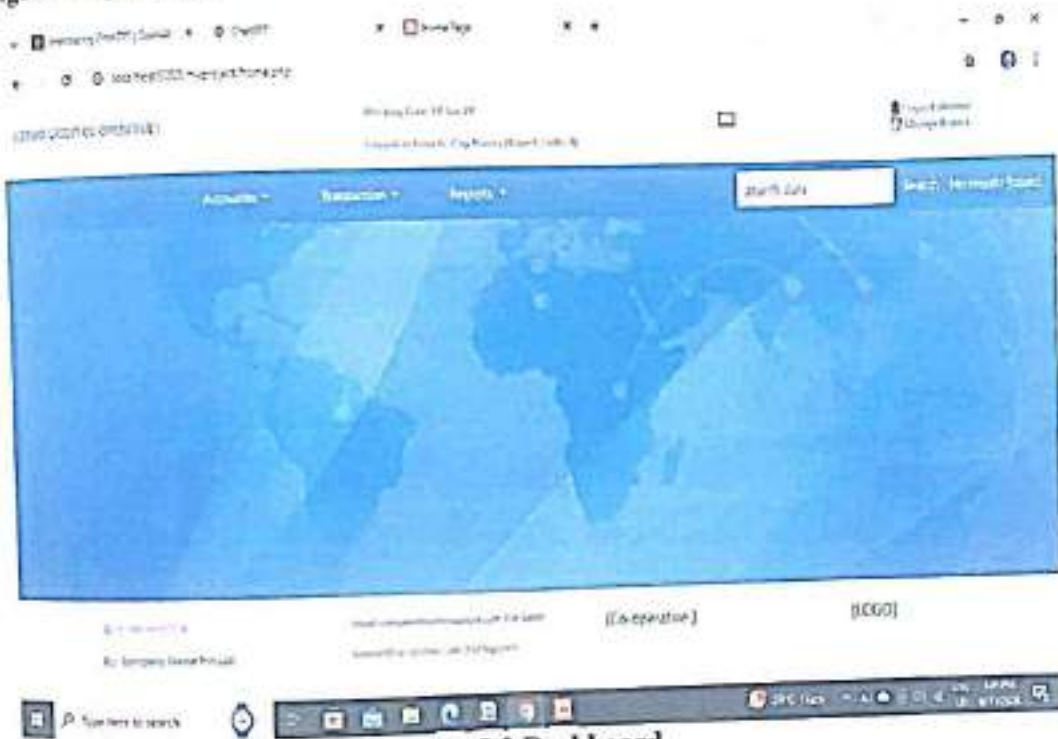

Fig:5.2 Dashboard

KYC And Account Opening In Credit Co-Operative

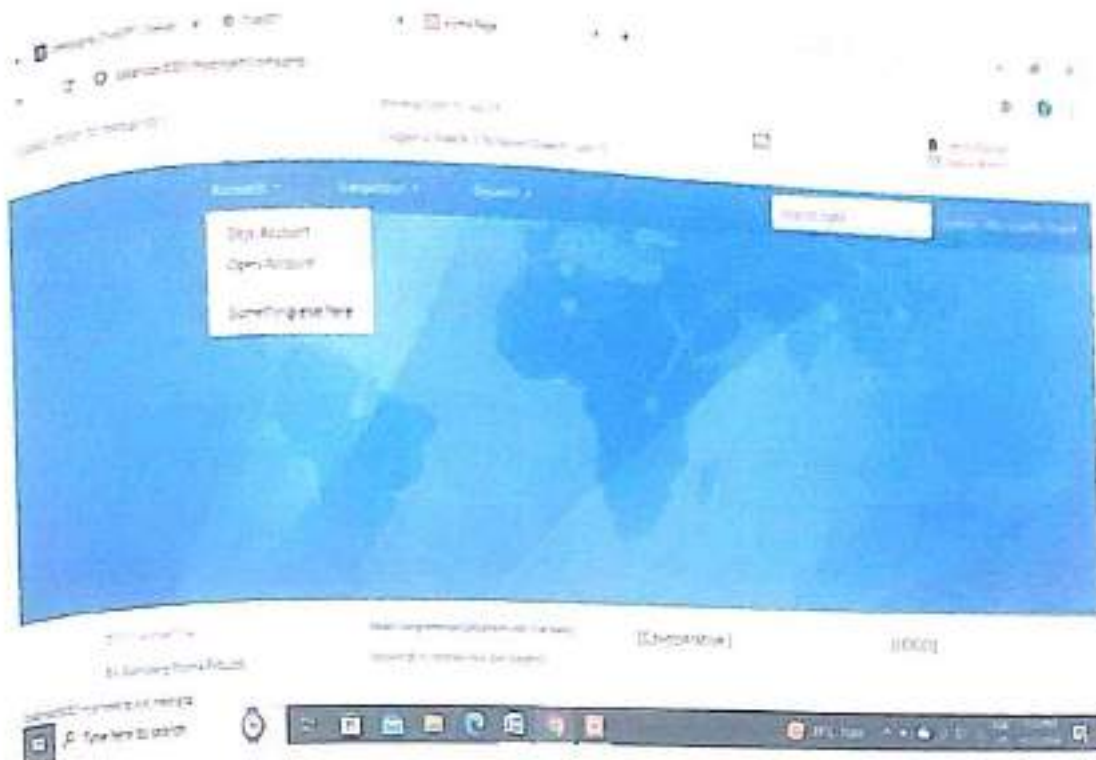

Fig:5.3 Glyce Account

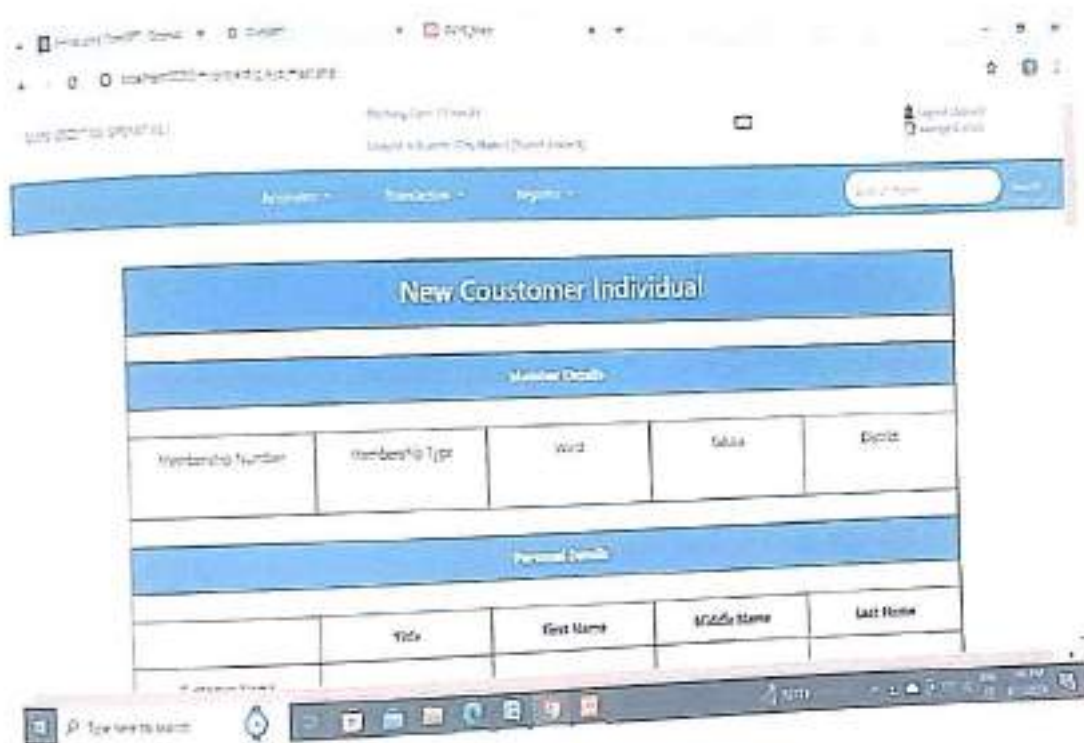

Fig:5.4 Glyce Account

KYC And Account Opening In Credit Co-Operative

Proof of Identity/Address

Check	Document	ID Proof	ADPR Proof	Document No.	Expiry Date (If Any)
1	Pass Card	<input type="checkbox"/>	<input type="checkbox"/>		
2	Banking ID	<input type="checkbox"/>	<input type="checkbox"/>		
3	Councils Letter	<input type="checkbox"/>	<input type="checkbox"/>		

Add Your Details

Correspondence Address

Address: _____

Country: State: District: Sub-District: City:

Area Code: Pin Code:

Contact Details

Telephone No. Office	<input type="text"/>	Telephone No. Residential	<input type="text"/>	Mobile No.	<input type="text"/>
Fax No.	<input type="text"/>	Mail	<input type="text"/>		

Other Details

Income Range	<input type="text"/>	Net Worth	<input type="text"/>	Age	<input type="text"/>
Educational Qualification	<input type="text"/>	Other Educational Qualification	<input type="text"/>	Document Attach	<input type="text"/>
Referral Information	<input type="text"/>	Introducer Category	<input type="text"/>	Ref. Category	<input type="text"/>

Account Type: (Co-operative) (COP)

Fig:5.5 Glyc Account

KYC And Account Opening In Credit Co-Operative

The screenshot displays a web application interface for viewing customer data. At the top, there is a navigation bar with 'Accounts', 'Transaction', and 'Reports' menus. Below this is a search bar. The main content area is titled 'View Customer Individual Data' and contains a table with the following columns: S#, First Name, Last Name, District, Date of Birth, Nationality, Occupation, Email, and Education. There are 9 rows of data, each with a unique S# and corresponding personal details. At the bottom, there is a search bar and a Windows taskbar.

S#	First Name	Last Name	District	Date of Birth	Nationality	Occupation	Email	Education
1	Om	Trusti	Amravati	2001-02-01	Indian	student	amrapath@gmail.com	Graduation
2				1979-05-01	Indian	Self		Not Selected
3	Om	Trusti	Amravati	2001-02-01	Indian	student	amrapath@gmail.com	Post Graduation
4				1970-05-01	Indian	Self		Not Selected
5	Vish	Koti	Chandrapur	1970-05-01	Indian	Self		Not Selected
7			MS	1970-05-01	Indian	Self		Not Selected
9			MS	1970-05-01	Indian	Self		Not Selected

Fig:5.6 Gkyc Account Record (Display)

The screenshot shows the 'Open New Account' form in a web application. The form includes several input fields: 'Account Type' (dropdown menu), 'Parent Account Head' (dropdown menu), 'Scheme' (dropdown menu), 'Account Opening Date' (calendar icon), and 'Member Number' (text input). Below these fields, there are labels for 'By Company Name (MCA21)', 'By Company Name (MCA21)', 'By Company Name (MCA21)', and 'By Company Name (MCA21)'. At the bottom, there are dropdown menus for 'Co-operative' and '10000'. The interface includes a navigation bar, a search bar, and a Windows taskbar.

Fig:5.7 Open Account

KYC And Account Opening In Credit Co-Operative

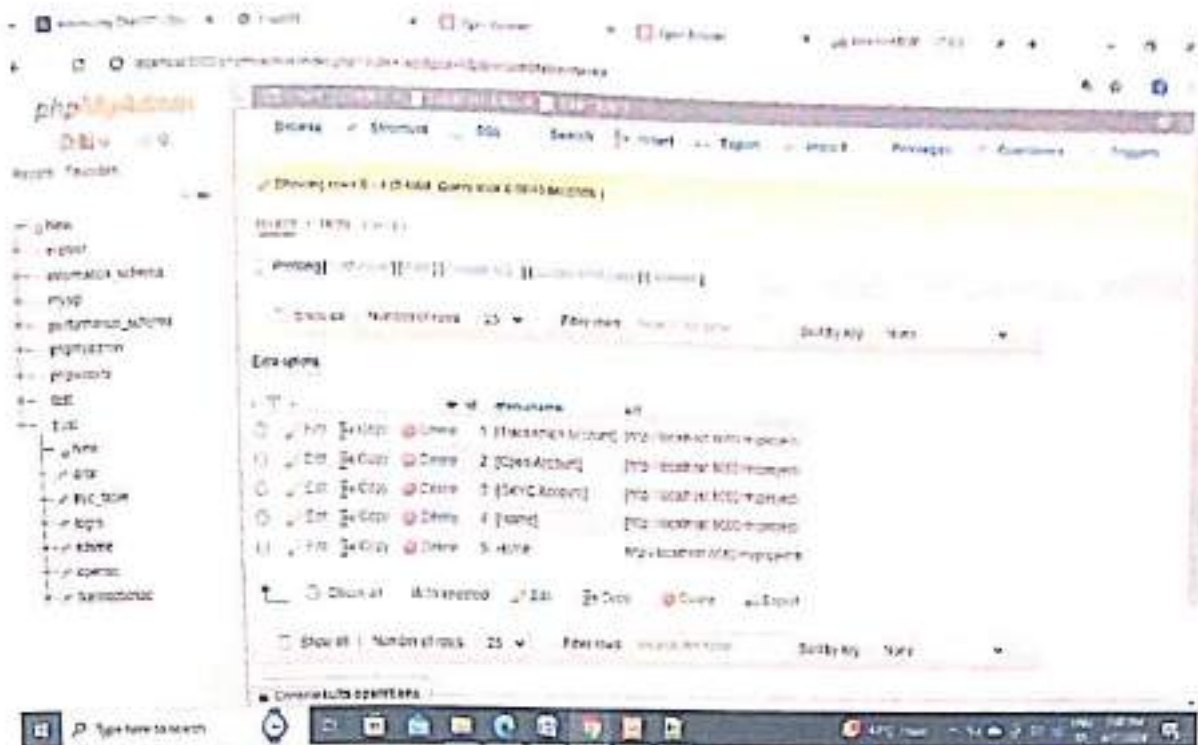

Fig:4 Table of navel for vabar search option

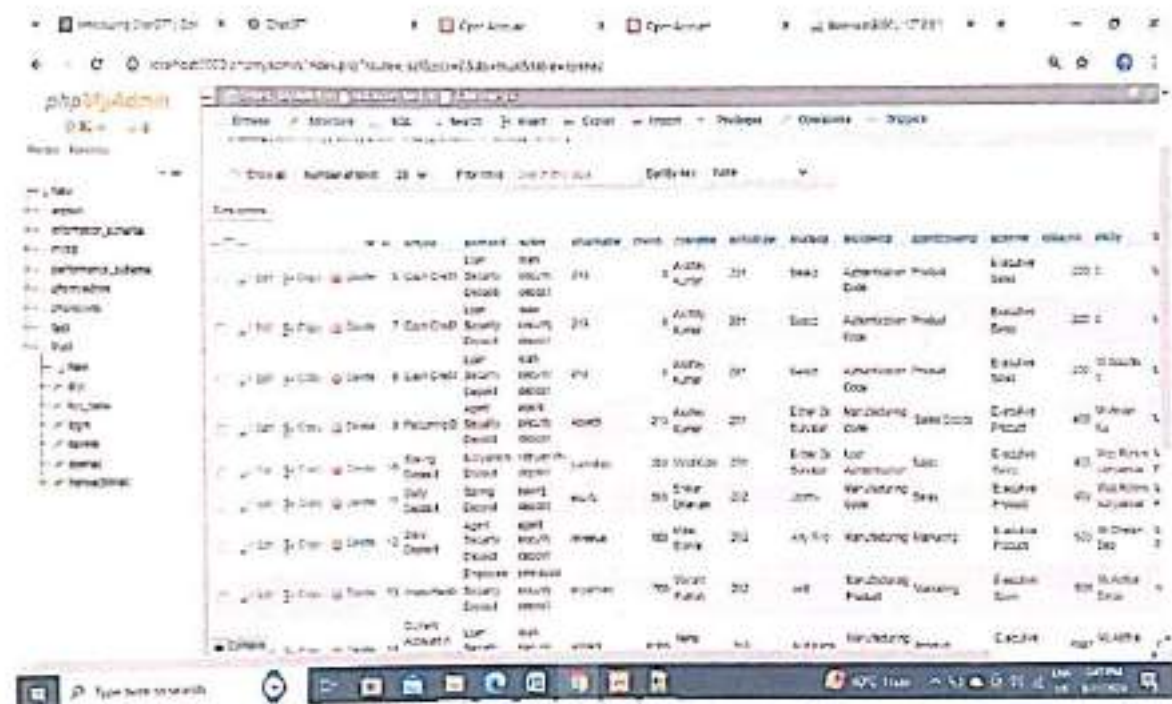

Fig:5 Inserted Data in the open account

6.3 BIBLIOGRAPHY

The KYC and Account Opening process in a credit co-operative involves listing the sources that were consulted or referenced during the project development. Here's an example of how you could structure the bibliography:

Bibliography

1. Smith, John. "Understanding KYC Processes in Financial Institutions." *Journal of Finance and Banking*, vol. 25, no. 2, 2019, pp. 45-62
2. Brown, Sarah. "Best Practices for Account Opening Procedures in Credit Co-operatives." *Credit Union Management*, vol. 15, no. 4, 2020, pp. 78-89.
3. PHP Manual. "PHP Documentation." PHP.net, www.php.net/manual/en/. Accessed 10 May 2024.
4. W3Schools. "PHP Tutorial." W3Schools, www.w3schools.com/php/. Accessed 12 May 2024.
5. MySQL Documentation. "MySQL Reference Manual." MySQL.com, dev.mysql.com/doc/. Accessed 15 May 2024.
6. Garcia, Maria. "Building Secure Web Applications with PHP and MySQL." O'Reilly Media, 2023.
7. Rahman, Tariq. "Mastering PHP Design Patterns." Packt Publishing, 2022.
8. Credit Co-operative Regulations Act, 2020. [Online]. Available: www.regulations.gov/credit-cooperative-act. Accessed 20 May 2024.
9. Financial Action Task Force (FATF). "Guidance on Anti-Money Laundering and Counter-Terrorist Financing Measures." FATF, www.fatf-gafi.org/publications/. Accessed 25 May 2024.
10. International Organization for Standardization (ISO). "ISO 27001: Information Security Management Systems." ISO, www.iso.org/standard/62274.html. Accessed 28 May 2024.

Ensure to format the bibliography entries according to the citation style required by your institution or publisher. This example uses the APA style format.

REFERENCES

- ❖ *"PHP and MySQL Web Development" by Luke Welling and Laura Thomson*
- ❖ *"Learning PHP, MySQL & JavaScript" by Robin Nixon*
- ❖ *"PHP Solutions: Dynamic Web Design Made Easy" by David Powers*
- ❖ *"MySQL Explained: Your Step-by-Step Guide" by Andrew Comeau and Stephen BurgeHP*
- ❖ *Manual: Official PHP documentation available at php.net/manual/en/*
- ❖ *MySQL Documentation: Official MySQL documentation available at dev.mysql.com/doc/*

SSESA's Science College, Congress Nagar, Nagpur
Department of Computer Science
Project Topic List

M. C.A-II (Sem-IV)

Session-2023-24

SR NO.	NAME OF THE STUDENT	NAME OF THE PROJECT TITLE	GUIDE NAME
1	Chinmaybhake	Hospital site	Dr.J.K.Keche
2	Iqrasabri	Design agency website	Dr.M.T.Wanjari
3	Divyapawar	Design agency website	Dr.M.T.Wanjari
4	Swati jamgade	Design agency website	Dr.M.T.Wanjari
5	Vidhisoneji	Metadata software institute website	MS.Asfiya Sheikh
6	Punamgotmare	Dawabag application	MS.Asfiya Sheikh
7	Ankitawaghare	Dawabag application	MS.Asfiya Sheikh
8	Yewatikinkar	Dawabag application	MS.Asfiya Sheikh
9	Madhavkarkare	Intrusion detection system	Dr.S.R.Gedam
10	Simrankaurbedi	Infivent	Dr.M.T.Wanjari
11	Aditya bansule	Syntax level up software organisation website	Dr.J.K.Keche
12	Sahilasutkar	Syntax level up software organisation website	Dr.J.K.Keche
13	Pradhumncharde	English sentences voice detection and conversion for a website	Mr. A. A. Bodkhe
14	Tejasthakare	Online learning portal	Dr.A.A.Halder
15	Yashashreelangde	Perpetual invention application	Mr. A. A. Bodkhe
16	Aachalchurhe	Perpetual invention application	Mr. A. A. Bodkhe
17	Pranaygatfane	E-classroom webtech	Dr.S.R.Gedam
18	Sonalulabhaje	E-classroom webtech	Dr.S.R.Gedam



19	Rajsidattakingri	Kyc and account opening credit co-operative	Dr.M.T.Wanjari
20	Payalpaunikar	Dashboard Webtech	Dr.V.C.Pande
21	Rutujakalbande	Evens-E waste management website	Dr.A.A.Halder
22	Bhagyashrimahulkar	Evens-E waste management website	Dr.A.A.Halder
23	Ashwini surkar	Toll Plaza Mangement Software	Ms.P.M.Dadhe
24	Mitalibonde	Eye Disease Prediction Website	Mr. A. A. Bodkhe
25	Ketanmendhule	Dandeli Adventure Camp Web Application	Dr.P.M.Dadhe
26	Ritikawankar	Toll Plaza Mangement Software	Dr.P.M.Dadhe
27	Sagaryedaskar	Dandeli Adventure Camp Web Application	MS.Asfiya Sheikh
28	Sufiyan kureshi	Customer Relationship Management	Dr.V.C.Pande
29	TanmayAmbulkar	Food Truck Website	Dr.V.C.Pande
30	Vedankitamohod	Eye Disease Prediction Website	Mr. A. A. Bodkhe



Head

Department of the Computer Science

Professor & Head
Department of Computer Science
S.S.S. Am's Science College
Congress Nagar Nagpur

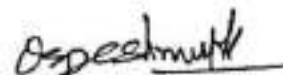

Dr A A Halder
Coordinator, IQAC
Science College,
Congress Nagar, Nagpur

Dr. O. S. Deshmukh
Principal
Science College,
Congress Nagar, Nagpur